

2360 Boswell Road
Chula Vista, CA 91914
Phone 619.216.1444
Fax 619.216.1474
E-Mail tech@explorerprocomp.com



EXPLORER COMPETITION PRODUCTS

Suspension Systems that Work!

**21400,22000,24020,24500 &
24600
Light Bar Kit
Socket-Socket Style**

This document contains very important information that includes warranty information and instructions for resolving problems you may encounter. Please keep it in the vehicle as a permanent record.

- ◆ This installation requires a professional mechanic!
- ◆ We recommend that you have access to a Ford/GM service manual for your vehicle to assist in the disassembly and reassembly of your vehicle. It contains a wealth of detailed information.
- ◆ Prior to installation, carefully inspect the vehicle's steering and driveline systems paying close attention to the tie rod ends, ball joints, wheel bearing preload, pitman and idler arm. Additionally, check steering-to-frame and suspension-to-frame attaching points for stress cracks. The overall vehicle must be in excellent working condition. Repair or replace all worn or damaged parts!
- ◆ Read the instructions carefully and study the illustrations before attempting installation! You may save yourself a lot of extra work.
- ◆ Check the parts and hardware against the parts list to assure that your kit is complete. Separating parts according to the areas where they will be used and placing the hardware with the brackets before you begin will save installation time.
- ◆ Check the special equipment list and ensure the availability of these tools.
- ◆ Secure and properly block vehicle prior to beginning installation.
- ◆ ALWAYS wear safety glasses when using power tools or working under the vehicle!
- ◆ Use caution when cutting is required under the vehicle. The factory undercoating is flammable. Take appropriate precautions. Have a fire extinguisher close at hand.
- ◆ Foot pound torque readings are listed on the Torque Specifications chart at the end of the instructions. These are to be used unless specifically directed otherwise. Apply thread lock-retaining compound where specified.
- ◆ *Please note that while every effort is made to ensure that the installation of your Pro Comp lift kit is a positive experience, variations in construction and assembly in the vehicle manufacturing process will virtually ensure that some parts may seem difficult to install. Additionally, the current trend in manufacturing of vehicles results in a frame that is highly flexible and may shift slightly on disassembly prior to installation. The use of pry bars and tapered punches for alignment is considered normal and usually does not indicate a faulty product. However, if you are uncertain about some aspect of the installation process, please feel free to call our tech support department at the number listed on the cover page. We do not recommend that you modify the Pro Comp parts in any way as this will void any warranty expressed or implied by the Explorer Competition Products company.*

Parts

Part #	Description	Quantity	Illustration
90-6207	HARDWARE PACK, LIGHT BAR	1	
70-0501501800	1/2" X 1 1/2" GRADE 8 HEX BOLT	2	
73-05000034	1/2" SAE GRADE 8 FLAT WASHER	4	
72-05000100816	1/2" TOP LOCK NUT	2	
70-0432501504	7/16" X 2 1/2" GRADE 5 CARRIAGE BOLT	2	
72-043100510	7/16" HEXNUT	2	
73-04300036	7/16" SPLIT-LOCK WASHER	2	
90-6211	SPACER PARTS PACK	1	
15-11213	PLASTIC PLUGS	2	

LIGHTBARS ARE APPLICATION SPECIFIC. REFER TO THE CHART ON PAGE 2 FOR YOUR CORRECT LIGHTBAR PART NUMBER.

Installation

- Carefully check the contents of your Pro-Comp light bar against the above parts list to ensure all parts are available.
- To prevent cosmetic damage to the finish of your OEM bumper, it is a good idea to temporarily cover the areas to be drilled with duct tape to protect the surface.
- Set the light bar in position on your bumper to locate the mount holes. When the light bar is correctly positioned, all four sockets will be flush to the surface of the bumper and the upper sockets will be centered on the upper surface of your bumper. Mark the upper mount holes first.
- Set the light bar aside, center punch the previously marked holes and drill through with a 7/16" bit.
- Install the supplied **7/16" X 2 1/2"** carriage bolts through the sockets as shown in illustration 1, and install the 7/16" lock washers and nuts. Snug up this hardware but do not fully tighten at this point.
- Make sure the ends of the bar are parallel to the surface of the bumper. Mark the location of the front lower holes using the light bar as a guide.
- Remove the light bar from the vehicle. Center punch the previously marked holes and drill through with a 7/16" bit.
- Reinstall the light bar using the carriage bolts through the top and the **1/2" X 1 1/2"** bolts through the front. Tighten all hardware to specifications
- Install the socket plugs (**PN 15-11213**).
- You are now ready to install your Explorer Pro Comp lights. Numerous models of high quality lights are sold by Explorer Pro Comp. Contact your local sales representative for additional details!

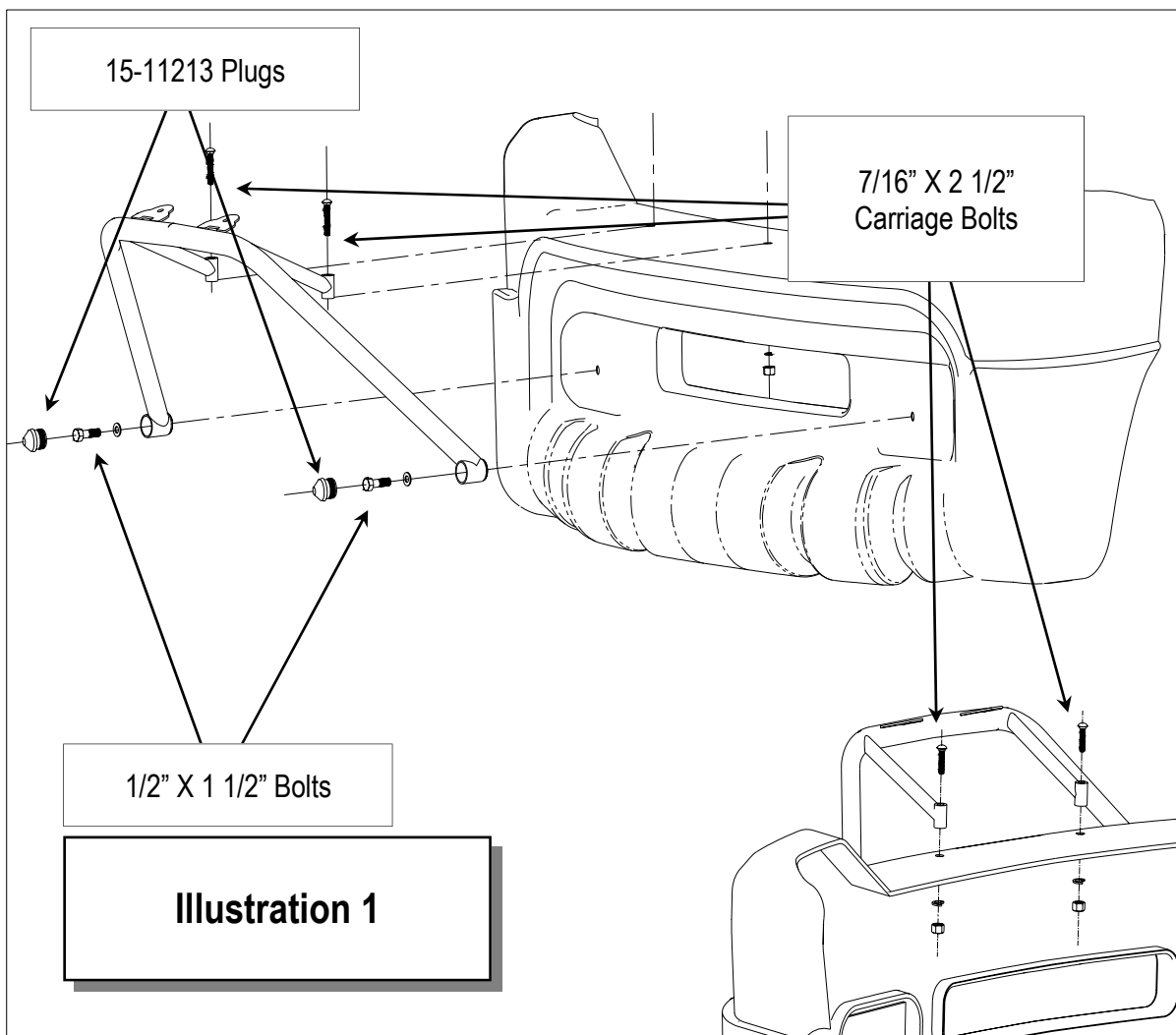

MAKE	YEAR	MODEL	KIT NO.	LIGHT-BAR PART NO.
GMC	1988-89	C1500 2WD	21400	90-2262
DODGE	2000	RAM 1500 V8 MAGNUM 2WD	22000	90-2291
FORD	1997	F-150 2WD	24020	90-2265
FORD	1997	F-150 XL EXTRA CAB 2WD	24500	90-2295
FORD	2000	F-150 TRITON 4-DOOR	24600	90-2299

Use this only as a guide for hardware without a called out torque specification in the instruction manual.

Bolt Torque and ID						
Decimal System			Metric System			
All Torques in Ft. Lbs. Maximums						
Bolt Size	Grade 5	Grade 8	Bolt Size	Class 9.8	Class 10.9	Class 12.9
5/16	15	20	M6	5	9	12
3/8	30	45	M8	18	23	27
7/16	45	60	M10	32	45	50
1/2	65	90	M12	55	75	90
9/16	95	130	M14	85	120	145
5/8	135	175	M16	130	165	210
3/4	185	280	M18	170	240	290

1/2-13x1.75 HHCS Grade 5 Grade 8
(No. of Marks + 2)

D T L X

G = Grade (Bolt Strength)
D = Nominal Diameter (Inches)
T = Thread Count (Threads per Inch)
L = Length (Inches)
X = Description (Hex Head Cap Screw)

M12-1.25x50 HHCS

D T L X

P = Property Class (Bolt Strength)
D = Nominal Diameter (Millimeters)
T = Thread Pitch (Thread Width, mm)
L = Length (Millimeters)
X = Description (Hex Head Cap Screw)

Notice to Owner operator, Dealer and Installer:

Vehicles that have been enhanced for off-road performance often have unique handling characteristics due to the higher center of gravity and larger tires. This vehicle may handle, react and stop differently than many passenger cars or unmodified vehicles, both on and off-road. You must drive your vehicle safely! Extreme care should always be taken to prevent vehicle rollover or loss of control, which can result in serious injury or even death. Always avoid sudden sharp turns or abrupt maneuvers and allow more time and distance for braking! Pro Comp reminds you to fasten your seat belts at all times and reduce speed! We will gladly answer any questions concerning the design, function, maintenance and correct use of our products.

Please make sure your Dealer/Installer explains and delivers all warning notices, warranty forms and instruction sheets included with Pro Comp product.

Application listings in this catalog have been carefully fit checked for each model and year denoted. However, Pro Comp reserves the right to update as necessary, without notice, and will not be held responsible for misprints, changes or variations made by vehicle manufacturers. Please call when in question regarding new model year, vehicles not listed by specific body or chassis styles or vehicles not originally distributed in the USA.

Please note that certain mechanical aspects of any suspension lift product may accelerate ordinary wear of original equipment components. Further, installation of certain Pro Comp products may void the vehicle's factory warranty as it pertains to certain covered parts; it is the consumer's responsibility to check with their local dealer for warranty coverage before installation of the lift.

Warranty and Return policy:

Pro Comp warrants its full line of products to be free from defects in workmanship and materials. Pro Comp's obligation under this warranty is limited to repair or replacement, at Pro Comp's option, of the defective product. Any and all costs of removal, installation, freight or incidental or consequential damages are expressly excluded from this warranty. Pro Comp is not responsible for damages and / or warranty of other vehicle parts related or non-related to the installation of Pro Comp product. A consumer who makes the decision to modify his vehicle with aftermarket components of any kind will assume all risk and responsibility for potential damages incurred as a result of their chosen modifications. Warranty coverage does not include consumer opinions regarding ride comfort, fitment and design. Warranty claims can be made directly with Pro Comp or at any factory authorized Pro Comp dealer.

IMPORTANT! To validate the warranty on this purchase please be sure to mail in the warranty card.

Claims not covered under warranty-

- Parts subject to normal wear, this includes bushings, bump stops, ball joints, tie rod ends and heim joints
 - Discontinued products at Pro Comp's discretion
- Bent or dented product
- Finish after 90 days
- Leaf or coil springs used without proper bump stops
- Light bulbs
- Products with evident damage caused by abrasion or contact with other items
- Damage caused as a result of not following recommendations or requirements called out in the installation manuals
- Products used in applications other than listed in Pro Comp's catalog
- Components or accessories used in conjunction with other manufacturer's systems
- Tire & Wheel Warranty as per Pro Competition Tire Company policy
- Warranty claims without "Proof of Purchase"
- Pro Comp Pro Runner coil over shocks are considered a serviceable shock with a one-year warranty against leakage only. Rebuild service and replacement parts will be available and sold separately by Pro Comp. Contact Pro Comp for specific service charges.
- Pro Comp accepts no responsibility for any altered product, improper installation, lack of or improper maintenance, or improper use of our products.

E-Mail: tech@explorerprocomp.com
Website: www.explorerprocomp.com
Fax: (619) 216-1474
Ph: (619) 216-1444

PLACE
WARRANTY REGISTRATION
NUMBER
HERE: _____