

2360 Boswell Road
Chula Vista, CA 91914
Phone 619.216.1444
Fax 619.216.1474
E-Mail tech@explorerprocomp.com



PRO COMP SUSPENSION

Suspension Systems that Work!

**Part #25000
2005-2006
Toyota Tacoma
4WD & 2WD Pre
Runner Light
Bar Kit**

This document contains very important information that includes warranty information and instructions for resolving problems you may encounter. Please keep it in the vehicle as a permanent record.

Parts List:

Part #	Description	Qty.	Illus.	Page
92-2620	LIGHT BAR	1	3,4,5	5,6
90-3643	LOWER MOUNTING BRACKET	2	1,2,3	4,5
90-3646	DRVR. UPPER SUPPORT BRACKET	1	2,5	4,6
90-3647	PASS. UPPER SUPPORT BRACKET	1	-	-
90-6500	HARDWARE PACK: Light Bar	1	-	-
70-0374001806	3/8" X 4" ALLEN HEAD BOLT	4	2	4
70-371501806	3/8" X 1 1/2" ALLEN HEAD BOLT	2	5	6
73-03700830	3/8" FLAT WASHER	10	2,5	4,6
72-037100812	3/8" NYLOCK NUTS	6	2,5	4,6
72-050100812	1/2" NYLOCK NUT PLATED	2	3	5
73-05000830	1/2" SAE WASHER	2	3	5
90-2014	1/4" SPACER	4	2	4

This item is designed as a decorative accessory item. It is not designed as a replacement bumper. It is not intended to provide additional vehicle safety or protection.

BEFORE YOU BEGIN:

- Read instructions and study the illustrations before attempting installation. Separate parts according to the areas where they will be used. Placing the hardware with the brackets before you begin will save installation time.
- Check the parts and hardware against the parts list to assure that your kit is
- Always wear safety glasses when using power tools.

BEFORE YOU BEGIN:

- ◆ **This installation requires a professional mechanic!**
- ◆ We recommend that you have access to a factory service manual for your vehicle to assist in the disassembly and reassembly of your vehicle. It contains a wealth of detailed information.
- ◆ Prior to installation, carefully inspect the vehicle's steering and driveline systems paying close attention to the tie rod ends, ball joints, wheel bearing preload, pitman and idler arm. Additionally, check steering-to-frame and suspension-to-frame attaching points for stress cracks. The overall vehicle must be in excellent working condition. Repair or replace all worn or damaged parts!
- ◆ Read the instructions carefully and study the illustrations before attempting installation! You may save yourself a lot of extra work.
- ◆ Check the parts and hardware against the parts list to assure that your kit is complete. Separating parts according to the areas where they will be used and placing the hardware with the brackets before you begin will save installation time.
- ◆ Check the special equipment list and ensure the availability of these tools.
- ◆ Secure and properly block vehicle prior to beginning installation.
- ◆ ***ALWAYS*** wear safety glasses when using power tools or working under the vehicle!
- ◆ Use caution when cutting is required under the vehicle. The factory undercoating is flammable. Take appropriate precautions. **Have a fire extinguisher close at hand.**
- ◆ Foot pound torque readings are listed on the Torque Specifications chart at the end of the instructions. These are to be used unless specifically directed otherwise. Apply thread lock retaining compound where specified.
- ◆ *Please note that while every effort is made to ensure that the installation of your Pro Comp lift kit is a positive experience, variations in construction and assembly in the vehicle manufacturing process will virtually ensure that some parts may seem difficult to install. Additionally, the current trend in manufacturing of vehicles results in a frame that is highly flexible and may shift slightly on disassembly prior to installation. The use of pry bars and tapered punches for alignment is considered normal and usually does not indicate a faulty product. However, if you are uncertain about some aspect of the installation process, please feel free to call our tech support department at the number listed on the cover page. We do not recommend that you modify the Pro Comp parts in any way as this will void any warranty expressed or implied by the Pro Comp Suspension company.*

Optional Equipment Available from your Pro Comp Distributor!

Traction Bars: 72500B

Mounting kit: 72083B

Skid Plate: 57196

CV Style Driveshaft: 57098

Add-A-Leaf Kit: 13129

Coil Over Upgrade Kit: ,57097MX

Also, Check out our outstanding selection of Pro Comp tires to compliment your new installation!

INSTALLATION INSTRUCTIONS:

1. Position your vehicle on a smooth, flat, hard surface (i.e. concrete or asphalt). Block the rear tires and set the emergency brake.
2. Place the lower mounting bracket (**90-3643**) onto the aluminum frame horn and slide the bracket all the way back until the stops contact the frame horn mount. See ILLUSTRATION 1.
3. Using the lower mounting brackets as a guide, mark and center punch the (4), inner and outer, holes for drilling. See ILLUSTRATION 1.
4. Drill the (4) previously applied marks on the aluminum bumper horn using a **13/32"** drill bit. See ILLUSTRATION 1.
5. Bolt the upper support brace (**90-3646** *drv* and **90-3647** *pass*) to the outside of the lower mounting bracket using the sup-

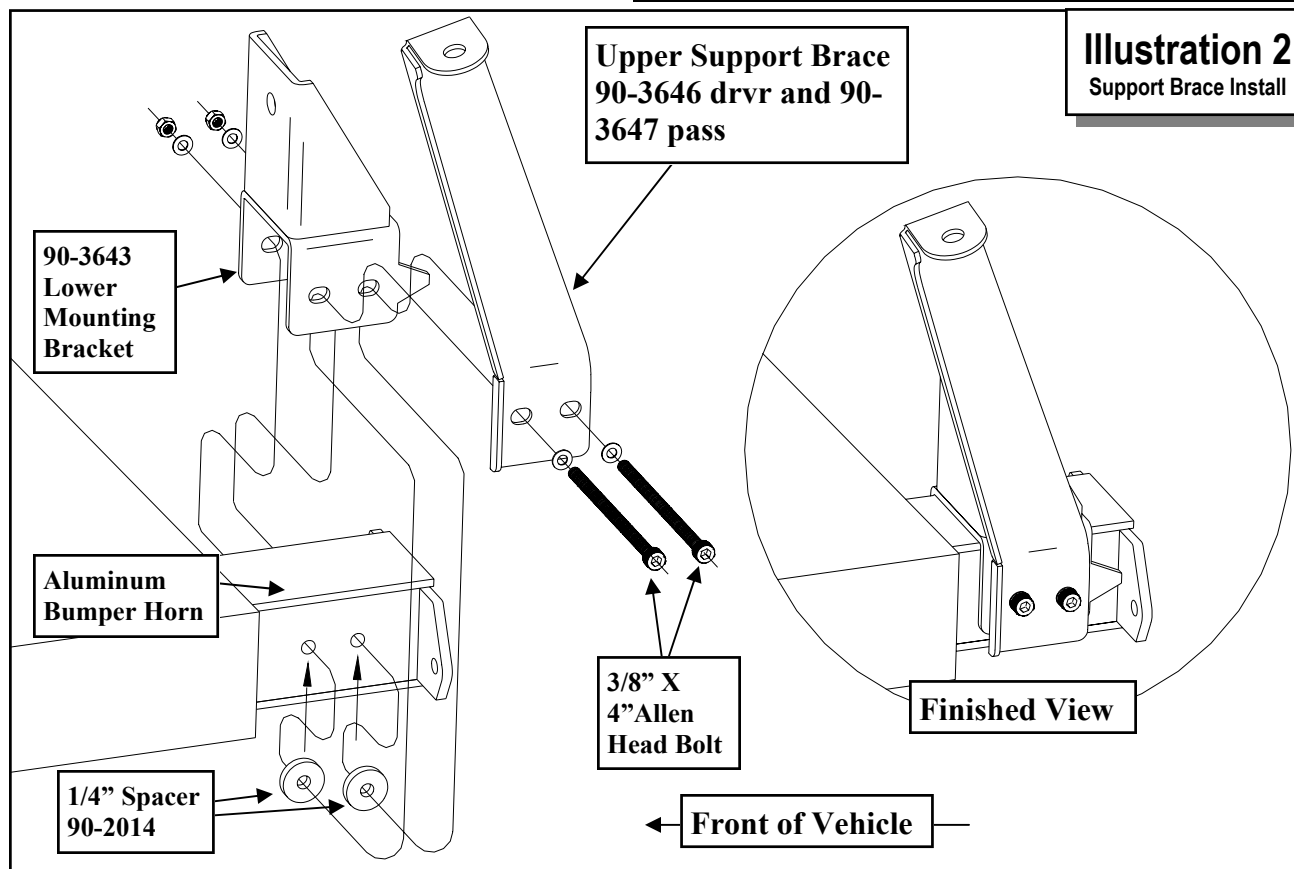
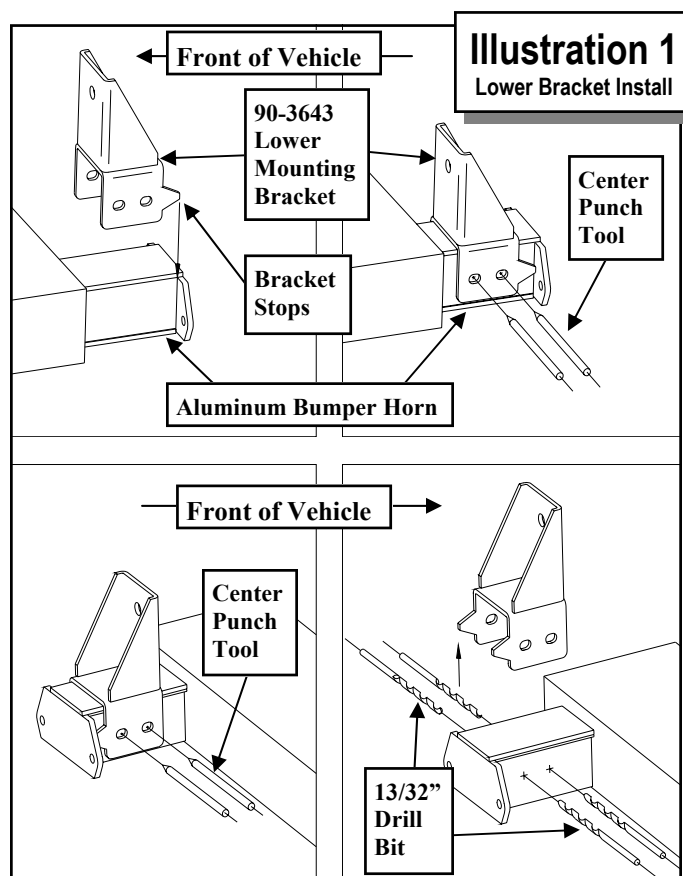

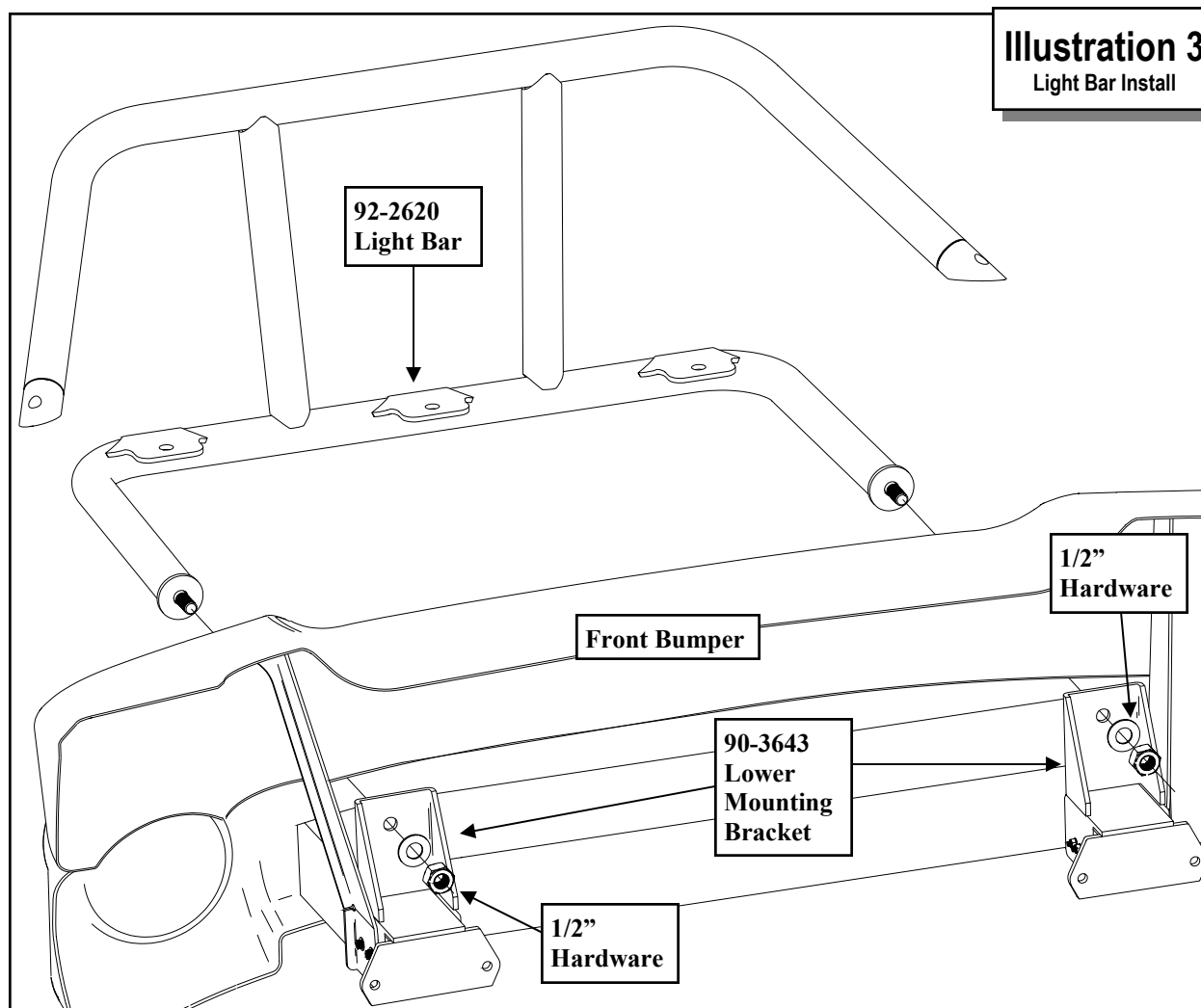

plied 3/8" X 4" Allen head bolt and 1/4" spacers (90-2014 *on the outside of the frame horn only*). See ILLUSTRATION 2. Leave all hardware loose at this time.

NOTE: *The bends of the upper support brace (90-3646 *drvr* and 90-3647 *pass*) will face toward the front and outside of the vehicle.*

NOTE: *Insert the 3/8" X 4" bolt from the outside of the vehicle.*

6. Repeat steps 2 through 5 on the remaining side of the vehicle.

NOTE: *Assistance with steps 7 through 9 will aid in the proper installation of the light bar.*

7. Carefully raise the light bar (92-2620)

into position and guide the lower studs on the light bar into the mounting holes on the lower mounting brackets (90-3643). Secure using the provided 1/2" hardware, but do not tighten at this time. See ILLUSTRATION 3.

8. Center the light bar on the front bumper of the truck. Use the upper holes in the light bar as a guide and mark the bumper for drilling. See ILLUSTRATION 4.
9. Center punch and drill the previously made marks on the top of the bumper using a 13/32" drill bit. See ILLUSTRATION 4.
10. Line the upper support braces (90-3646 *drvr* and 90-3647 *pass*) with the newly

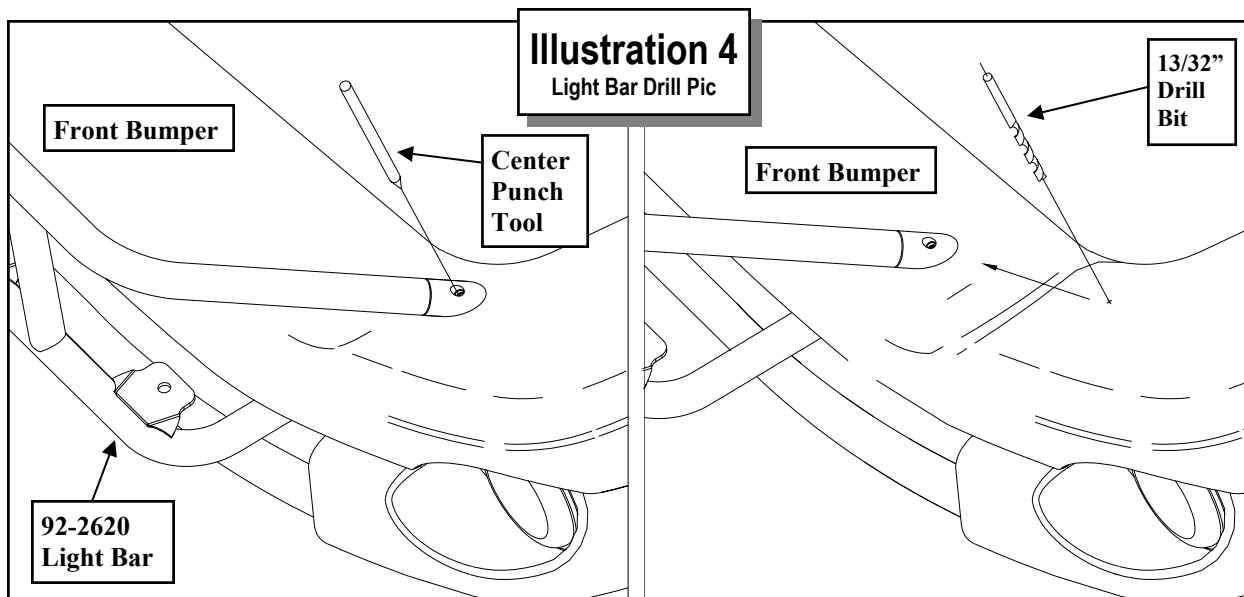

drilled holes in the bumper. Secure using the 3/8" X 1 1/2" Allen head bolt and hardware. See ILLUSTRATION 5.

11. Tighten and torque all the light bar hardware according to the torque chart on page 7 at this time.
12. Install the lights (*Purchased Separately*) to the bar at this time using the instructions and hardware provided with the lights.

NOTES:

- ⇒ After 100 miles recheck for proper torque on all newly installed hardware.
- ⇒ Recheck all hardware for tightness after off road use.

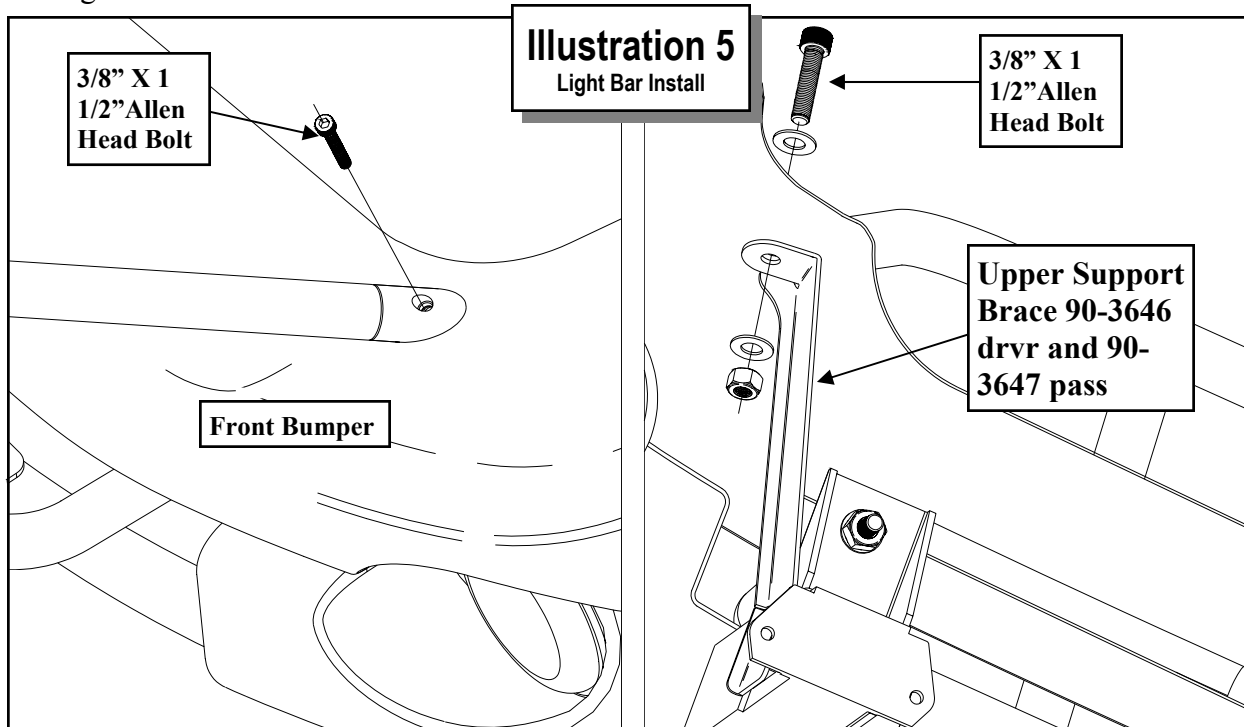

Use this only as a guide for hardware without a called out torque specification in the instruction manual.

Bolt Torque and ID						
Decimal System			Metric System			
All Torques in Ft. Lbs. Maximums						
Bolt Size	Grade 5	Grade 8	Bolt Size	Class 9.8	Class 10.9	Class 12.9
5/16	15	20	M6	5	9	12
3/8	30	45	M8	18	23	27
7/16	45	60	M10	32	45	50
1/2	65	90	M12	55	75	90
9/16	95	130	M14	85	120	145
5/8	135	175	M16	130	165	210
3/4	185	280	M18	170	240	290

1/2-13x1.75 HHCS **Grade 5 Grade 8**
(No. of Marks+2)

D T L X

G = Grade (Bolt Strength)
D = Nominal Diameter (Inches)
T = Thread Count (Threads per Inch)
L = Length (Inches)
X = Description (Hex Head Cap Screw)

M12-1.25x50 HHCS

D T L X

P = Property Class (Bolt Strength)
D = Nominal Diameter (Millimeters)
T = Thread Pitch (Thread Width, mm)
L = Length (Millimeters)
X = Description (Hex Head Cap Screw)

Notice to Owner operator, Dealer and Installer:

Vehicles that have been enhanced for off-road performance often have unique handling characteristics due to the higher center of gravity and larger tires. This vehicle may handle, react and stop differently than many passenger cars or unmodified vehicles, both on and off-road. You must drive your vehicle safely! Extreme care should always be taken to prevent vehicle rollover or loss of control, which can result in serious injury or even death. Always avoid sudden sharp turns or abrupt maneuvers and allow more time and distance for braking! Pro Comp reminds you to fasten your seat belts at all times and reduce speed! We will gladly answer any questions concerning the design, function, maintenance and correct use of our products.

Please make sure your Dealer/Installer explains and delivers all warning notices, warranty forms and instruction sheets included with Pro Comp product.

Application listings in this catalog have been carefully fit checked for each model and year denoted. However, Pro Comp reserves the right to update as necessary, without notice, and will not be held responsible for misprints, changes or variations made by vehicle manufacturers. Please call when in question regarding new model year, vehicles not listed by specific body or chassis styles or vehicles not originally distributed in the USA.

Please note that certain mechanical aspects of any suspension lift product may accelerate ordinary wear of original equipment components. Further, installation of certain Pro Comp products may void the vehicle's factory warranty as it pertains to certain covered parts; it is the consumer's responsibility to check with their local dealer for warranty coverage before installation of the lift.

Warranty and Return policy:

Pro Comp warrants its full line of products to be free from defects in workmanship and materials. Pro Comp's obligation under this warranty is limited to repair or replacement, at Pro Comp's option, of the defective product. Any and all costs of removal, installation, freight or incidental or consequential damages are expressly excluded from this warranty. Pro Comp is not responsible for damages and / or warranty of other vehicle parts related or non-related to the installation of Pro Comp product. A consumer who makes the decision to modify his vehicle with aftermarket components of any kind will assume all risk and responsibility for potential damages incurred as a result of their chosen modifications. Warranty coverage does not include consumer opinions regarding ride comfort, fitment and design. Warranty claims can be made directly with Pro Comp or at any factory authorized Pro Comp dealer.

IMPORTANT! To validate the warranty on this purchase please be sure to mail in the warranty card.

Claims not covered under warranty-

- Parts subject to normal wear, this includes bushings, bump stops, ball joints, tie rod ends and heim joints
 - Discontinued products at Pro Comp's discretion
- Bent or dented product
- Finish after 90 days
- Leaf or coil springs used without proper bump stops
- Light bulbs
- Products with evident damage caused by abrasion or contact with other items
- Damage caused as a result of not following recommendations or requirements called out in the installation manuals
- Products used in applications other than listed in Pro Comp's catalog
- Components or accessories used in conjunction with other manufacturer's systems
- Tire & Wheel Warranty as per Pro Competition Tire Company policy
- Warranty claims without "Proof of Purchase"
- Pro Comp Pro Runner coil over shocks are considered a serviceable shock with a one-year warranty against leakage only. Rebuild service and replacement parts will be available and sold separately by Pro Comp. Contact Pro Comp for specific service charges.
- Pro Comp accepts no responsibility for any altered product, improper installation, lack of or improper maintenance, or improper use of our products.

E-Mail: tech@explorerprocomp.com
Website: www.explorerprocomp.com
Fax: (619) 216-1474
Ph: (619) 216-1444

PLACE
WARRANTY REGISTRATION
NUMBER
HERE: _____