



INSTALLATION INSTRUCTIONS
Rear Bumper Part No. 22400, 23400, 25400, 27400
Fits 1976-2002 Jeep CJ, Wrangler YJ/TJ

HARDWARE KIT 950301

BRACKET KIT 93003

- | | | |
|--------------------------|---------------------------|-------------------------------------|
| 8 EA. 7/16 x 1-1/2 bolts | 4 EA. 1/2" x 1-1/2" bolts | 2 EA. mounting brackets (Bkt # 003) |
| 8 EA. 7/16 nuts | 4 EA. 1/2" nuts | |
| 8 EA. 7/16 lockwashers | 4 EA. 1/2" lockwashers | |
| 8 EA. 3/8 flatwashers | 4 EA. 1/2" flatwashers | |

Thank you for choosing PRO COMP Products. Your new Bumper is designed to provide years of satisfaction if properly installed and maintained. See enclosed Product Warranty/Finish Care Guidelines for more information.

CAUTION: BEFORE BEGINNING INSTALLATION, READ INSTRUCTIONS CAREFULLY AND COMPLETELY.

WARNING!! BEFORE TIGHTENING BOLTS OR DRILLING WHERE REQUIRED, MAKE SURE THERE ARE NO OBSTRUCTIONS SUCH AS BRAKE, FUEL, OR ELECTRICAL LINES THAT MIGHT BE DAMAGED OR DESTROYED.

STEP 1: Remove factory bumperettes, if so equipped. NOTE: Most 1998-2000 TJ Wranglers DO NOT come equipped with bumperettes. Use illustration below as a guide to determine left and right and which mounting holes are to be used for your vehicle. Now loosely attach rear mounting brackets to existing holes in the rear of your Jeep using 8 each of the 7/16" x 1-1/2" bolts, 7/16" nuts and lockwashers and 3/8" flatwashers provided. If your late model Jeep Wrangler DOES NOT have the necessary inboard set of holes required, you must drill them. First secure rear brackets at the OUTER set of holes (2) then level bracket and, using holes in bracket as a guide, mark then drill INNER set of holes (2) into Jeep. WARNING: USE CARE TO AVOID DRILLING INTO FUEL TANK. THERE IS A LIMITED AMOUNT OF CLEARANCE. WE RECOMMEND A DRILL STOP IN ORDER TO AVOID THE POSSIBILITY OF DAMAGING FUEL TANK. On TJ models, removal of fuel tank guard/skid plate will ease installation of brackets. Removal of six bolts is necessary. Replace guard in original position using factory bolts after bumper has been installed.

STEP 2: Loosely attach and secure bumper to brackets using remaining 7/16" x 1-1/2" bolts, nuts and lockwashers provided. The bumper brackets which bolt to vehicle will set INSIDE the bumper brackets which are welded to bumper. There are extra sets of holes in each bracket in order to accommodate oversize tires and allow the bumper to be adjustable.

STEP 3: With helpers' assistance, align and level bumper for final positioning, then tighten ALL bolts and nuts. Installation is complete. Periodically check ALL bolts for tightness, taking into consideration your driving habits and conditions.

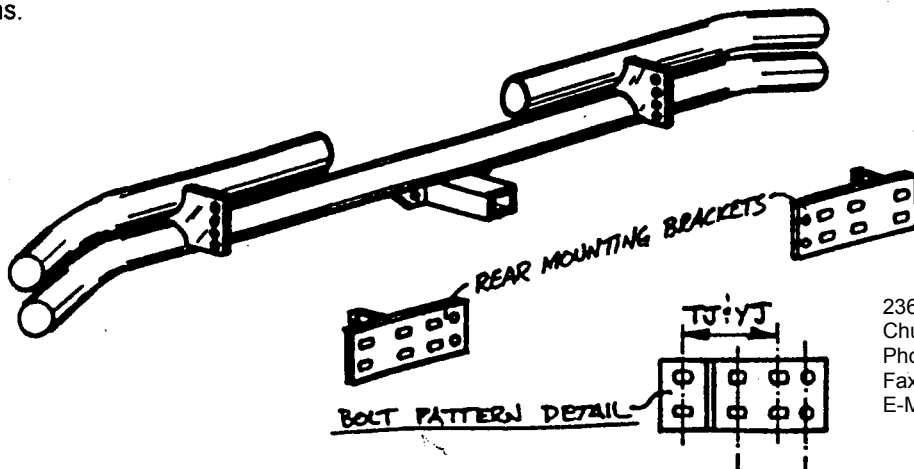

2360 Boswell Road
 Chula Vista, CA 91914
 Phone 619.216.1444
 Fax 619.216.1474
 E-Mail tech@explorerprocomp.com