

2360 Boswell Road  
Chula Vista, CA 91914  
Phone 619.216.1444  
Fax 619.216.1474  
E-Mail tech@explorerprocomp.com



## EXPLORER COMPETITION PRODUCTS

---

**Suspension Systems that Work!**

**Part # 51023 - 6" Lift  
2000-2006 Chevrolet /  
GMC Tahoe / Yukon/  
Avalanche  
2WD Suspension Lift w/  
A-Arm Drops**

**WITH** Electronic Ride Control Option

This document contains very important information that includes warranty information and instructions for resolving problems you may encounter. Please keep it in the vehicle as a permanent record.

## PART LIST

Box 1 of 5-PN 51023-1

Part #	Description	Qty.	Illus.	Page
90-1450	FRONT CROSS MEMBER	1	4	8
90-1496	SWAY BAR SPACER	2	7	9
<b>90-6158</b>	<b>HARDWARE PACK, CENTER LINK DROP</b>	<b>1</b>		
90-2055	1/2" ID X 1 1/2" OD X 3/8" SPACER	2	4	8
90-2014	SPACER, 3/4" OD X 1/2" ID X 1/4"	2	5	9
90-4053	ROD END GUIDE	2	4,5	8,9
96-4036	STEERING CONE REDUCER	4	4	8
<b>90-6170</b>	<b>HARDWARE PACK, UPPER A-ARM DROPS</b>	<b>1</b>		
42-778T	CAM-BOLTS	4	11,12	11
<b>90-6173</b>	<b>HARDWARE PACK, FRONT</b>	<b>1</b>		
70-0372251543	3/8" X 2 1/4" NC SOCKET HEAD CAP SCREW	4	7	9
73-03700034	3/8" SAE GR 8 FLAT WASHER	8		
72-037100816	3/8" NC STOVER NUT	4		
70-0503751800	1/2" X 3 3/4" NC GR 8 HEX BOLT	2	4	8
73-05000038	1/2" GR 8 AN FLAT WASHER	10		
70-0624501800	5/8" X 4 1/2" NC GR 8 HEX BOLT	2	12	11
73-06200034	5/8" SAE GR 8 FLAT WASHER	4		
72-062100816	5/8" NC STOVER NUT	2		
70-0502751800	1/2" X 2 3/4" NC GR 8 HEX BOLT	2	4,5	8,9
73-05000034	1/2" GR 8 FLAT WASHER	4		
72-050100816	1/2" NC STOVER NUT	4		
<b>90-6175</b>	<b>HARDWARE PACK, REAR A-ARM/DIFF DROP</b>	<b>1</b>		
70-0625501800	5/8" X 5 1/2" NC GR 8 HEX BOLT	2	11	11
73-06200034	5/8" SAE GR 8 FLAT WASHER	4		
72-062100816	5/8" NC STOVER NUT	2		
70-0371251800	3/8" X 1 1/4" NC GR 8 HEX BOLT	6	2	7
73-03700034	3/8" SAE GR 8 FLAT WASHER	14		
72-037100816	3/8" NC STOVER NUT	6		
70-0561751800	9/16" X 1 1/2" NC GR 8 HEX BOLT	2	7	9
73-05600042	9/16" USS GR 8 FLAT WASHER	2		
73-05600034	9/16" SAE GR 8 FLAT WASHER	2		
72-056100816	9/16" NC STOVER NUT	2		
72-037100512	3/8" NC GR 5 NY-LOCK NUT	2	3	7
<b>90-6234</b>	<b>HARDWARE PACK, COMPRESSION STRUT</b>	<b>1</b>		
70-0501251800	1/2" X 1 1/4" NC GR 8 HEX BOLT	2	10	10
70-0504001800	1/2" X 4" NC GR 8 HEX BOLT	4	10	10
72-050100816	1/2" NC STOVER NUT	4		
73-05000034	1/2" SAE GR 8 FLAT WASHER	10		
<b>90-6236</b>	<b>HARDWARE PACK, TRACK BAR &amp; TORSION DROP</b>	<b>1</b>		
70-0563501800	9/16" X 3 1/2" NC GR 8 HEX BOLT	1	B	14
70-0563001800	9/16" X 3" NC GR 8 HEX BOLT	2	13	12
72-056100816	9/16" NC STOVER NUT	3		
73-05600034	9/16" SAE GR 8 FLAT WASHER	6		
70-0431251800	7/16" X 1 1/4" NC GR 8 HEX BOLT	2	B	14
72-043100816	7/16" NC STOVER NUT	2		
73-04300034	7/16" SAE GR 8 FLAT WASHER	4		
72-0311001800	5/16" X 1" NC GR 8 HEX BOLT	1	A	14
72-031100816	5/16" GR 8 STOVER NUT	1		
73-03100034	5/16" SAE GR 8 FLAT WASHER	2		
<b>90-1785</b>	<b>REAR CONTROL ARM DROP BRACKET DRIVER</b>	<b>1</b>	<b>F,G</b>	<b>16,17</b>
<b>90-1790</b>	<b>REAR CONTROL ARM DROP BRACKET PASSENGER</b>	<b>1</b>	<b>F,G</b>	<b>16,17</b>
<b>90-6276</b>	<b>HARDWARE PACK, REAR CONTROL ARM DROP BRACKET</b>	<b>1</b>		
70-0563501800	9/16"-12 X 3.5" GR 8 HEXBOLT	2	<b>F,G</b>	<b>16</b>
70-0564001800	9/16"-12 X 4" GR 8 HEXBOLT	2	<b>F,G</b>	<b>16</b>
72-056100816	9/16"-12 GR 8 STOVER NUT	4		
73-05600034	9/16" SAE HARDENED WASHER	8		
70-0501251800	1/2" X 1 1/4" GR 8 HEX BOLT	2		
72-050100816	1/2" GR 8 STOVER NUT	2		
73-05000034	1/2" GR 8 FLAT WASHER	4		
<b>90-6303</b>	<b>HARDWARE PACK, FRONT BRAKE LINE</b>	<b>1</b>		
90-1868	FRONT BRAKE LINE DROP	2	15	13
90-6299	HARDWARE PACK	1		

**Box 2 of 5-PN 51023-2**

Part #	Description	Qty.	Illus.	Page
90-1435	COMPRESSION STRUT MOUNT	2	10	10
90-1455	UPPER A-ARM DROP, DRIVER SIDE	1		
90-1466	UPPER A-ARM DROP, PASSENGER SIDE	1	7	9
90-2196	CENTER STEERING LINK	1	4	8
<b>90-6172</b>	<b>HARDWARE PACK, UPPER A-ARM DROP</b>	<b>1</b>		
70-0431251800	7/16" X 1 1/4" NC GR 8 HEX BOLT	4	7	9
73-04300034	7/16" SAE GR 8 FLAT WASHER	8		
72-043100816	7/16" NC STOVER NUT	4		
70-0561501800	9/16" X 1 1/2" NC GR 8 HEX BOLT	4	7, 8	9,10
70-0563751800	9/16" X 3 3/4" NC GR 8 HEX BOLT	1	NOT USED	
73-05600034	9/16" SAE GR 8 FLAT WASHER	10		
70-0501251800	1/2" X 1 1/4" NC GR 8 HEX BOLT	1		
73-05000034	1/2" SAE GR 8 FLAT WASHER	2		
<b>90-6179</b>	<b>HARDWARE PACK, COMPRESSION STRUT</b>	<b>1</b>		
15-11148	COMPRESSION STRUT BUSHING	8	9,10	10
90-2109	COMPRESSION STRUT SLEEVE	4	9,10	10
90-1476	NUT PLATE-1/2"	3	10	10
15-11018	LOW PROFILE BUMP STOP	2	3	7
<b>90-6235</b>	<b>HARDWARE PACK, SWAY BAR / BRAKE LINE</b>	<b>1</b>		
P-843	SHOCK HARDWARE	2		
60859H	SHOCK SLEEVE	2		
45359	BUSHING, 5/8" "HOURLASS", URETHANE	4		
90-55089-4	REAR BRAKELINE EXTENSION	1	A	14

**Box 3 of 5-PN 51023-3**

90-1459	REAR CROSS MEMBER	1	2,3,11	7,11
90-2126	COMPRESSION STRUT	2	10	10
90-1606	TORSION BAR DROP BRACKET	2	13	12
90-2311	SWAY BAR EXTENSIONS	2	E	16
90-1682	TRACK BAR RELOCATION BRACKET	1	B,D	14
<b>90-6281</b>	<b>HARDWARE PACK, BUMPSTOP</b>	<b>1</b>		
90-3146	BUMP STOP SPACER	4	C	15
90-1702	NUT PLATE	2	C	15
70-0371001800	3/8" X 1" GR 8 HEX BOLT	4	C	15
73-03700836	3/8" GR 8 SPLIT WASHER	4		
<b>90-6275</b>	<b>HARDWARE PACK, WASHERS</b>	<b>1</b>		

**Box 4 of 5-PN 51023-4**

14121	REAR COIL SPRINGS	2		
-------	-------------------	---	--	--

**Box 5 of 5-PN 51023-5**

90-1670	FRONT SHOCK RELOCATION BRACKET,DRIVER	1		
90-1674	FRONT SHOCK RELOCATION BRACKET,PASS.	1	8	10
<b>90-6278</b>	<b>HARDWARE PACK, REAR SHOCK BRACKET, DRIVER</b>	<b>1</b>		
90-1678	INNER SIDE PLATE, DRIVER	1		
90-1679	OUTER SIDE PLATE, DRIVER	1		
90-2315	SPACER, 1" OD X 3/16" WALL X 1 7/16"	1		
<b>90-6278</b>	<b>HARDWARE PACK, REAR SHOCK BRACKET, PASSENGER</b>	<b>1</b>		
90-1680	INNER SIDE PLATE, PASSENGER	1	H	18
90-1681	OUTER SIDE PLATE, PASSENGER	1	H	18
90-2315	SPACER, 1" OD X 3/16" WALL X 1 7/16"	1	H	18
<b>90-6239</b>	<b>HARDWARE PACK, SHOCK RELOCATION</b>	<b>1</b>		
70-0561251800	9/16" X 1 1/4" NC GR 8 HEX BOLT	6	8,H	10,18
70-0563251800	9/16" X 3 1/4" NC GR 8 HEX BOLT	2	H	18
72-056100816	9/16" GR 8 STOVER NUT	8		
73-05600034	9/16" SAE GR 8 FLAT WASHER	16		
70-0621501800	5/8" X 1 1/2" NC GR 8 HEX BOLT	2	8	10
72-062100816	5/8" GR 8 STOVER NUT	2		
73-06200034	5/8" SAE GR 8 FLAT WASHER	4		
73-06200042	5/8" USS GR 8 FLAT WASHER	2		
<b>90-6240</b>	<b>HARDWARE PACK, RIDE CONTROL EXTENSION LINK</b>	<b>1</b>		
90-4058	EXTENSION LINK ASSEMBLY, FRONT	2	14,16	12,13
90-4060	EXTENSION LINK ASSEMBLY, REAR	2	14,I	12,18
72-10200512	10-32 NY-LOCK NUT	4	14,I	12,18

## Introduction:

- ◆ This installation requires a professional mechanic!
- ◆ We recommend that you have access to a GM service manual for your vehicle to assist in the disassembly and reassembly of your vehicle. It contains a wealth of detailed information.
- ◆ Ensure that your work space is of adequate size and the work surface is level. Place the vehicle in neutral. Place your floor jack under the front cross member and raise vehicle. Place jack stands under the frame rails behind the front wheel wells and lower the frame onto the stands. Remove the jack and place the vehicle back in gear, set the emergency brake, and place blocks both in front and behind the rear wheels.
- ◆ Prior to installation, carefully inspect the vehicle's steering and driveline systems paying close attention to the tie rod ends, ball joints, wheel bearing preload, pitman and idler arm. Additionally, check steering-to-frame and suspension-to-frame attaching points for stress cracks. The overall vehicle must be in excellent working condition. Repair or replace all worn or damaged parts!
- ◆ Read the instructions carefully and study the illustrations before attempting installation! You may save yourself a lot of extra work.
- ◆ Check the parts and hardware against the parts list to assure that your kit is complete. Separating parts according to the areas where they will be used and placing the hardware with the brackets before you begin will save installation time.
- ◆ Check the special equipment list and ensure the availability of these tools.
- ◆ Secure and properly block vehicle prior to beginning installation.
- ◆ **ALWAYS** wear safety glasses when using power tools or working under the vehicle!
- ◆ Use caution when cutting is required under the vehicle. The factory undercoating is flammable. Take appropriate precautions. Have a fire extinguisher close at hand.
- ◆ Foot pound torque readings are listed on the Torque Specifications chart at the end of the instructions. These are to be used unless specifically directed otherwise. Apply thread lock retaining compound where specified.
- ◆ **Please note that while every effort is made to ensure that the installation of your Pro Comp lift kit is a positive experience, variations in construction and assembly in the vehicle manufacturing process will virtually ensure that some parts may seem difficult to install. Additionally, the current trend in manufacturing of vehicles results in a frame that is highly flexible and may shift slightly on disassembly prior to installation. The use of pry bars and tapered punches for alignment is considered normal and usually does not indicate a faulty product. However, if you are uncertain about some aspect of the installation process, please feel free to call our tech support department at the number listed on the cover page. We do not recommend that you modify the Pro Comp parts in any way as this will void any warranty expressed or implied by the Explorer Competition Products company.**

## Please Note:

- ◆ Front end and headlight realignment is necessary.
- ◆ Speedometer and ABS recalibration will be necessary if larger tires (10% more than stock diameter) are installed
- ◆ This suspension system utilizes the stock torsion bars which normally afford the best ride quality. If, after kit is installed, ride or handling seems too "soft", heavier Gross Vehicle Weight Rating (GVWR) bars can be installed. GM offers various bars for up to 10,000 lbs. GVWR.
- ◆ **Due to differences in manufacturing, dimensions and inflated measurements, tire and wheel combinations should be test fit prior to installation.** Tire and wheel choice is crucial in assuring proper fit, performance, and the safety of your Pro Comp equipped vehicle. For this application, a wheel not to exceed 8" in width with a minimum backspacing of 4" must be used. Additionally, a quality tire of radial design, not exceeding 35" tall X 12.5" wide is recommended. Please note that the use of a 35" X 12.5" tire may require fender modification. Violation of these recommendations will not be endorsed as acceptable by Explorer Pro Comp and will void any and all warranties either written or implied.

## Special Equipment

A special removal tool is required for safe removal and installation of the torsion adjuster arms. This special puller can be purchased from your local GM dealer (Tool #J36202) or from Kent Moore Tool Group in Roseville, MI. (800) 345-2233 or (313) 774-9500 (Part #J22517-C). You may be able to rent one of these at your local parts store. Please refer to your GM service manual for more information.

### WARNING:

**Be extremely careful when loading or unloading the torsion bars! There is a tremendous amount of stored energy in the bars. Keep your hands and body clear of the adjuster arm assembly and puller tool in case anything slips or breaks! Remember your safety glasses!**

**Torque specifications are provided on page 19**

### Front Installation:

1. Ensure that your work space is of adequate size and the work surface is level. Place your floor jack under the front cross member and raise vehicle. Place jack stands under the frame rails behind the front wheel wells and lower the frame onto the stands. Remove the jack and place the vehicle back in gear, set the emergency brake, and place blocks both in front and behind the rear wheels.

2. Measure and record the distance from the center of each wheel to the top of its fender opening. Record below.

LF: \_\_\_\_\_ RF: \_\_\_\_\_

LR: \_\_\_\_\_ RR: \_\_\_\_\_

3. Remove any skid plates or debris shields from the vehicle.
4. Mark the torsion bars orientation for later reinstallation. Measure the torsion bar adjusting screw depth and record this dimension for use when replacing the torsion adjuster arm on reassembly. Remove the torsion bar adjusting screw. Apply a small amount of lubricating grease to the puller (See note above) threads and the puller shaft-to-adjuster arm contact point. Load the puller and torsion adjuster arm until the adjuster nut can be easily removed from the cross member. Back the puller off

to unload the torsion bar and set the puller aside. With the bar unloaded, slide it forward into the lower control arm until the adjuster arm falls free. If the bar seems stuck, use a hammer and punch through the hole in the rear of the cross member to dislodge it. Repeat this procedure on the other side of the vehicle. Record below.

LEFT: \_\_\_\_\_ RIGHT: \_\_\_\_\_

See Illustration 1.

5. **Warning! Be extremely careful when unloading or loading the torsion bars on your vehicle. There is a tremendous amount of stored energy! Keep your hands and body clear of the adjuster arm assembly and puller tool in case anything slips or breaks!**
6. Remove the torsion bar cross member by removing the through bolts on each side of the vehicle. Save these nuts and bolts for re-use on reassembly. With the cross member out of the way, the torsion bars can be pulled from the lower control arms and removed.
7. Disconnect the ABS sensor wire and secure it out of the way to prevent damage to the wiring or connector ends.
8. Remove the brake caliper assembly from the rotor and secure it away from the work

---

**Mark the orientation of both torsion bars (i.e., left side, right side, and front). They must be reinstalled exactly as removed!**

---

area.

**Note: Be careful with the brake lines! Do not kink or strain these components.**

9. Carefully remove the ride sensor link located at the rear of the wheel well. Be very careful not to damage the sensor!
10. Detach the outer end of the tie rod from the spindle assembly. Special tools are available to safely remove these without damage to the joint or the protective boot. Your GM service manual has details on this procedure.
11. Remove the sway bar links that connect the sway bar to the lower A-arm. Save this hardware for re-use on reassembly.
12. Disconnect the Ride Control wiring harness from the shock stem. Remove the shock absorber mounting bolts and remove the shocks from the vehicle. Save these parts for re-use.
13. Remove the upper and lower A-arm pivot nuts. Save this hardware for re-use on reassembly.
14. Support the A-arm assembly and carefully remove the pivot bolts. Lower the assembly to the floor and set aside. This assembly is relatively heavy and not rigid. Be **very** careful when removing it. Save the pivot bolts for re-use.
15. Remove the factory bump stops by using a large channel lock type of pliers and discard the stops.
16. Remove the drag link from the pitman arm and idler arm. Set this assembly aside. Save the nuts for re-use.  
**Note: Sometimes, it may be easier to remove the Idler arm from the frame while still fastened to the drag link.**
17. Remove the rear frame brace cross member and discard this hardware.
18. Using a 2" hole saw **without** the pilot drill, remove the bump stop mount from the frame on each side of the vehicle. It is important that you do not remove any more

---

**Repeat steps 8 through 16 on the remaining side of the vehicle:**

---

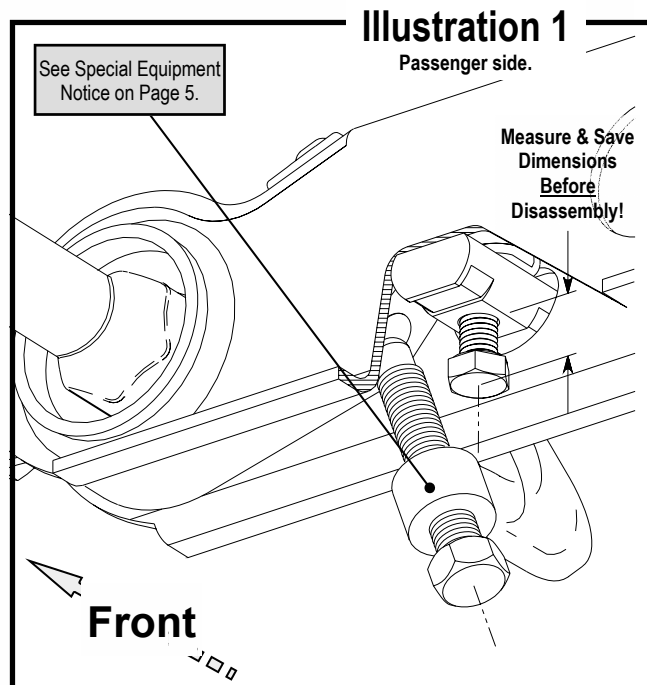

material than you have to.

**IMPORTANT: Do NOT drill through this pad with the hole saw!**

19. Using an angle grinder or equivalent, remove any remaining weld from this area to achieve a smooth surface.
20. On the OE bump stop flanges on both sides of the truck, cut the front corners where indicated in **Illustration 2** to assure adequate shock clearance.
21. On the front upper A-arm mount pockets, knock the existing alignment cam pins off with a hammer and grind the surface smooth. Make sure you are wearing your safety glasses!
22. Install the provided replacement bump stops (**PN 15-11018**) to the rear cross member as indicated in **Illustration 3**.  
**Note: It is important that this is done now as it is not possible to install these stops after the installation of the cross member.**
23. Temporarily mount the rear cross member (**PN 90-1459**) to the frame using the existing lower A-arm pockets and OE pivot bolts. Make sure that the cross member is located with the inside face of the rear flange even with the rear edge of the OE

bump stop flange as noted in **Illustration 2** (the driver side should look the same as the passenger side when properly located). When the location is set, clamp the cross member to the flanges to prevent movement and drill the 2 upper mount holes through the OE flange on both sides of the truck. The bottom hole is not accessible with a drill at this time, it must be marked for later drilling. Install the **3/8" X 1 1/4"** NC bolts, washers and Stover nuts provided and tighten them to prevent movement. On the driver side, tighten up the bottom OE through bolts until there is about .030" clearance between the cross member and factory pocket sides.

24. Drill the remaining 3/8" holes marked in the previous step through the OE flanges on both sides of the vehicle.

**Note: It is very important that these bolts are installed. Do not skip this step.**

25. Reinstall the rear cross member into the truck. Use the OE pivot bolts to hold it in place. Finish installing the **3/8" X 1 1/4"** nuts, bolts, and washers to the upper flange mounts on both sides of the vehicle and torque all cross member hardware to specifications on page 19.
26. Install the Pro Comp. center link drop (PN 90-2196) to the pitman arm and idler arm using the factory nuts. See **Illustration 4**.  
**Note: When properly installed, the drop is perpendicular to the ground.**
27. Mount the front cross member (PN 90-1450) to the existing front lower A-arm pockets with the OE pivot bolts and nuts. Tighten to specs. Using the cross member as a guide, drill through the factory frame material and install the **1/2" X 2 3/4"** bolts provided at this time. See highlighted note in **Illustration 4** for the location.

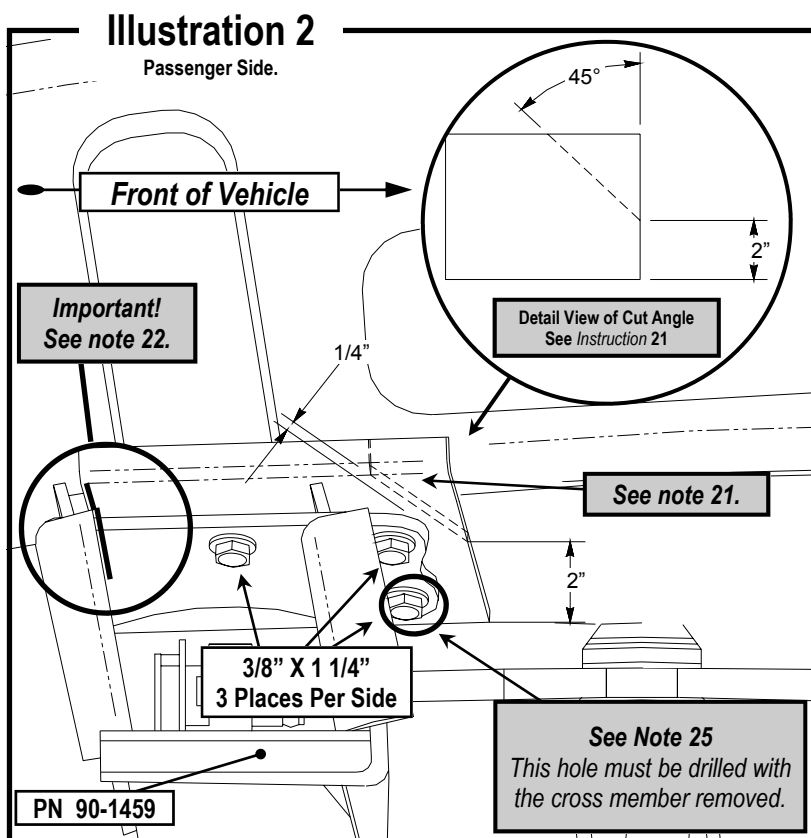

28. Loosely install the OE center link to the center link drop using the supplied **1/2" X 3 3/4"** Bolts and other hardware supplied (PN's 90-2055, 96-4036, 90-4053, & 1/2" AN washers) as indicated in **Illustration 4**. Leave the lock nuts loose for the mo-

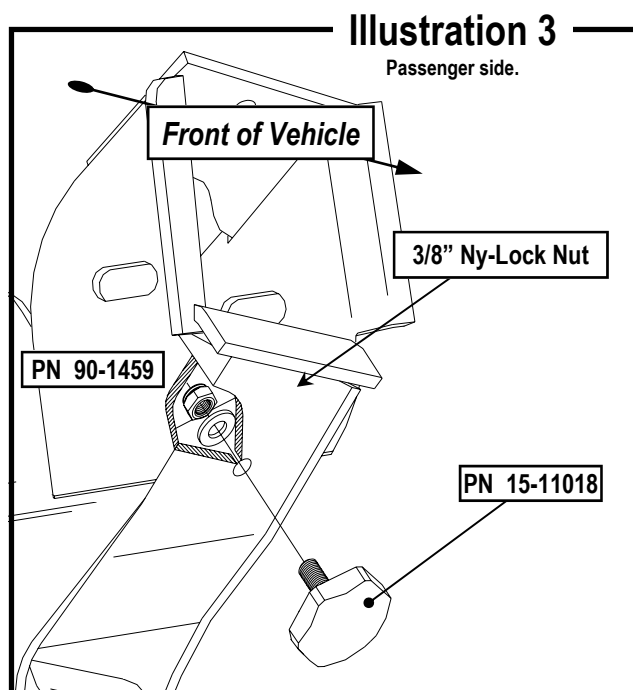

### Illustration 4

Passenger Side.

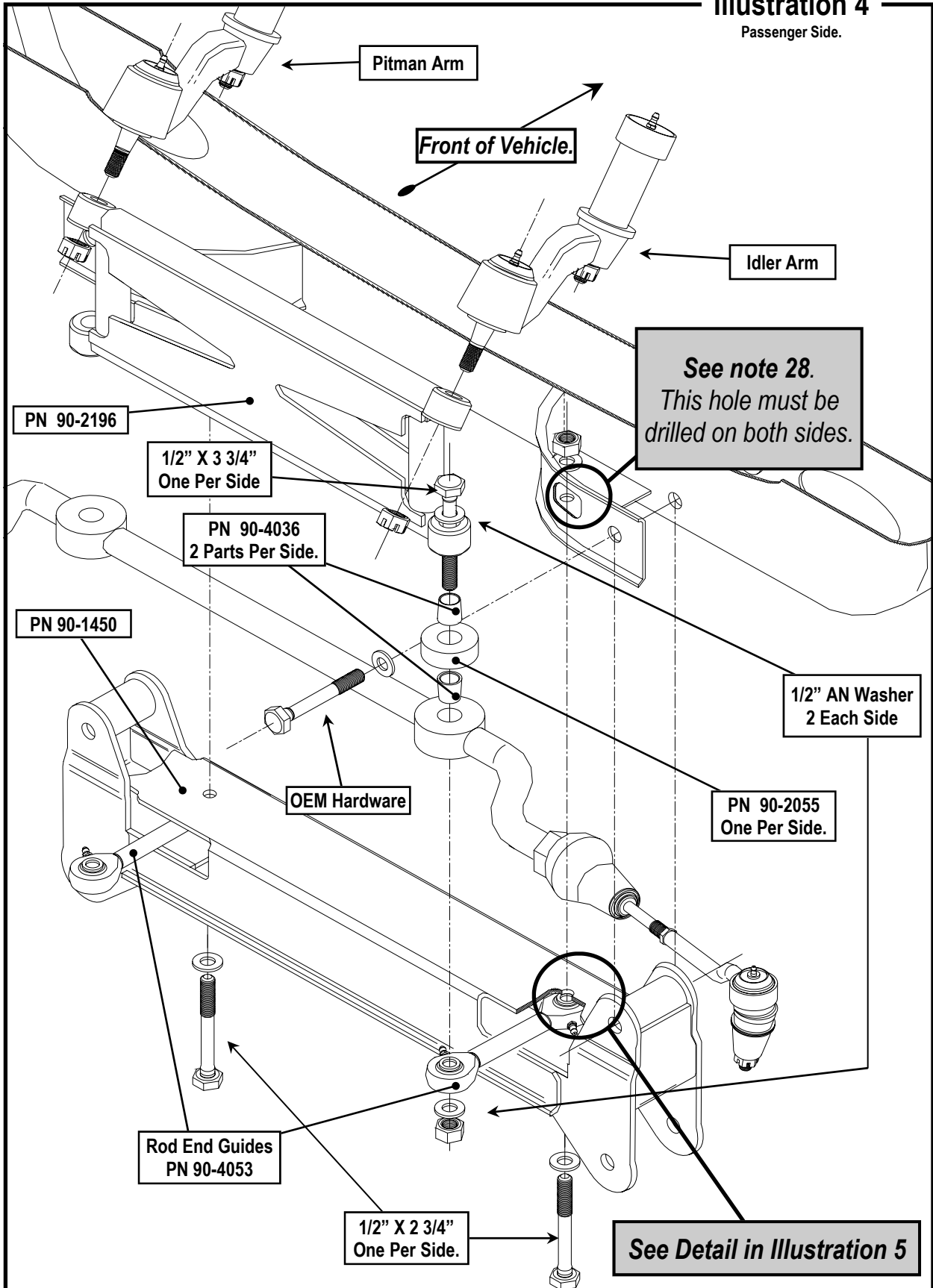

ment.

**Note: For correct operation, follow this illustration exactly!**

29. Now install the rod end guides (**PN 90-4053**) to the front cross member as shown in **Illustrations 4 & 5**. Use the supplied **1/2" X 2 3/4"** bolts, spacers (**PN 90-2014**), washers, and nuts. Place the ends of the rod ends onto the drop link bolts. Snug up the bolt assemblies and rotate the steering assembly back and forth several times to check for clearance. Additional washers are supplied to facilitate the correction of any misalignment issues you may encounter. It is very important to ensure no binding occurs throughout the entire range of motion of the steering assembly. Once correct clearances are established. Torque all fasteners to specifications.
30. At the front of the OE A-arm stop, it will be necessary to grind the existing droop stop tab back enough to clear the new hardware as shown in **Illustration 6**.
31. Install the front, upper A-arm drops (**PN 90-1466 pass. and 90-1455 dvr.**) to the existing upper pockets using one of the supplied **9/16" X 1 1/2"** bolts with washers and nut at the front, and the **7/16" X 1 1/4"** bolts, washers, and nuts from the bottom of the adapter through the existing holes in the OE frame. The back hole in the adapter must be drilled as indicated in **Illustration 7**. Leave these fasteners slightly loose until the sway bar and shock relocation brackets are installed.
32. Install the shock relocation brackets (**PN 90-1670 - Driver, and 90-1674 - Passenger**) between the OE upper A-arm mounts and under the OE shock mount. Use the **9/16" X 1 1/4"** bolts, washers and nuts in each of the 3 mount locations. Use **Illustration 8** as a reference. Again, leave the fasteners loose until the sway bar is in place.
33. The factory sway bar is remounted upside down using the OE bushings and clamps. They mount to the original location with spacers (**PN 90-1496**)

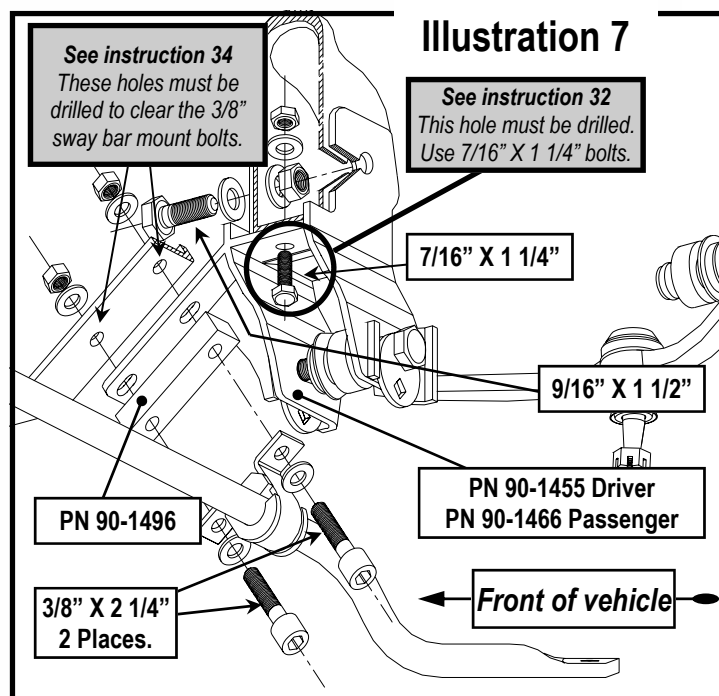
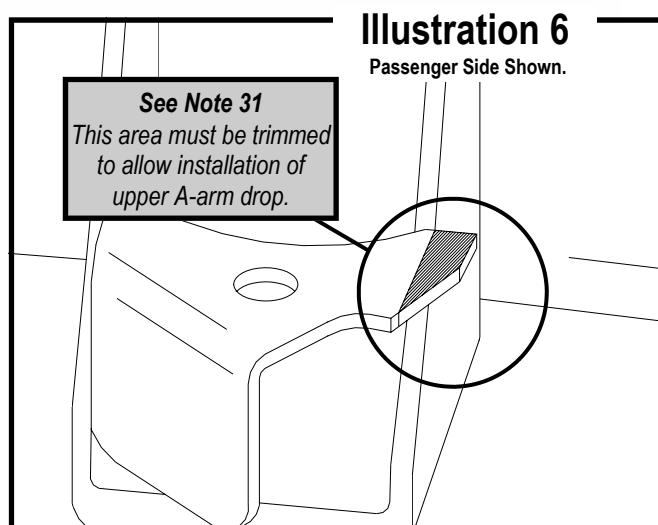
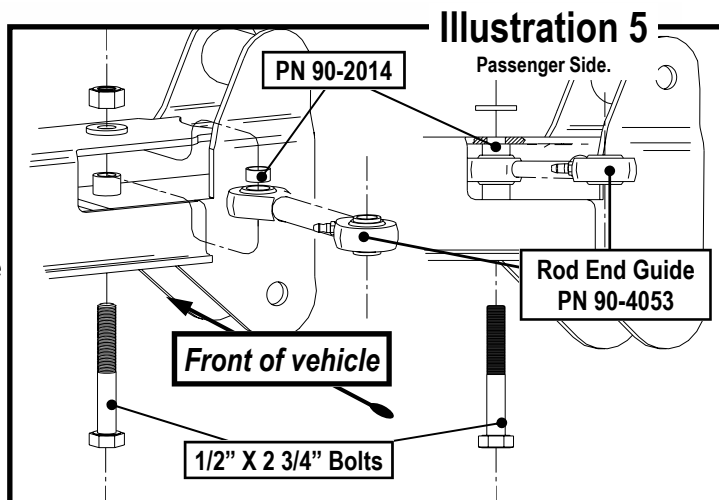

and supplied **3/8" X 2 1/4"** socket head cap screws, washers, and lock nuts. Drill out the sway bar mounting threads to clear the 3/8" bolts (13/32"). See **Illustration 7**. For the moment, tighten the bushing bolts enough to keep the sway bar from swinging but loose enough to facilitate the installation of the end links. At this point, tighten all A-arm and shock relocation hardware to specs. Do not tighten the sway bar hardware until the end links are in place.

34. Assemble the compression strut bushings and sleeves into the struts as shown in **Illustrations 9 & 10** using the components in part pack **PN 90-6179**.
35. Position the compression struts (**PN 90-2126**) into the tabs on the front cross member using the supplied **1/2" X 4"** bolts, washers, and nuts. See **Illustration 9**. The strut end with the tube ends welded at an angle go to the front, the struts are angled from the front mounts to the **outside** of the vehicle. Loosely place the compression strut mounts (**PN 90-1435**) onto the transmission cross member using the supplied **1/2" X 1 1/4"** bolts, washers, and tab nuts. See **Illustration 10**. The

**Illustration 8**

Passenger Side.

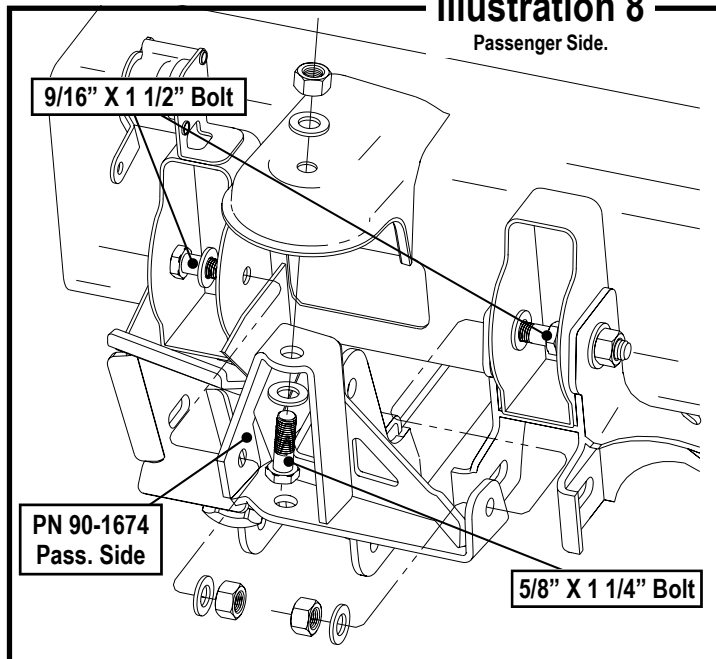

**Illustration 9**

Front Cross Member

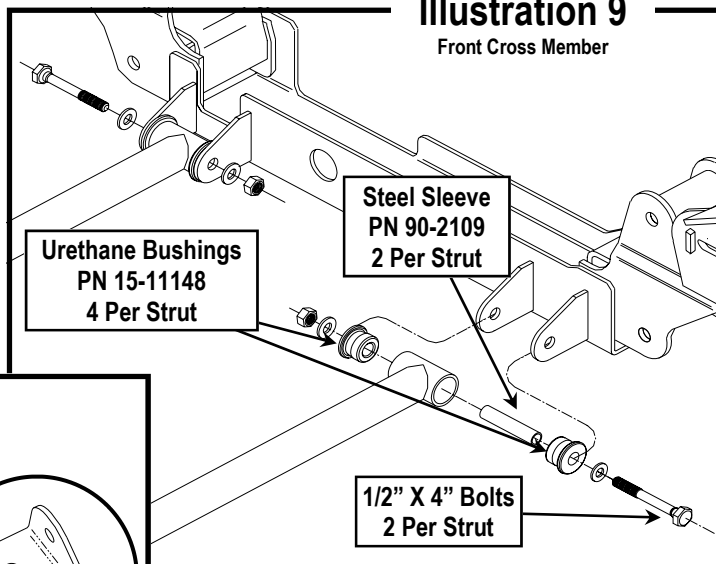

**Illustration 10**

Rear Strut Mount

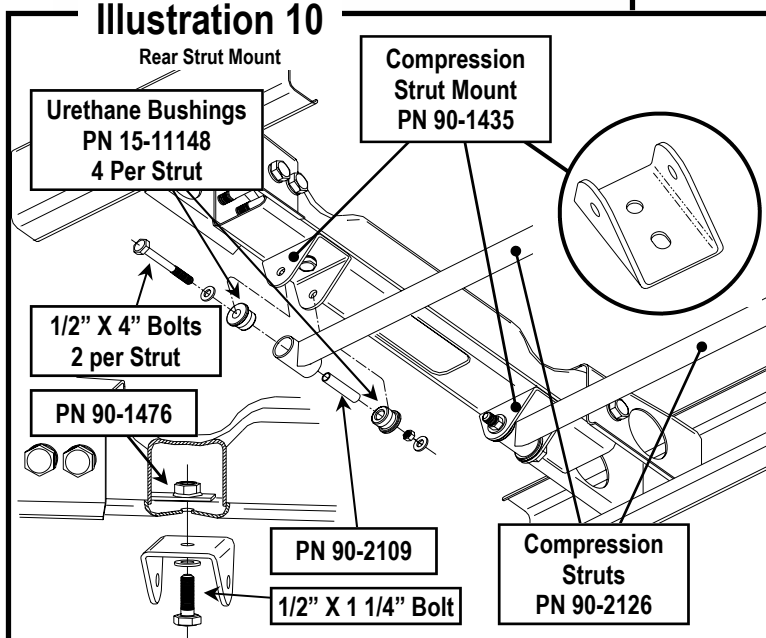

location of the rear mount is dependant on the transmission option in your vehicle.

36. Swing one compression strut up to its previously installed mount and position the mount to ensure easy insertion of the compressions strut cross bolts. You may have to rotate the saddle or use the other hole (or slot) to achieve a satisfactory fit. Snug the bolts up to prevent movement, swing the strut back out of the

way and torque the rear strut mount bolt to specifications being careful to maintain its position. Repeat this procedure for the other side. Reinstall the struts with the remaining **1/2" X 4"** bolts, washers, and nuts and torque all strut fasteners to specifications.

37. At this point, check all mounting hardware and adapters for correct fit and check all fasteners to make sure they are in place and correctly tightened.
38. Install the A-arm assemblies on each side of the vehicle by reversing the disassembly order. Attach the lower A-arms using the supplied **5/8" X 5 1/2"** bolts to the rear, **5/8" X 4 1/2"** bolts to the front with washers and nuts. The upper A-arms are installed using the new alignment cam bolt (**PN 42-778T**) assemblies. They are installed with the threads **away** from the center of the A-arm as shown in **Illustration 11**. Be careful not to damage the ABS sensor wire. **DO NOT** tighten the pivot bolts at this time. For correct positioning of the rubber bushings, the vehicle should be fully on the ground before these bolts are torqued to specifications.

**Note: If there is excessive space between the upper a arm and the new cross member pocket, shim the space out with the contents of an 90-6275.**

39. Install the sway bar link to the sway bar and lower A-arm with the OE links. Tighten these until the bushings just start to bulge out.  
**Note: Do not over tighten!**
40. Install the OE Ride Control shock absorber to the relocation bracket and to the lower A-arm using the OE mount hardware.  
**Note: Remember to reinstall wiring!**
41. Install the tie rod ends to the steering knuckle and torque to factory specifications.
42. Install the front caliper assemblies to each side of the truck. Tighten them using the factory support clamps.

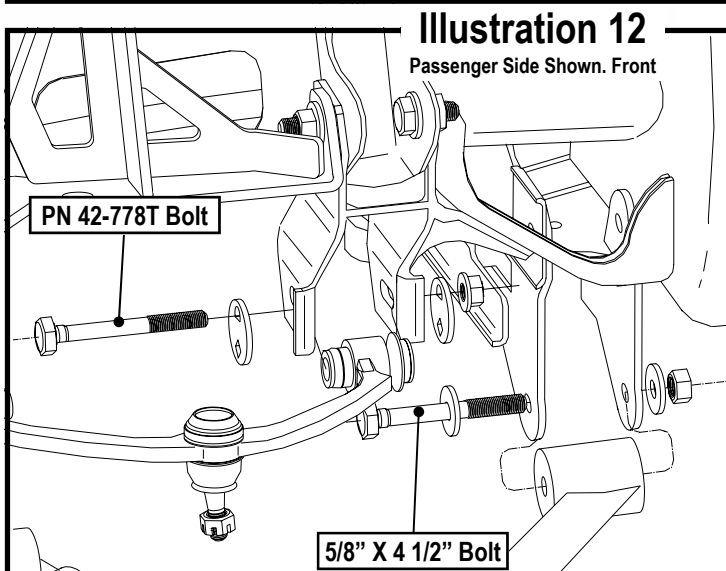
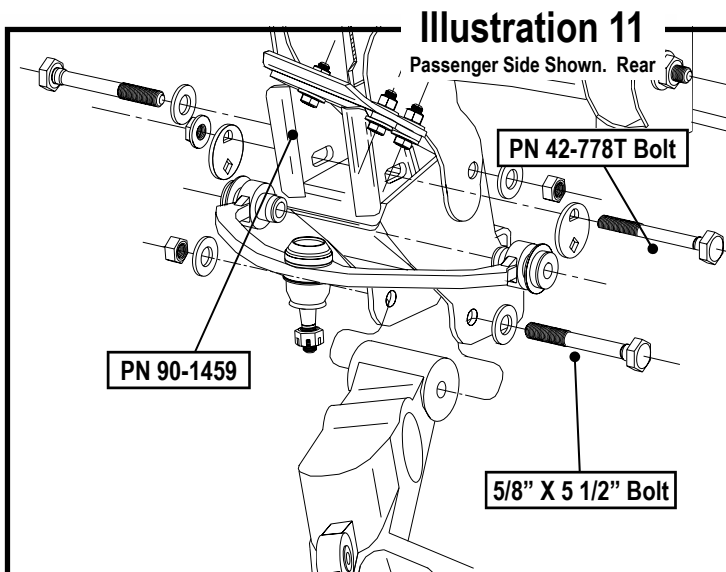

43. Remove the factory brake line brackets from the frame. Using the supplied brackets (**PN 90-1868**) and the previously removed factory bolt attach the new bracket in place of the stock bracket with the bends facing down. Attach the stock brake line bracket to the new bracket using the new hardware (**PN 90-6299**).
44. Install the ABS sensor wiring and secure them to the brake lines with "zip-ties". Again, the harness must be routed to prevent breakage or chaffing. Move the A-arm assembly up and down to its limits several times with the spindle full left and full right, to check for binding and to ensure that there are no interference or pinching problems with the brake lines

and ABS wiring.

45. Install the torsion bar cross member drops by locating the new parts (**PN 90-1606**) in place as shown in **Illustration 13**. Use the supplied **9/16" X 3"** bolts but leave them loose for the moment.
46. Reinstall the factory torsion bar cross member with the OE fasteners at the bottom.  
**Note: the weld nut is oriented to the rear of the vehicle.**
47. Install the Torsion bars by reversing the order in which they were removed. Again, be very careful to install them with the same orientation that they were removed (I.E. left front to left front, right front to right front). Reset the ride height adjustment bolts to the same measurements previously taken.

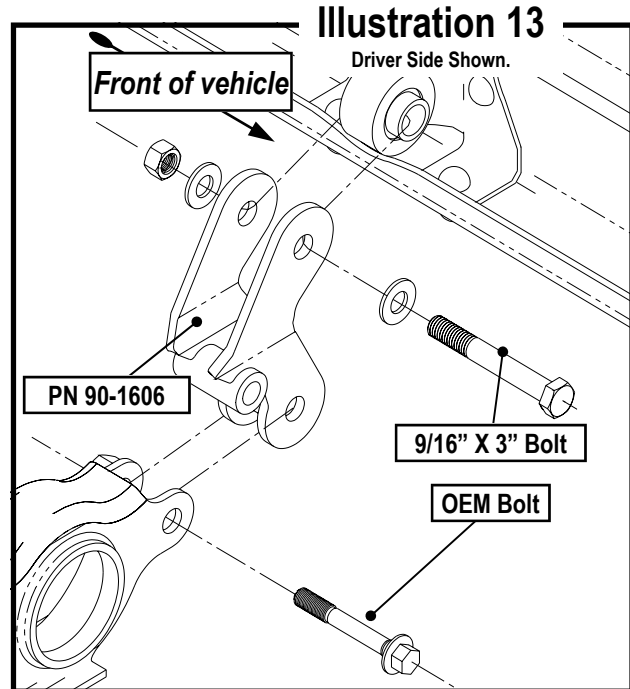

48. Install the extension link assemblies for the ride height sensors (**PN 90-4058 (Long)**) using the 10-32 Ny-lock nuts provided. The links are oriented as shown in **Illustration 14** with the studs opposite each other.

**Notes: A) Be cautious with these sensors. Do not damage them or their wiring.**

**B) The lengths of the replacement links are preset at the factory. Do not change!**

49. With the truck still on jack stands and the suspension hanging at full extension, cycle the steering from lock to lock to check that all components have clearance and operate freely. Pay very close attention to the ABS wiring and brake lines.
50. Reinstall your wheels and tires and properly torque the lug nuts to factory specs. Again check all areas around the suspension and tires for clearance issues.
51. Lower the truck to the ground to preload the suspension and unload the upper A-arms. Tighten the lower A-arm pivot bolts to specifications. It is necessary to rotate the upper A-arm alignment cam bolts to a neutral position (in the center of the align-

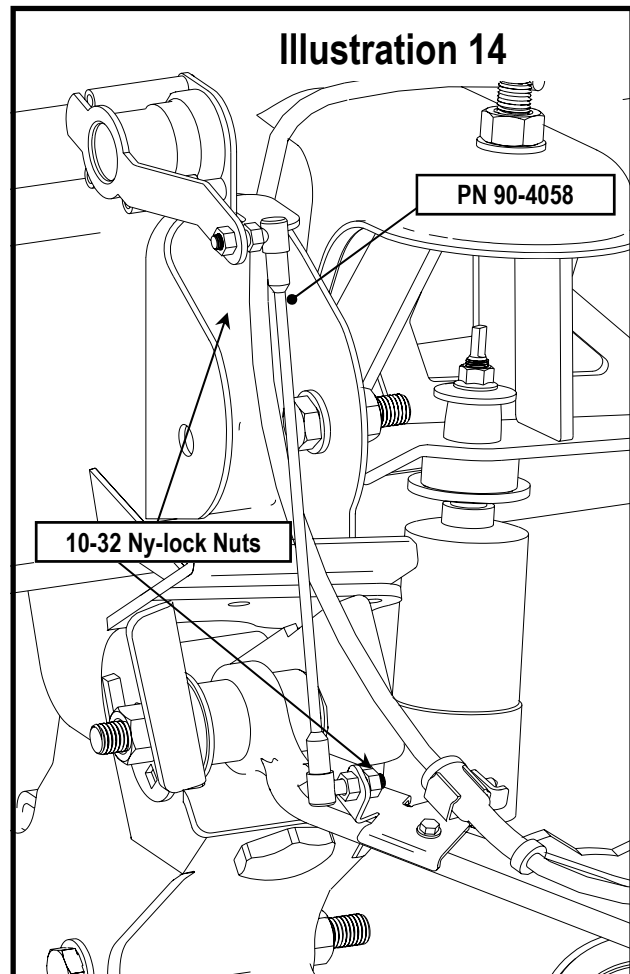

ment slot) and then tighten the cam bolts to specifications. This step is necessary to allow you to get to a professional alignment shop only! Do not assume that this setting is "close enough" and skip the alignment.

---

**IMPORTANT: REMEMBER TO PUMP THE BRAKES UP BEFORE DRIVING YOUR VEHICLE!**

---

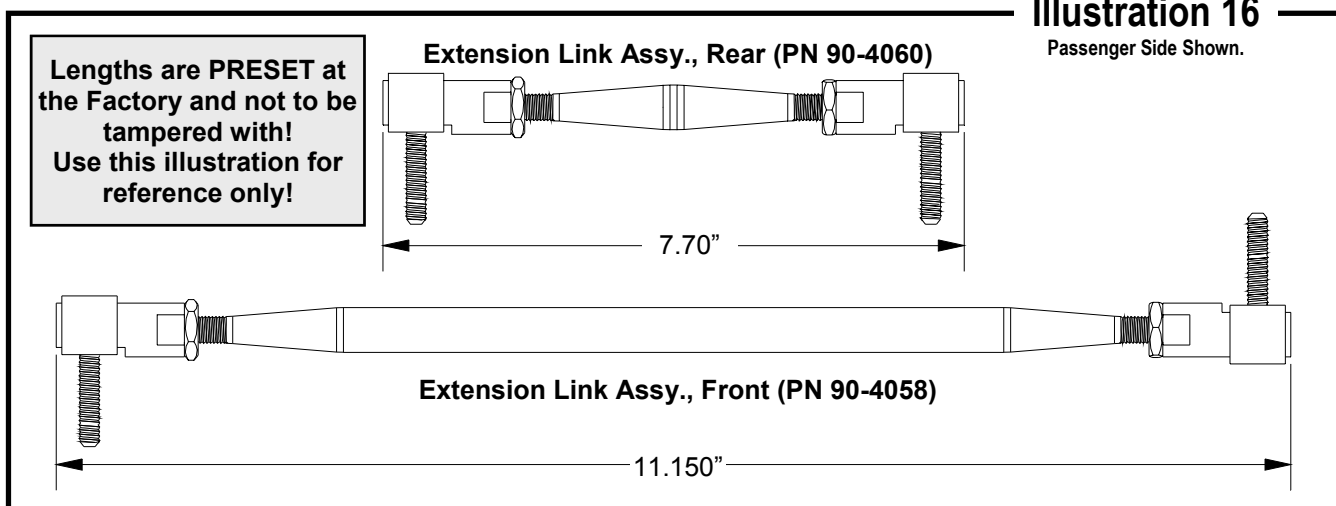
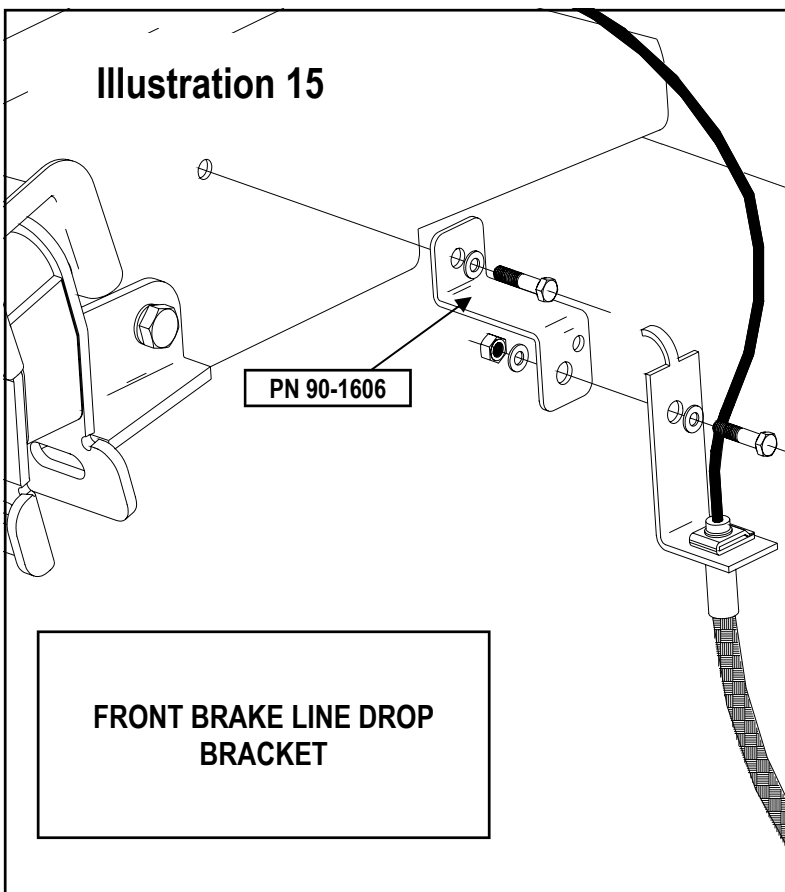

## Rear kit installation

1. Raise the rear of the vehicle enough for the tires to clear the ground and use jack stands on the frame to support the truck. Remove the rear tires and wheels.
2. Support the differential with your floor jack and remove the OEM shock absorbers. It may be necessary to raise the differential housing slightly to facilitate their removal.
3. Carefully remove the ride control links. Discard these OE links.
4. Completely remove the sway bar links from both ends of the sway bar. Save the fasteners.
5. Remove the OE bolts from the differential track bar at the upper track bar mount. Save this hardware.
6. Remove the brake line mount bolt at the upper front location of the vehicle gas tank. See **Illustration A**.
7. Carefully lower the differential away from the vehicle and remove the stock springs.

**Important: Be very careful not**

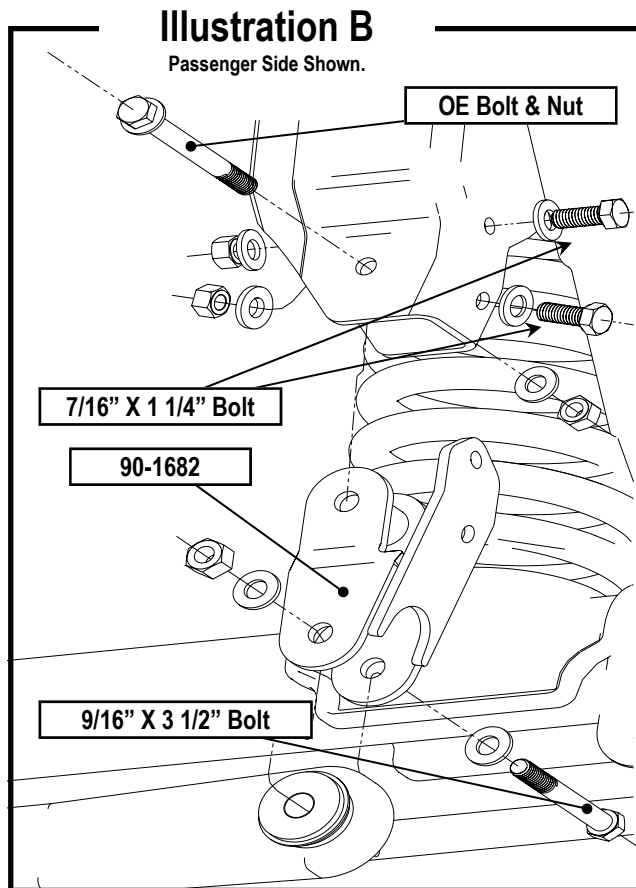
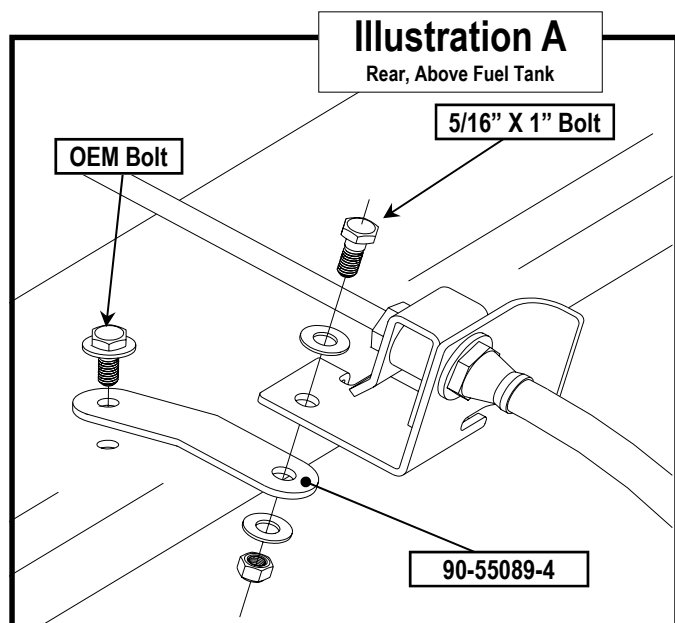

**to damage the brake lines! Remove mounting brackets as needed to allow the brake lines freedom of movement sufficient to avoid damage. Remember to reinstall them when done.**

8. Using **Illustration C** as a guide, install the bump stop extension plates (**PN 90-3146**) to the existing bump stop by first installing one **3/8" X 1"** bolt and lock washer through one of the holes in the bump stop extension. Slide the nut plate (**PN 90-1702**) between the OE bump stop and the lower trailing arm until the back nut lines up with the hole in the OE bump stop. Take the bump stop extension with its bolt and place it on top of the

### Illustration C

Passenger Side Shown.

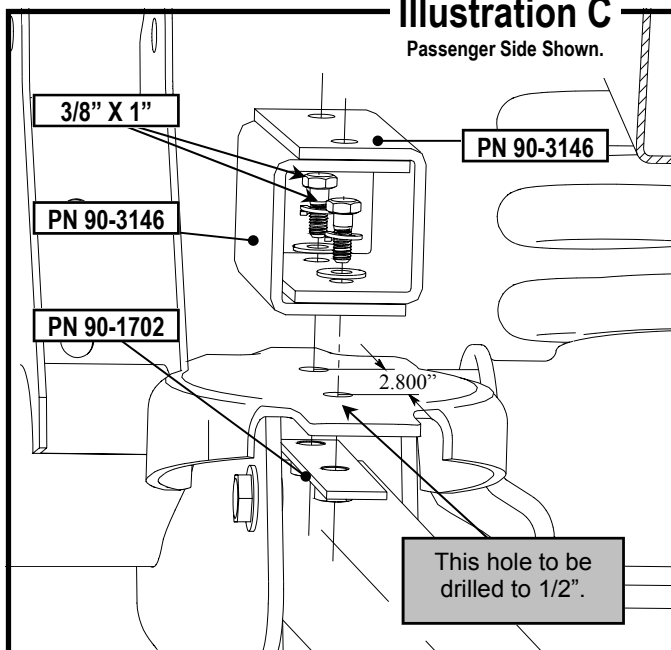

pad and start the bolt into the nut plate. Rotate the nut plate to the location of the previously drilled front hole and start the second **3/8" X 1"** bolt with lock washer into the remaining nut on the nut plate. Tighten these bolts to 45 ft-lbs

9. Using **Illustration C** as a guide, install the bump stop extension (**PN 90-2156**) to the existing bump stop by first installing one **3/8" X 1"** bolt and lock washer through one of the holes in the bump stop extension. Slide the nut plate (**PN 90-1702**) between the OE bump stop and the lower trailing arm until the back nut lines up with the hole in the OE bump stop. Take the bump stop extension with its bolt and place it on top of the pad and start the bolt into the nut plate. Rotate the nut plate to the location of the previously drilled front hole and start the second **3/8" X 1"** bolt with lock washer into the remaining nut on the nut plate. Tighten these bolts to 45 ft-lbs
10. Repeat this procedure on the remain-

ing side of the vehicle.

11. On the rear of the drivers side frame rail, loosen and disconnect the parking brake adjustor cable connector and nut. Compress the retaining fingers on the rear cables and pull the parking break cables away from the frame.
 

**NOTE:**  
**Mark the upper and lower cables so they can be put back in the same orientation.**
12. Remove the nuts and bolts attaching the upper and lower rear control arms on the driver's side of the frame. Do not remove the control arms from the passenger side .
13. Loosen the bolt attaching the lower control arm to the axle bracket. Allow the lower control arm to hang downward.
14. Attach the control arm drop bracket (**DRIVER'S PN 90-1785 and PASSENGER PN 90-1790**) to the frame using the original bolts. **SEE ILLUSTRATION G.**
15. Drill a 1/2" hole through the bottom of the lower frame bracket hole and the frame. Install the 1/2" hardware from hardware pack **90-6276**.

### Illustration D

Finished View Shown.

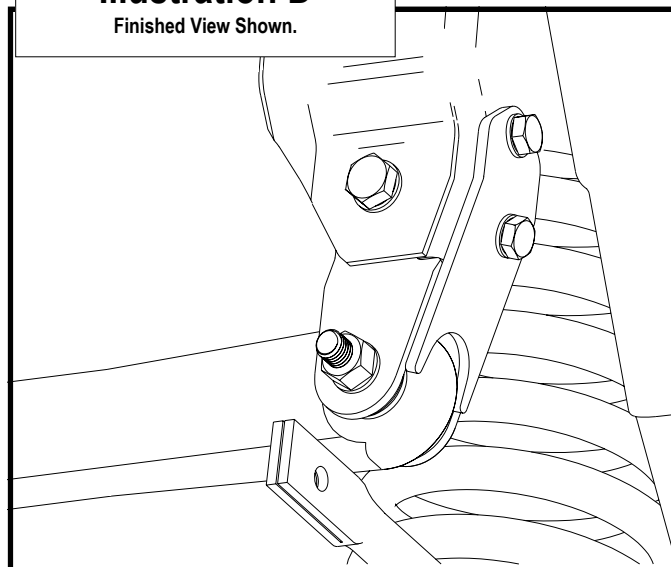

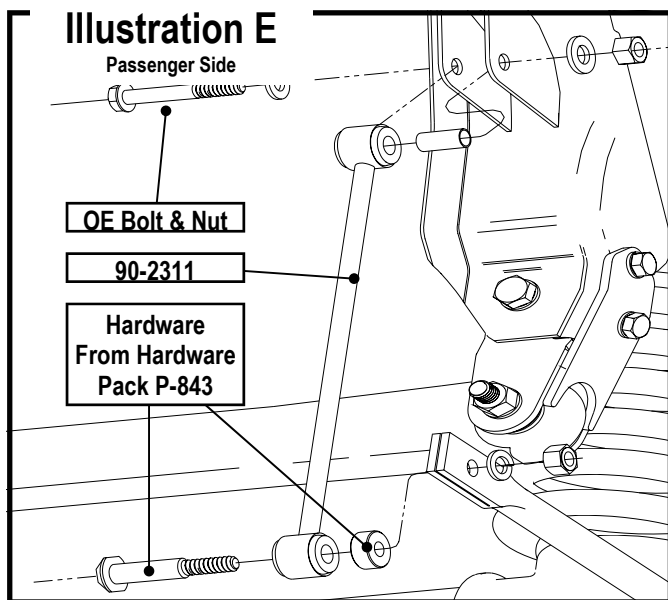

16. Tighten the 1/2" nut and bolt to 65 ft-lbs and the original bolts to 80 ft-lbs.
17. Pull the parking brake cables through the new control arm drop bracket, the top cable through the bracket and the bottom cable through the hole in the side of the bracket. Connect the parking brake cable connector and nut. Adjust parking brake tension to factory specifications.
18. Loosely attach the upper control arm to the control arm drop bracket with the 9/16" X 3.5" bolt, washer and nut from hardware pack 90-6276.  
**NOTE: Do not tighten the pivot bolts until the vehicle is at its new ride height.**
19. Loosely attach the lower control arm to the control arm drop bracket with the 9/16" X 4" bolt, washer and nut from hardware pack 90-6276.  
**NOTE: Do not tighten the pivot bolts until the vehicle is at its new ride height. SEE ILLUSTRATION F.**
20. Repeat the control arm drop bracket installation on the remaining side of the vehicle.
21. Compress the new spring with a coil

spring compressor.

22. Continue to lower the differential until enough space exists to install the new Pro Comp springs, **PN 51021-4**.

**NOTE: If the factory spring has a rubber pad remove it and install it on to the new spring.**

23. You may have to release some slack in the differential vent hose by lightly pulling the excess down from the frame.
24. Repeat this procedure on the remaining side of the vehicle.
25. Install the rear shock extensions using **Illustration H** (Passenger side example) as a guide. Note that **PN 90-1680** is installed to the inside of the OE shock mount and **PN 90-1681** is installed outside of the OE shock mount. Ensure that the new springs are seated properly.
26. Reinstall the OE shocks to the new extension mount with the OE bolts and nuts.
27. Using **Illustration I** for reference, install the replacement ride height sen-

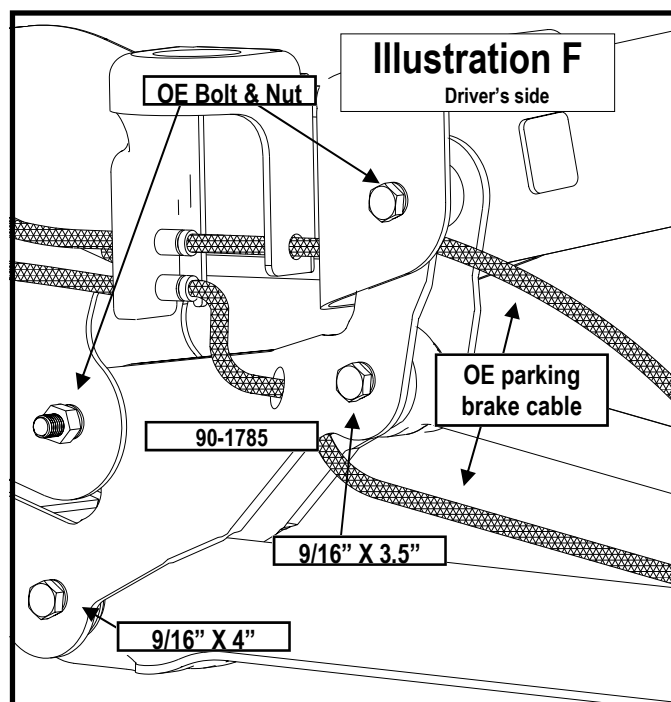

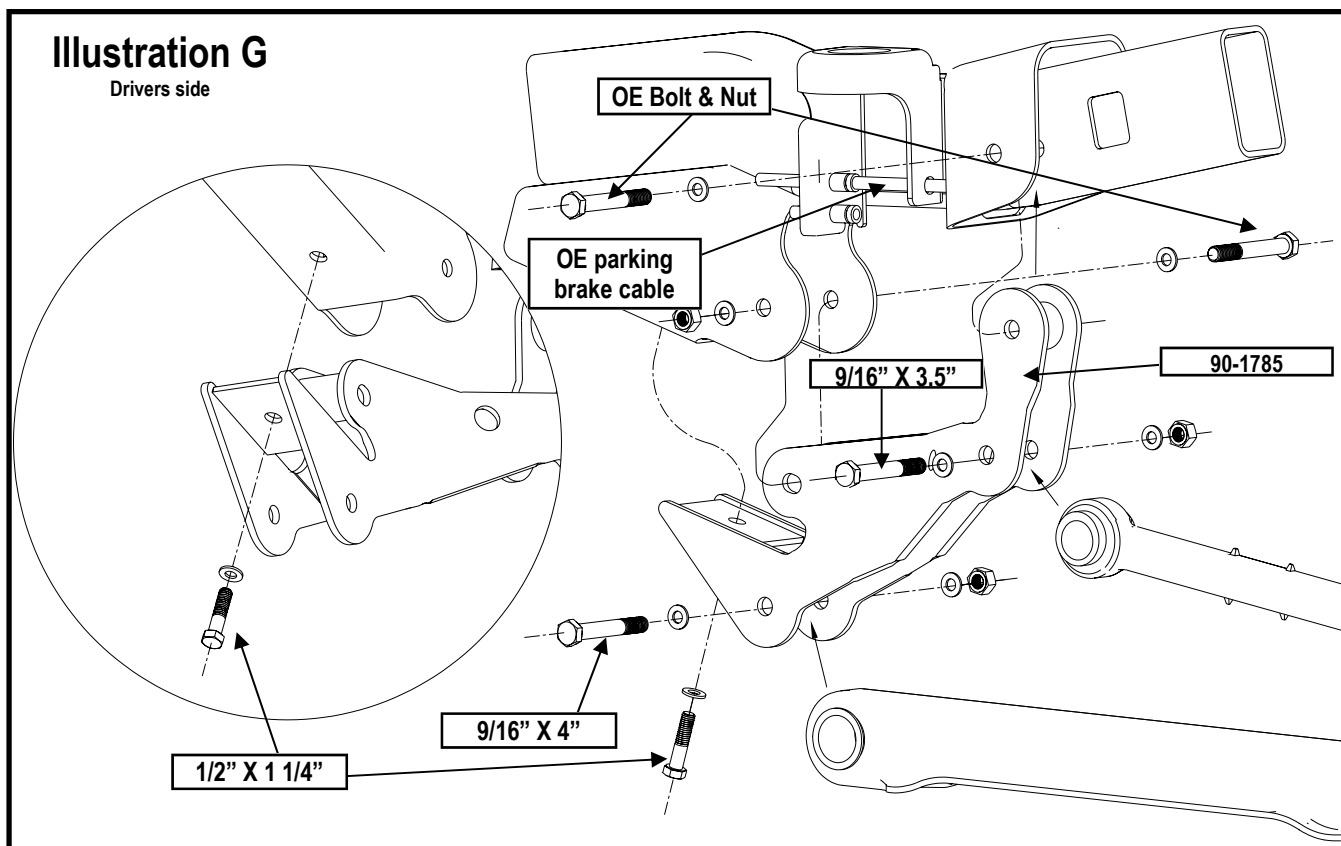

sor link (**PN 90-4060 (Short)**) to the OE mount locations.

**Notes:** **A) Be cautious with these sensors. Do not damage them or their wiring.**

**B) The lengths of the replacement links are preset at the factory. Do not change!**

28. Repeat this procedure on the remaining side of the vehicle.
29. Using the OE bolt, install the brake line relocation bracket (**PN 90-55089-4**) to the OE brake line mount position as shown in **Illustration A**. Bolt the OE bracket to the new relocation bracket using the **5/16" X 1"** bolt, nut, and washer provided.
30. Using **Illustration B** as a reference, install the track bar relocation adapter **PN 90-1682**. Place the adapter into the OE mount and use the OE bolt to hold it in place. On the passenger

On completion of the installation of your Explorer Pro Comp lift kit to your Chevrolet Tahoe / GMC Yukon, you will need to drive your vehicle for about 5 minutes for the Ride Control<sup>®</sup> system to have an opportunity to settle itself out. It is normal for the rear of the vehicle to seem a little low until this is done. The new ride control links provided are factory preset and should not be changed or modified.

If, however, you encounter a situation where the rear of your vehicle does not seem to be level or slightly higher than the front, call Pro Comp technical assistance. The number is on the cover page.

**Under no circumstances should the front ride control links be modified.**

side of the adapter are two holes that are used as drill guides for a 7/16" drill. Drill completely through the OE mount and install the 7/16" X 1 1/4" bolts, nuts, and washers provided. Torque these bolts to the bolt specifications in the rear of this manual.

31. Install the track bar into the newly installed adapter using the provided 9/16" X 3 1/2" bolt, nut and washer. Torque these bolts to the bolt specifications in the rear of this manual.

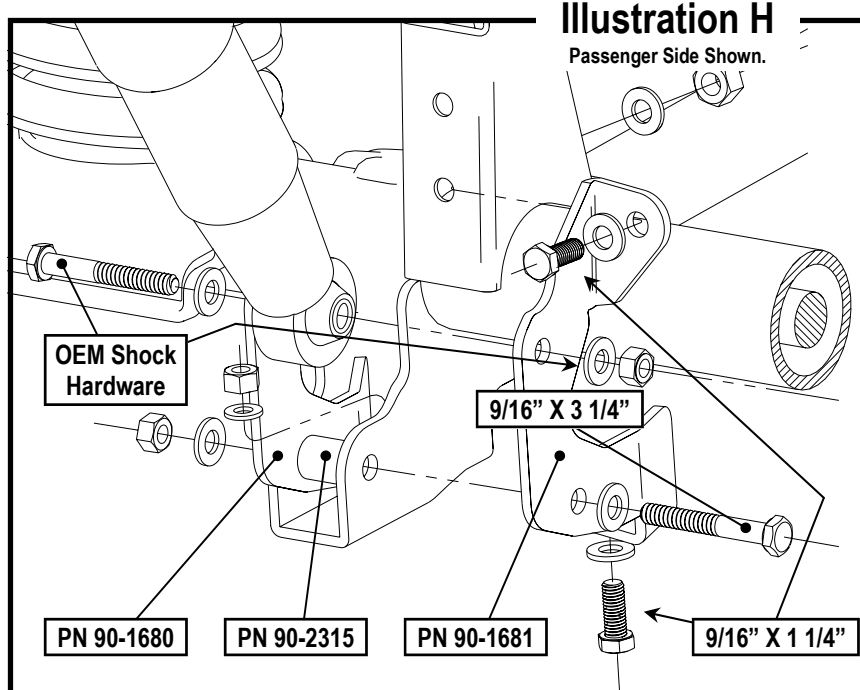

32. Install the sway bar using the new end links PN 90-2311. Use the bushings and sleeves from 90-6235. Use the OE bolt and nut on the top and use the hardware from pack P-843 on the bottom. Torque these bolts to the bolt specifications in the rear of this manual. **SEE ILLUSTRATION E.**

33. Torque all fasteners.
34. Install your wheels and tires, then lower the vehicle to the ground.
35. With the vehicle on the ground and Tighten control arm bolts to OE specifications.
36. After installation is complete, double check that all nuts and bolts in the front and rear are tight. Refer to the chart at the end of this document for torque specifications. Unless otherwise directed, use this chart for all torque specs.
37. Recheck for proper installation, then torque all newly installed hardware.
38. After 100 miles, recheck for proper torque on all newly installed hard-

ware.

39. Recheck all hardware for tightness after each off road use. ⚠

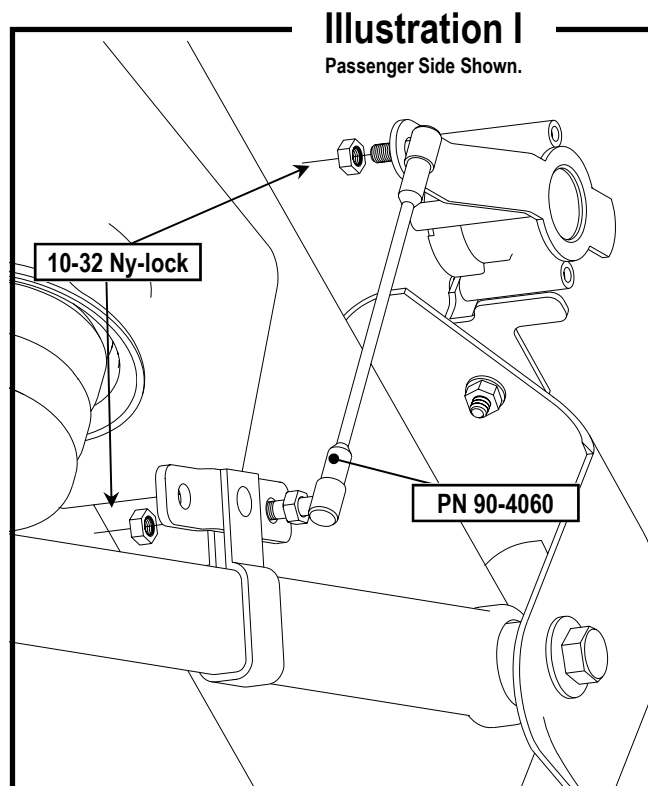

## Final notes:

1. If new tires are installed that are more than 10% taller than original tires, the speedometer must be recalibrated for the rear wheel anti-lock brake system to function properly. Contact an authorized GM dealer for details on recalibration.
2. With vehicle on the floor, cycle the steering from lock to lock and inspect the steering, suspension and driveline systems for proper operation, tightness and adequate clearance. Recheck brake hose/fittings for leaks. Be sure all brake lines are long enough for safe operation.
3. Have headlights readjusted to the proper settings.
4. Realign front end to factory specifications. Be sure the vehicle is at the desired ride height prior to realignment.
5. Recheck ALL fasteners at 100 miles to make sure they have not come loose. Due to the additional wear and tear created by larger tires and wheels, we recommend that you periodically check the suspension system and steering components to ensure service life and safe vehicle operation.

Use this only as a guide for hardware without a called out torque specification in the instruction manual.

<b>Bolt Torque and ID</b>						
<b>Decimal System</b>			<b>Metric System</b>			
All Torques in Ft. Lbs. Maximums						
Bolt Size	Grade 5	Grade 8	Bolt Size	Class 9.8	Class 10.9	Class 12.9
5/16	15	20	M6	5	9	12
3/8	30	45	M8	18	23	27
7/16	45	60	M10	32	45	50
1/2	65	90	M12	55	75	90
9/16	95	130	M14	85	120	145
5/8	135	175	M16	130	165	210
3/4	185	280	M18	170	240	290

1/2-13x1.75 HHCS    **Grade 5    Grade 8**  
(No. of Marks + 2)

D   T   L   X

G = Grade (Bolt Strength)  
D = Nominal Diameter (Inches)  
T = Thread Count (Threads per Inch)  
L = Length (Inches)  
X = Description (Hex Head Cap Screw)

M12-1.25x50 HHCS

D   T   L   X

P = Property Class (Bolt Strength)  
D = Nominal Diameter (Millimeters)  
T = Thread Pitch (Thread Width, mm)  
L = Length (Millimeters)  
X = Description (Hex Head Cap Screw)

**Notice to Owner operator, Dealer and Installer:**

Vehicles that have been enhanced for off-road performance often have unique handling characteristics due to the higher center of gravity and larger tires. This vehicle may handle, react and stop differently than many passenger cars or unmodified vehicles, both on and off-road. You must drive your vehicle safely! Extreme care should always be taken to prevent vehicle rollover or loss of control, which can result in serious injury or even death. Always avoid sudden sharp turns or abrupt maneuvers and allow more time and distance for braking! Pro Comp reminds you to fasten your seat belts at all times and reduce speed! We will gladly answer any questions concerning the design, function, maintenance and correct use of our products.

**Please make sure your Dealer/Installer explains and delivers all warning notices, warranty forms and instruction sheets included with Pro Comp product.**

Application listings in this catalog have been carefully fit checked for each model and year denoted. However, Pro Comp reserves the right to update as necessary, without notice, and will not be held responsible for misprints, changes or variations made by vehicle manufacturers. Please call when in question regarding new model year, vehicles not listed by specific body or chassis styles or vehicles not originally distributed in the USA.

**Please note that certain mechanical aspects of any suspension lift product may accelerate ordinary wear of original equipment components.** Further, installation of certain Pro Comp products may void the vehicle's factory warranty as it pertains to certain covered parts; it is the consumer's responsibility to check with their local dealer for warranty coverage before installation of the lift.

**Warranty and Return policy:**

Pro Comp warrants its full line of products to be free from defects in workmanship and materials. Pro Comp's obligation under this warranty is limited to repair or replacement, at Pro Comp's option, of the defective product. Any and all costs of removal, installation, freight or incidental or consequential damages are expressly excluded from this warranty. Pro Comp is not responsible for damages and / or warranty of other vehicle parts related or non-related to the installation of Pro Comp product. A consumer who makes the decision to modify his vehicle with aftermarket components of any kind will assume all risk and responsibility for potential damages incurred as a result of their chosen modifications. Warranty coverage does not include consumer opinions regarding ride comfort, fitment and design. Warranty claims can be made directly with Pro Comp or at any factory authorized Pro Comp dealer.

**IMPORTANT!** To validate the warranty on this purchase please be sure to mail in the warranty card.

**Claims not covered under warranty-**

- Parts subject to normal wear, this includes bushings, bump stops, ball joints, tie rod ends and heim joints
- Discontinued products at Pro Comp's discretion
- Bent or dented product
- Finish after 90 days
- Leaf or coil springs used without proper bump stops
- Light bulbs
- Products with evident damage caused by abrasion or contact with other items
- Damage caused as a result of not following recommendations or requirements called out in the installation manuals
- Products used in applications other than listed in Pro Comp's catalog
- Components or accessories used in conjunction with other manufacturer's systems
- Tire & Wheel Warranty as per Pro Competition Tire Company policy
- Warranty claims without "Proof of Purchase"
- Pro Comp Pro Runner coil over shocks are considered a serviceable shock with a one-year warranty against leakage only. Rebuild service and replacement parts will be available and sold separately by Pro Comp. Contact Pro Comp for specific service charges.
- Pro Comp accepts no responsibility for any altered product, improper installation, lack of or improper maintenance, or improper use of our products.

E-Mail: [tech@explorerprocomp.com](mailto:tech@explorerprocomp.com)  
Website: [www.explorerprocomp.com](http://www.explorerprocomp.com)  
Fax: (619) 216-1474  
Ph: (619) 216-1444

<b>PLACE</b> <b>WARRANTY REGISTRATION</b> <b>NUMBER</b> <b>HERE:</b> _____
---