

2360 Boswell Road
Chula Vista, CA 91914
Phone 619.216.1444
Fax 619.216.1474
E-Mail tech@explorerprocomp.com



PRO COMP SUSPENSION

Suspension Systems that Work!

**Part # 51024MX
2001-2003 2wd Tahoe/
Yukon/Yukon XL / Avalanche
5 Inch Lift Kit**

This document contains very important information that includes warranty information and instructions for resolving problems you may encounter. Please keep it in the vehicle as a permanent record.

Box 1 of 5-PN 51024MX-1

Part #	Description	Qty.	Illus.	Page
90-1761	FRONT CROSS MEMBER	1	2	6
90-1435	COMPRESSION STRUT MOUNTS	2	6	9
90-6227	HARDWARE PACK, CROSS MEMBER	1	4	7
70-0625001800	5/8" X 5" GR 8 HEX BOLT	2	4	7
70-0625501800	5/8" X 5 1/2" GR 8 HEX BOLT	2	4	7
72-062100816	5/8" USS GR 8 STOVER NUT	4	4	7
73-06200034	5/8" SAE GR 8 FLAT WASHERS	8	4	7
90-6262	HARDWARE PACK, CROSS MEMBER BRACES	1	2	6
70-0621501500	5/8" X 1 1/2" GR 5 HEX BOLT	2	2	6
72-062100512	5/8" USS GR 5 NYLOCK NUT	2	2	6
73-06200034	5/8" SAE GR 8 FLAT WASHERS	4	2	6
72-056100512	9/16" USS GR 5 NYLOCK NUT	2	2	6
73-05600034	9/16" SAE GR 8 FLAT WASHER	2	2	6
90-6263	HARDWARE PACK, BUSHINGS AND SLEEVES	1	6	9
15-11148	COMPRESSION STRUT BUSHING	8	6	9
90-2109	SLEEVE, COMPRESSION STRUT - 2.75"	4	6	9
90-6264	HARDWARE PACK, LOW-PROFILE BUMPSTOP	1	3	7
15-11018	LOW-PROFILE BUMPSTOP	2	3	7
72-037100512	3/8" GR 5 NYLOCK NUT	2	3	7
73-03700530	3/8" GR 5 FLAT WASHER	2	3	7
90-6272	HARDWARE PACK, SWAY BAR LINKS	1	5	8
90-1476	NUT PLATE - 1/2"	2	6	9
90-2329	SPACER .625" X .120" WALL X 9.50"	2	5	8
13-90420	3/8"-24 X 14-1/2" THD. ROD	2	5	8
72-037200510	3/8"-24 SAE GRADE 5 HEXNUT	4	5	8
P438	STEM PACK	4	5	8
90-6177	HARDWARE PACK, TORSION DROP BUSHINGS	1	7	10
90-2011	SPACER, 1" X .05" X 1 1/2"	2	7	10
15-11149	BUSHING, URETHANE	4	7	10
90-6181	HARDWARE PACK, SHOCK ADAPTER	1		
90-1079	SHOCK ADAPTER	2		
70-0502751500	1/2" X 2 3/4" GR 5 HEX BOLT	2		
72-05000100512	1/2" USS GR 5 NYLOCK NUT	2		
72-06200100512	5/8" USS GR 5 NYLOCK NUT	2		
73-06200032	5/8" USS BR 5 FLAT WASHER	2		
54314	SHOCK SLEEVE, 1/2" X 5/8" X 1"	2		
90-1785	REAR CONTROL ARM DROP BRACKET DRIVER	1		
90-1790	REAR CONTROL ARM DROP BRACKET PASSENGER	1		
90-6276	HARDWARE PACK, REAR CONTROL ARM DROP BRACKET	1	G	14
70-0563501800	9/16"-12 X 3.5" GR 8 HEXBOLT	2		
70-0564001800	9/16"-12 X 4" GR 8 HEXBOLT	2		
72-056100816	9/16"-12 GR 8 STOVER NUT	4		
73-05600034	9/16" SAE HARDENED WASHER	8		
70-0501251800	1/2" X 1 1/4" GR 8 HEX BOLT	2		
72-050100816	1/2" GR 8 STOVER NUT	2		
73-05000034	1/2" GR 8 FLAT WASHER	4		

Optional Equipment Available from your Pro Comp Distributor!

Skid Plate

PN 51199

Also, check out our outstanding selection of Pro Comp tires to compliment your new installation!

Part #	Description	Qty.	Illus.	Page
Box 2 of 5-PN 51024MX-2				
90-4078	SPINDLE, DRIVER SIDE	1		
90-4079	SPINDLE, PASSENGER SIDE	1		

Box 3 of 5-PN 51024MX-3

90-1740	REAR CROSS MEMBER	1	2	6
90-2333	CROSS MEMBER BRACE, DRIVER	1	2	6
90-2334	CROSS MEMBER BRACE, PASSENGER	1	2	6
90-2126	COMPRESSION STRUT	2	6	9
90-1606	TORSION DROP BRACKET	2	7	10
90-1682	TRACK BAR RELOCATION BRACKET	1	B	11
90-2311	SWAY BAR EXTENSIONS	2	E	13
90-6244	HARDWARE PACK, BUMPSTOP	1		
90-3146	BUMP STOP PLATE	4	C	12
90-1702	NUT PLATE	2	C	12
70-0371001800	3/8" X 1" GR 8 HEX BOLT	4	C	12
73-03700836	3/8" GR 8 SPLIT WASHER	4	C	12
90-6234	HARDWARE PACK, COMPRESSION STRUT	1	6	9
70-0501251800	1/2" X 1 1/4" GR 8 HEX BOLT	2	6	9
70-0504001800	1/2" X 4" GR 8 HEX BOLT	4	6	9
72-050100816	1/2" GR 8 STOVER NUT	4	6	9
73-05000034	1/2" GR 8 FLAT WASHER	10	6	9
90-6236	HARDWARE PACK, TRACK BAR AND TORSION	1		
70-0563501800	9/16-12 X 3 1/2" GR 8 HEXBOLT	1	B	11
70-0563001800	9/16-12 X 3" GR 8 HEXBOLT	2	7	10
72-056100816	9/16-12 GR 8 STOVER NUT	3	7	10
73-05600034	9/16 SAE HARDENED WASHER	6	7	10
70-0431251800	7/16-14 X 1 1/4" GR 8 HEXBOLT	2	B	11
72-043100816	7/16-14 GR 8 STOVER NUT	2	B	11
73-04300034	7/16 SAE HARDENED WASHER	4	B	11
70-0311001800	5/16-18 X 1" GR 8 HEXBOLT	1	A	11
72-031100816	5/16-18 GR 8 STOVER NUT	1	A	11
73-03100034	5/16 SAE HARDENED WASHER	2	A	11
90-6235	HARDWARE PACK, REAR SWAY BAR / BRAKE LINE	1	E	13
P-843	SHOCK HARDWARE	2	E	13
60859H	SHOCK SLEEVE	2		
45359	BUSHING, 5/8" "HOURLASS", URETHANE	4		
90-55089-4	REAR BRAKELINE EXTENSION	1	A	11

Box 4 of 5-PN 51024MX-4

14121-1	REAR COIL SPRINGS	2		
---------	-------------------	---	--	--

Box 5 of 5-PN 51024MX-5

MX6019	SHOCKS, FRONT	2		
MX6098	SHOCKS, REAR	2		

Special Equipment

A special removal tool is required for safe removal and installation of the torsion adjuster arms. This special puller can be purchased from your local GM dealer (Tool #J36202) or from the Kent Moore Tool Group in Roseville, MI. (800) 345-2233 or (313) 774-9500 (Part #J22517-C). Please refer to your GM service manual for more information.

A special removal tool is required for safe removal of the tie rods. (Tie rod puller # J6627-A). A special removal tool is required for safe removal of the ball joints. (Ball joint separator tool # J23742). A special removal tool is required for safe removal of the coil springs. (Coil spring removal and installation tool # J23028-A) These tool may be purchased at your local GM dealer. You may be able to rent these at your local parts store.

Introduction:

- ◆ **This installation requires a professional mechanic!**
- ◆ We recommend that you have access to a GM service manual for your vehicle to assist in the disassembly and reassembly of your vehicle. It contains a wealth of detailed information.
- ◆ Prior to installation, carefully inspect the vehicle's steering and driveline systems paying close attention to the tie rod ends, ball joints, wheel bearing preload, pitman and idler arm. Additionally, check steering-to-frame and suspension-to-frame attaching points for stress cracks. The overall vehicle must be in excellent working condition. Repair or replace all worn or damaged parts!
- ◆ Read the instructions carefully and study the illustrations before attempting installation! You may save yourself a lot of extra work.
- ◆ Check the parts and hardware against the parts list to assure that your kit is complete. Separating parts according to the areas where they will be used and placing the hardware with the brackets before you begin will save installation time.
- ◆ Check the special equipment list and ensure the availability of these tools.
- ◆ Secure and properly block vehicle prior to beginning installation.
- ◆ ***ALWAYS*** wear safety glasses when using power tools or working under the vehicle!
- ◆ Use caution when cutting is required under the vehicle. The factory undercoating is flammable. Take appropriate precautions. Have a fire extinguisher close at hand.
- ◆ Foot pound torque readings are listed on the Torque Specifications chart at the end of the instructions. These are to be used unless specifically directed otherwise. Apply thread retaining compound where specified.
- ◆ ***Please note that while every effort is made to ensure that the installation of your Pro Comp lift kit is a positive experience, variations in construction and assembly in the vehicle manufacturing process will virtually ensure that some parts may seem difficult to install. Additionally, the current trend in manufacturing of vehicles results in a frame that is highly flexible and may shift slightly on disassembly prior to installation. The use of pry bars and tapered punches for alignment is considered normal and usually does not indicate a faulty product. However, if you are uncertain about some aspect of the installation process, please feel free to call our tech support department at the number listed on the cover page. We do not recommend that you modify the Pro Comp parts in any way as this will void any warranty expressed or implied by the Pro Comp Suspension company.***

Please Note:

- ⇒ Front end and head light realignment is necessary!
- ⇒ Speedometer and ABS recalibration will be necessary if larger tires (10% more than stock diameter) are installed.
- ⇒ Due to differences in manufacturing, dimensions and inflated measurements, tire and wheel combinations should be test fit prior to installation. Tire and wheel choice is crucial in assuring proper fit, performance, and the safety of your Pro Comp equipped vehicle. For this application, we recommend a wheel not to exceed 8" in width with a minimum backspacing of 4" must be used, additionally, a quality tire of radial design, not exceeding 35" tall X 12.5" wide is also recommended. Please note that the use of a 35" X 12.5" tire may require fender modification. Violation of these recommendations will not be endorsed as acceptable by Pro Comp Suspension and will void any and all warranties either written or implied.

1. Ensure that your work space is of adequate size and the work surface is level. Place the vehicle in neutral. Place your floor jack under the front cross member and raise vehicle. Place jack stands under the frame rails behind the front wheel wells and lower the frame onto the stands. Remove the jack and place the vehicle back in gear, set the emergency brake, and place blocks both in front and behind the rear wheels.

2. Measure and record the distance from the center of each wheel to the top of its fender opening.

LF: _____ RF: _____

LR: _____ RR: _____

3. Remove any skid plates or debris shields from the vehicle.
4. Measure the torsion bar adjusting screw depth and record this dimension for later use on re-assembly. See **Illustration 1**.

LEFT: _____ RIGHT: _____

5. **Warning! Be extremely careful when unloading or loading the torsion bars on your vehicle. There is a tremendous amount of stored energy! Keep your hands and body clear of the adjuster arm assembly and puller tool in case anything slips or breaks!**
6. Mark the torsion bars orientation for later re-installation. Apply a small amount of lubrication grease to the puller threads and the puller shaft-to-adjuster arm contact point. Load the puller and torsion adjuster arm until the adjuster nut can be removed from the cross member. Remove the torsion bar adjusting screw. Release the puller to unload the torsion bar. With the bar unloaded, slide it forward into the lower control arm until the adjuster arm falls free.

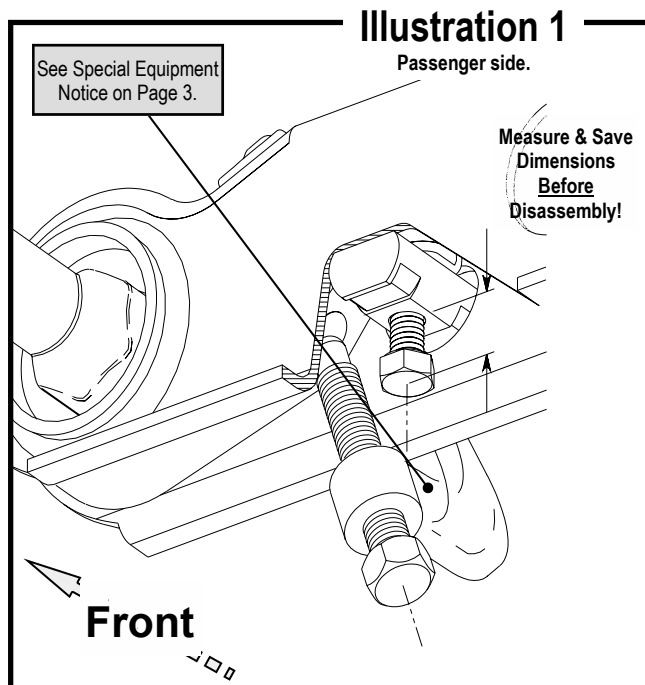

Note: If the bar seems stuck, use a hammer and punch through the hole in the rear of the cross member to dislodge it.

7. Repeat this procedure on the other side of the vehicle.
8. Remove the torsion bars from the lower A-arms.
9. Remove the torsion bar cross member by unbolting it from the frame.
10. If you have a steering damper mounted, remove it from the vehicle.
11. Remove the sway bar end links.
12. Remove the front shock absorbers.

Work on one side of the vehicle at a time.

13. Remove the nut from the OE tie rod end. Using an appropriate removal tool, remove the tie rod end from the spindle.
14. Remove the brake calipers from the rotor and secure them clear of the work area. Secure calipers up with wire so they do not hang.

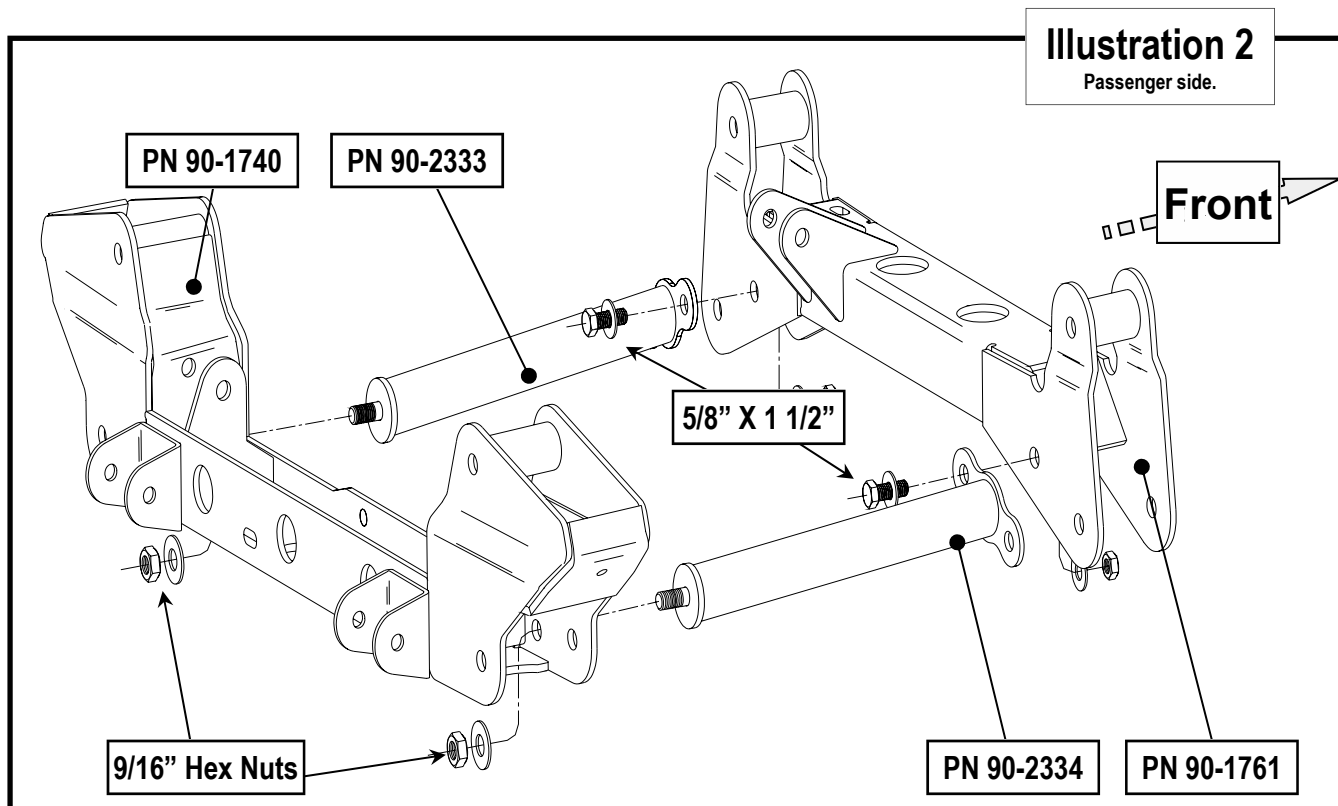

Caution: Do not suspend them by the brake lines! Damage will result!

15. If your vehicle is equipped with ABS brakes, disconnect the wiring from the vehicle wire loom and any wiring clamps located on the frame.
16. Support the lower A-arm assembly with your floor jack and remove the upper and lower ball joint nuts and remove the spindle from the vehicle using the tools recommended in your GM service manual.
17. Remove the lower A-arm pivot bolts. Carefully remove the lower A-arms from the vehicle. ⚠
18. Assemble the front cross member (PN 90-1761), rear cross member (PN 90-1740), and cross member braces (PN's 90-2333 & 90-2334) on your work bench. Use hardware pack 90-6262. Use **Illustration 2** as a guide. Leave all these fasteners loose for the moment.
19. Install the urethane bump stops (PN 15-11018) from hardware pack 90-6264, onto the rear cross member as shown in **Illustration 3**.
20. Support the entire drop assembly on your floor jack.

Note: Use a section of 1/2" plywood on your jack to assist in maintaining control of this assembly.
21. Move the assembly into position under your vehicle and carefully raise it into the OE lower A-arm mounts. Use the OE hardware to locate and attach the assembly to the frame. Again leave the fasteners loose.
22. Install the lower A-arms into the new drops using the 5/8" X 5" bolts in the front and the 5/8" X 5 1/5" bolts in the rear. This hardware can be found in hardware pack 90-6227. Make sure the 5" bolts pass through the cross member brace flanges on both sides of the vehicle. See **Illustration 4**.
23. Apply pressure to the cradle assembly with your floor jack to fully seat it into the mounts. Torque the upper mount bolts to 107 ft-lbs **DO NOT** torque the lower A-arm pivot bolts

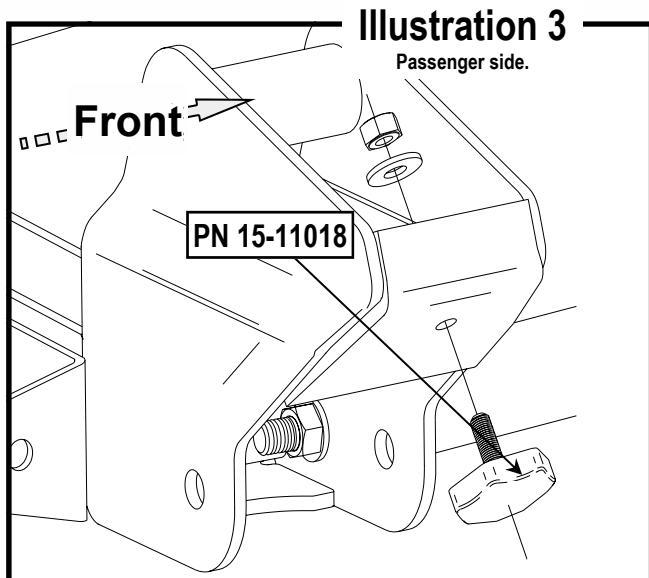

at this time.

24. Disassemble the OE spindles on your work bench. Remove the metric fasteners from the rear of the spindle and remove the bearing cartridge and dust shield.

Note: Be very careful with the ABS sensor and wire loom that is attached to the bearing cartridge.

25. Reassemble the dust cover and bearing cartridge into the new steering knuckle (PN's **90-4078 Driver, 90-4079 Passenger**). Make sure that the ABS wiring is oriented in exactly the same position as it came from the OE knuckle.

Important: Now would be an excellent time to make sure the bearing is in good condition.

Torque the bearing to the knuckle with the OE bolts. Torque to 133 ft-lbs

26. Install the assembled knuckle to the upper and lower ball joints using the OE hardware. Torque the upper ball joint to 37 ft-lbs and the lower ball joint to 74 ft-lbs

27. Loosen the tie rod end jam nut and thread the tie rod end inward two complete turns. Re-tighten the jam nut and attach the tie rod end to the new knuckle. Torque the factory nut to 33 ft-lbs

28. Repeat on the other side. ⚙
29. Reinstall the disk brake rotors and calipers and torque the calipers to the knuckle to 129 ft-lbs Using a drift or large screwdriver through the caliper, hold the disk firmly. Torque the hardware to specifications. ⚙
30. Slide the brake hose clamp down and attach it to the top hole in the back of the steering knuckle. Use a clamp bolt from the original knuckle.
31. Repeat on the other side. ⚙
32. If you have ABS brakes, attach the ABS cable to the knuckle and upper control arm with zip ties.
33. Use the new hardware from pack **90-6272** to assemble the sway bar linkage. Start by threading one of the lock-nuts onto one end of the threaded rod (**PN 13-90420**) while holding the threaded rod in your bench vise.
34. Install the sway bar end links and torque to specs. See **Illustration 5**.

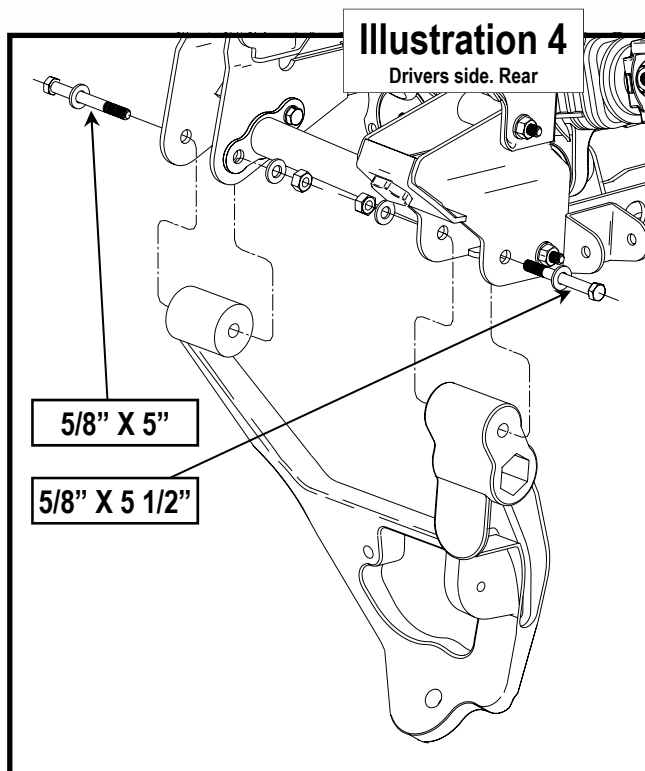

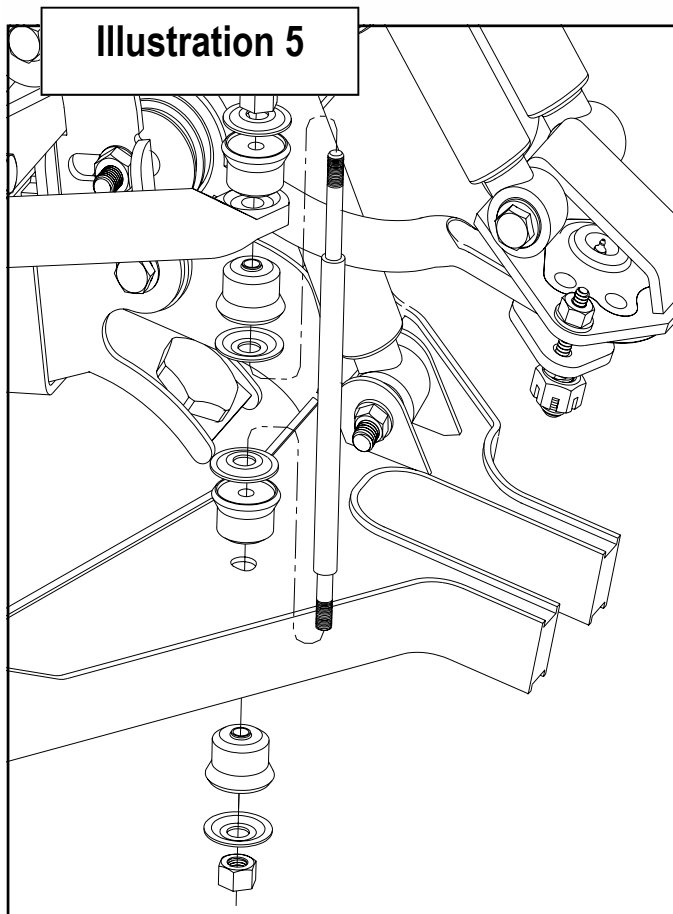

35. Repeat on the other side. ⚙
36. Install the new Pro Comp shock absorbers (PN MX6019) to the front installation. ⚙
37. Assemble the compression strut assemblies as shown in **Illustration 6**. Use the urethane bushings (PN 15-11148) and sleeves (PN 90-2109) from parts pack 90-6263.
38. The compression struts are next. One end is welded at an angle. Install this end into the mounts on the A-arm cross member with the strut angled out toward the frame. Use one of the 1/2" X 4" bolts supplied in hardware pack 90-6234 through each front mount and strut. Use **Illustration 6** for a reference.
39. Swing the compression strut up and to the rear until it is near the transmission cross member. Hold one of the compression strut mounts (PN 90-1435) in place and rotate it until one of the holes is lined up between the strut mount and an existing hole in the cross member and at the same time is lined up with the compression strut sleeve. Insert one of the 1/2" X 1 1/4" bolts from hardware pack 90-6234 through the mount and frame. Install one of the nut plates (PN 90-1476) over the bolt and snug up the bolt. Install another 1/2" X 4" bolt through the compression strut mount and end as shown in **Illustration 6**. Repeat this procedure for the remaining side. Torque the compression strut hardware to spec. ⚙
40. Install the torsion bar cross member drops by locating the new parts (PN 90-1606) in place as shown in **Illustration 7**. Use the supplied 9/16" X 3" bolts at the top and the OE fastener at the bottom.
41. Install the OE cross member to the drops using the OE bolts.
Note: The weld nuts on the cross member are oriented to the rear.
42. Install the Torsion bars by reversing the order in which they were removed. Again, be very careful to install them with the same orientation that they were removed (i.e., left front to left front, right front to right front). Reset the preload bolts to the same measurements previously taken in **Instruction #2**.
43. With the truck still on jack stands and the suspension hanging at full extension, cycle the steering from lock to lock to check that all components have clearance and operate freely. Pay very close attention to the ABS wiring and brake lines.
44. Reinstall your wheels and tires and properly torque the lug nuts to factory specs. Again check all areas around the suspension and tires for clearance issues.
45. Lower the truck to the ground to preload the suspension and unload the upper A- arms.
46. Tighten the lower A-arm pivot bolts to specifications. It is necessary to rotate the upper A-arm alignment cam bolts to a neutral position (in the center of the alignment slot) and then tighten the cam bolts to specifications. This

step is necessary to allow you to get to a professional alignment shop only! Do not assume that this setting is “close enough” and skip the alignment!

- 47. Recheck for proper installation and torque, all newly installed hardware.
- 48. After 100 miles recheck for proper torque on

all newly installed hardware.

- 49. Have your headlights adjusted.
- 50. Recheck all hardware for tightness after off road use. ⚠

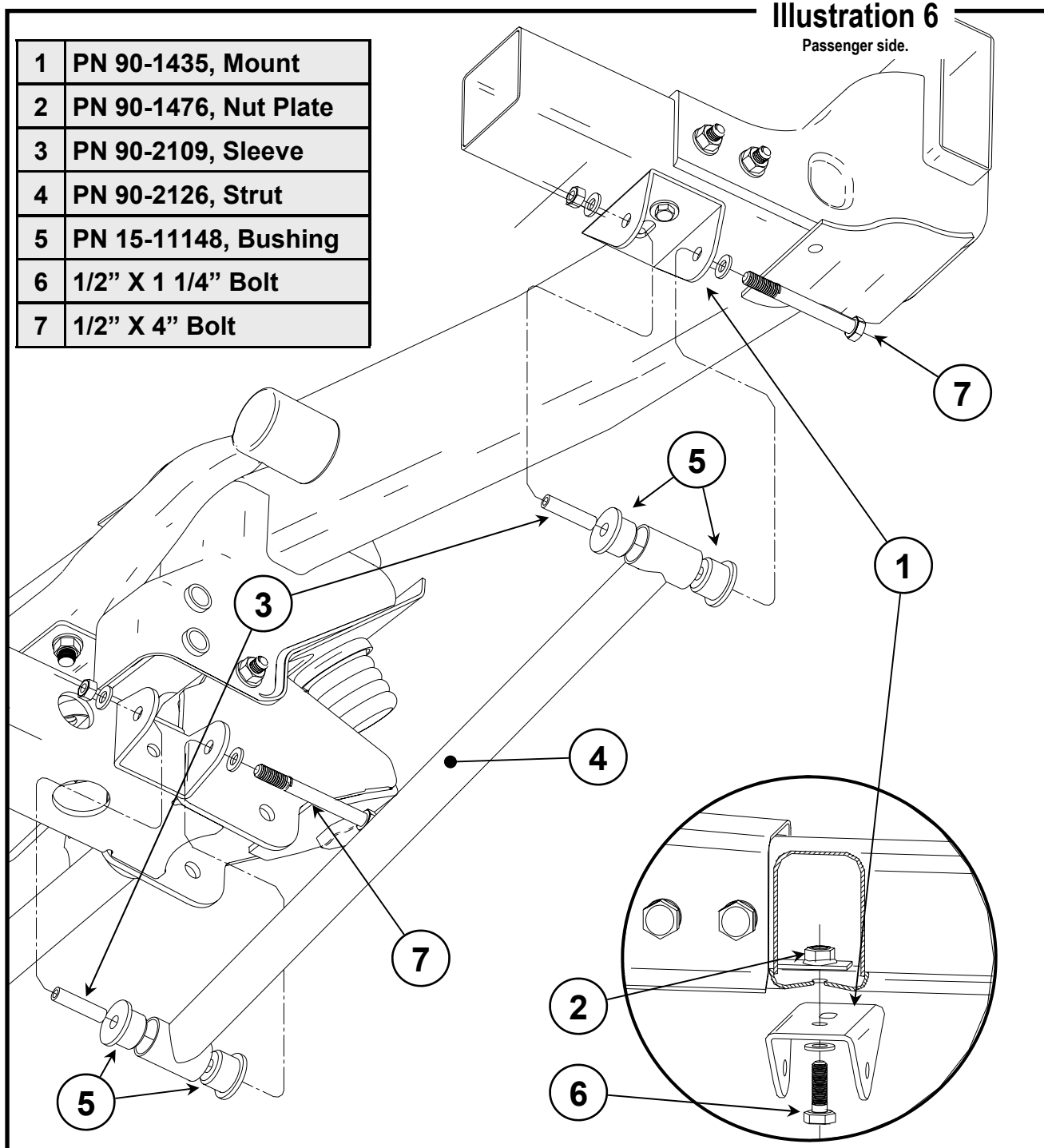
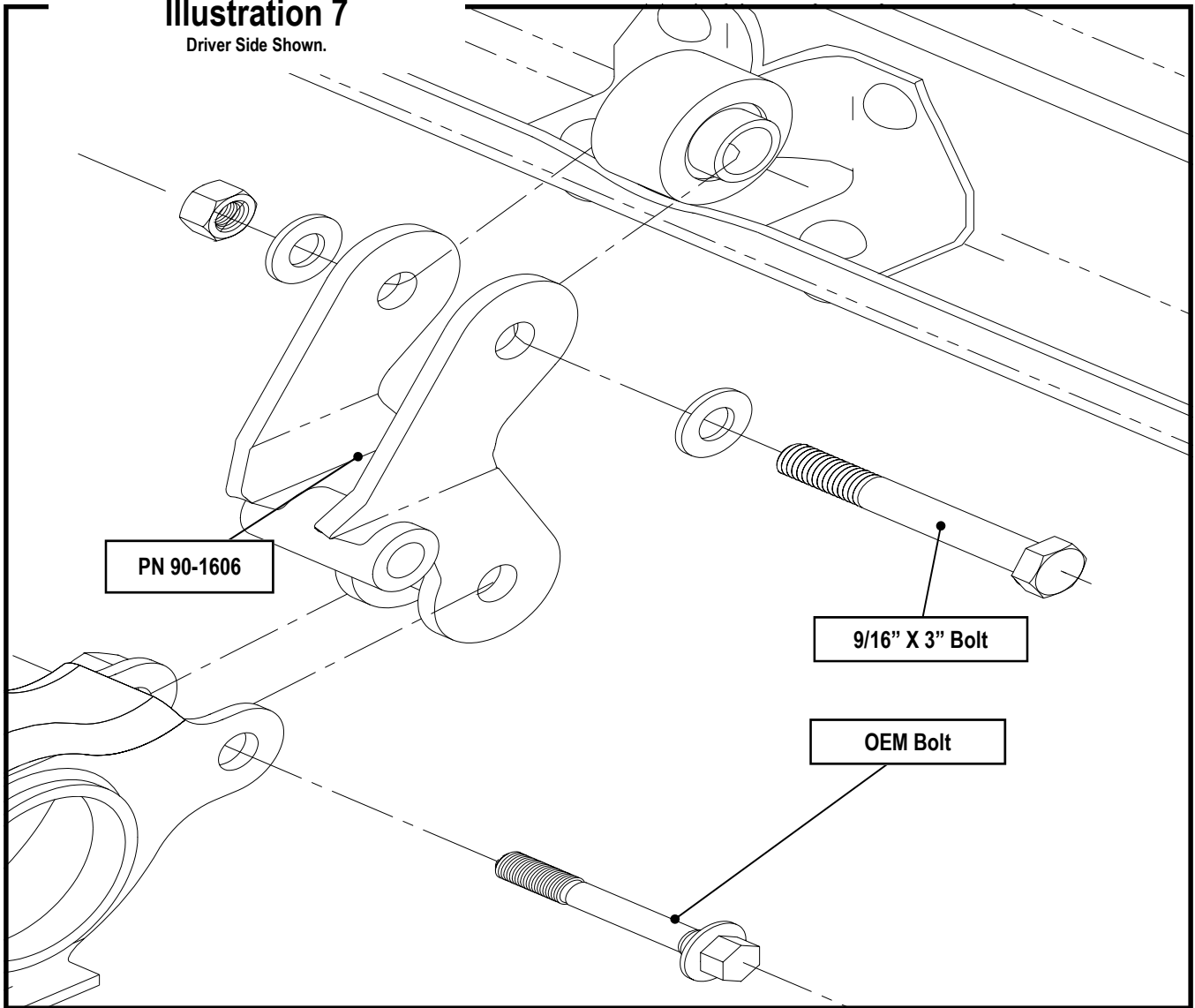

Illustration 7
Driver Side Shown.



Rear kit installation

1. Raise the rear of the vehicle enough for the tires to clear the ground and use jack stands on the frame to support the truck. Remove the rear tires and wheels.
2. Support the differential with your floor jack and remove the OEM shock absorbers. It may be necessary to raise the differential housing slightly to facilitate their removal.
3. Completely remove the sway bar links from both ends of the sway bar. Save the fasteners.
4. Remove the OE bolts from the differential track bar at the upper track bar mount. Save this hardware.
5. Remove the brake line mount bolt at the upper front location of the vehicle gas tank. See **Illustration A**.

6. Carefully lower the differential away from the vehicle and remove the stock springs.

Important: Be very careful not to damage the brake lines! Remove mounting brackets as needed to allow the brake lines freedom of movement sufficient to avoid damage. Remember to reinstall them when done.

7. At the OE bump stop, measure from the center of the existing hole at the rear 2.800 inches

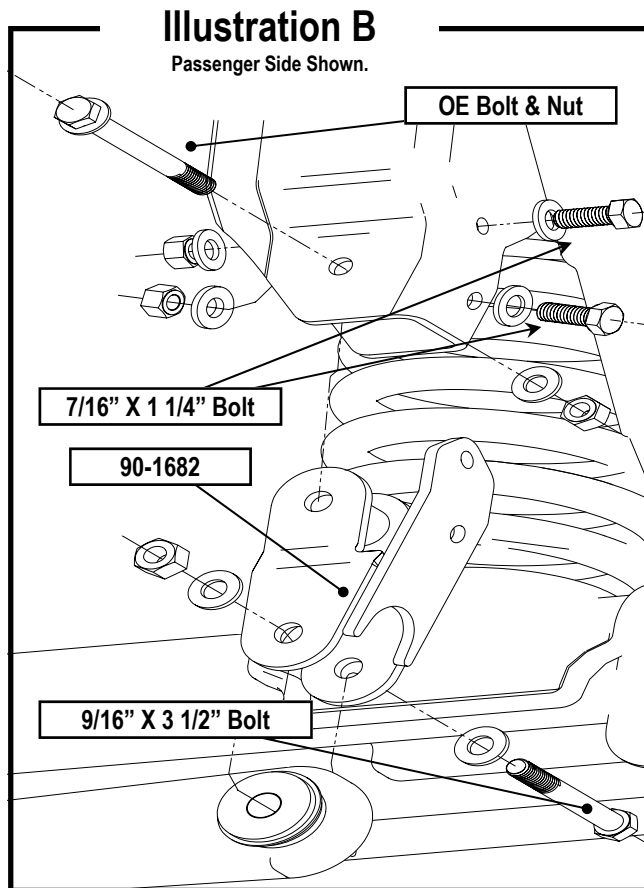
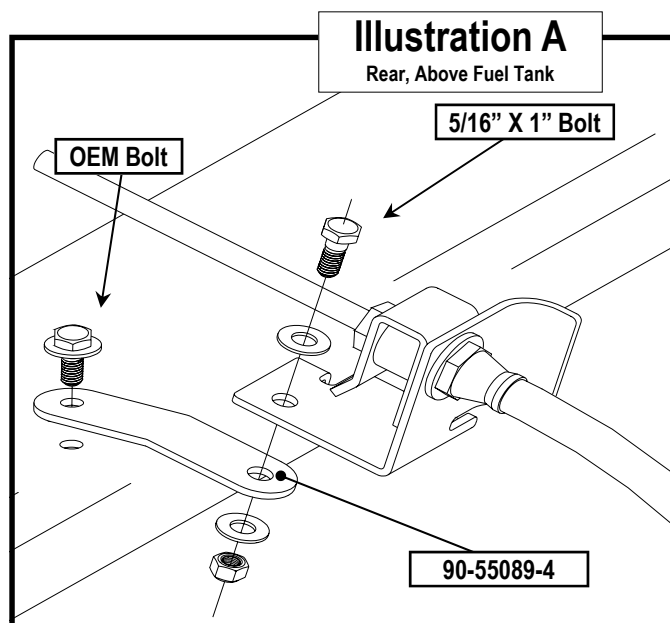

toward the front of the vehicle and carefully mark and center punch this location. Keep the center line between the two holes, parallel to the vehicle center line. Drill through this location with a 1/2" drill bit. See **Illustration C**.

8. Using **Illustration C** as a guide, install the bump stop extension plates (PN 90-3146) to the existing bump stop by first installing one 3/8" X 1" bolt and lock washer through one of the holes in the bump stop extension plates. Slide the nut plate (PN 90-1702) between the OE bump stop and the lower trailing arm until the back nut lines up with the hole in the OE bump stop. Take the bump stop extension with its bolt and place it on top of the pad and start the bolt into the nut plate. Rotate the nut plate to the location of the previously drilled front hole and start the second 3/8" X 1" bolt

Illustration C

Passenger Side Shown.

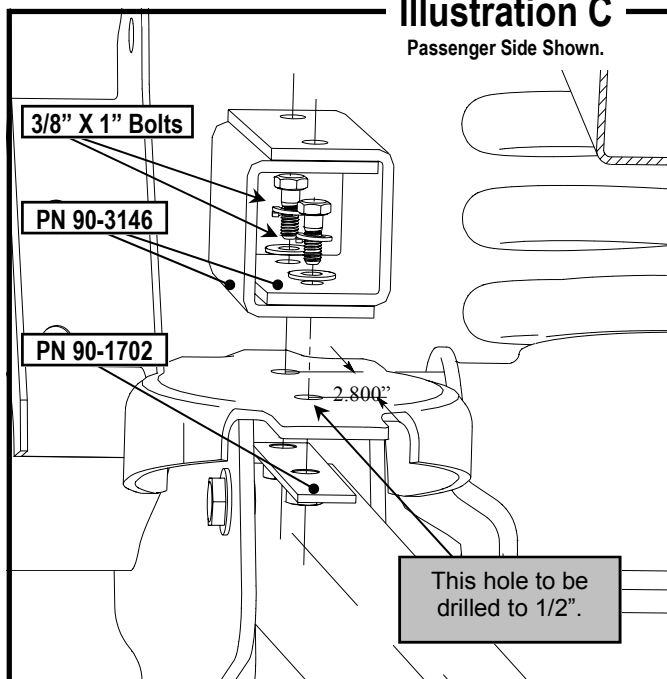

with lock washer into the remaining nut on the nut plate. Tighten these bolts to 45 ft-lbs

9. Repeat this procedure on the remaining side of the vehicle. ⚙

10. On the rear of the drivers side frame rail, loosen and disconnect the parking brake adjuster cable connector and nut. Compress the retaining fingers on the rear cables and pull the parking break cables away from the frame.

NOTE: Mark the upper and lower cables so they can be put back in the same orientation.

11. Remove the nuts and bolts attaching the upper and lower rear control arms on the driver's side of the frame. Do not remove the control arms from the passenger side .
12. Loosen the bolt attaching the lower control arm to the axle bracket. Allow the lower control arm to hang downward.
13. Attach the control arm drop bracket (DRIVER'S PN 90-1785 and PASSENGER PN 90-1790) to the frame using the original bolts. **SEE ILLUSTRATION G.**
14. Drill a 1/2" hole through the bottom of the

lower frame bracket hole and the frame. Install the 1/2" hardware from hardware pack 90-6276.

15. Tighten the 1/2" nut and bolt to 65 ft-lbs and the original bolts to 80 ft-lbs.
16. Pull the parking brake cables through the new control arm drop bracket, the top cable through the bracket and the bottom cable through the hole in the side of the bracket. Connect the parking brake cable connector and nut. Adjust parking brake tension to factory specifications.
17. Loosely attach the upper control arm to the control arm drop bracket with the 9/16" X 3.5" bolt, washer and nut from hardware pack 90-6276.

NOTE: Do not tighten the pivot bolts until the vehicle is at its new ride height.

18. Loosely attach the lower control arm to the control arm drop bracket with the 9/16" X 4" bolt, washer and nut from hardware pack 90-6276.

NOTE: Do not tighten the pivot bolts until the vehicle is at its new ride height. **SEE ILLUSTRATION F.**

19. Repeat the control arm drop bracket installation on the remaining side of the vehicle. ⚙
20. Compress the new spring with a coil spring

Illustration D

Finished View Shown.

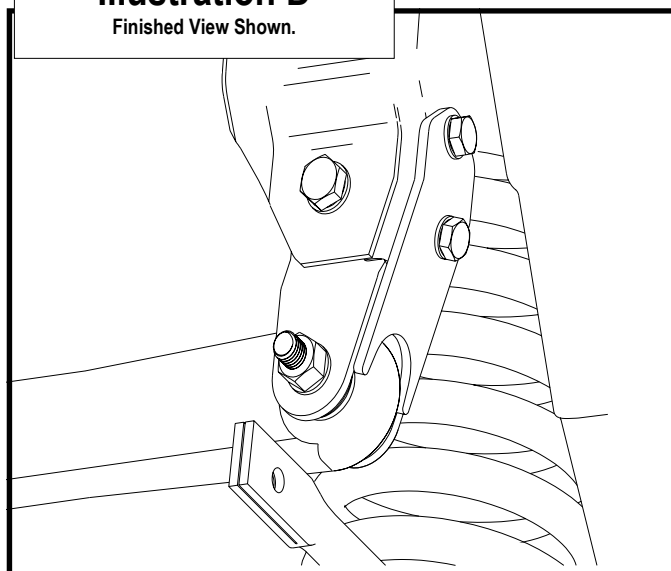

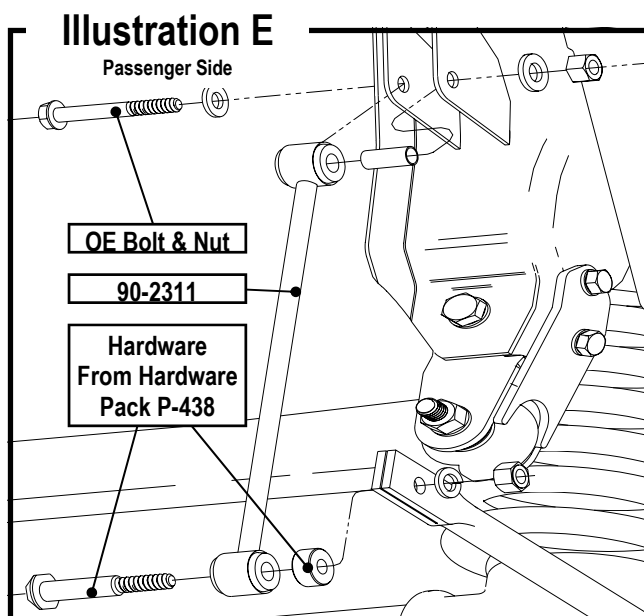

compressor.

21. Continue to lower the differential until enough space exists to install the new Pro Comp springs, **PN 51021-4**.
NOTE: *If the factory spring has a rubber pad remove it and install it on to the new spring.*
22. You may have to release some slack in the differential vent hose by lightly pulling the excess down from the frame.
23. Repeat this procedure on the remaining side of the vehicle. ☘
24. Raise the rear end until the new Pro Comp shock absorbers, **MX6098**, can be installed. Ensure that the new springs are seated properly.
25. Using the OE bolt, install the brake line relocation bracket (**PN 90-55089-4**) to the OE brake line mount position as shown in **Illustration A**. Bolt the OE bracket to the new relocation bracket using the **5/16" X 1"** bolt, nut, and washer provided.
26. Using **Illustration B** as a reference, install the track bar relocation adapter **PN 90-1682**. Place the adapter into the OE mount and use the OE bolt to hold it in place. On the passenger side of the adapter are two holes that are used as drill guides for a **7/16"** drill. Drill completely through the

OE mount and install the **7/16" X 1 1/4"** bolts, nuts, and washers provided. Torque these bolts to the bolt specifications in the rear of this manual.

27. Install the track bar into the newly installed adapter using the provided **9/16" X 3 1/2"** bolt, nut and washer. Torque these bolts to the bolt specifications in the rear of this manual.
28. Install the sway bar using the new end links **PN 90-2311**. Use the bushings and sleeves from **90-6235**. Use the OE bolt and nut on the top and use the hardware from pack **P-843** on the bottom. Torque these bolts to the bolt specifications in the rear of this manual. **SEE ILLUSTRATION E.**
29. Torque all fasteners.
30. Install your wheels and tires, then lower the vehicle to the ground.
31. With the vehicle on the ground and Tighten control arm bolts to OE specifications.
32. After installation is complete, double check that all nuts and bolts in the front and rear are tight. Refer to the chart at the end of this document for torque specifications. Unless otherwise directed, use this chart for all

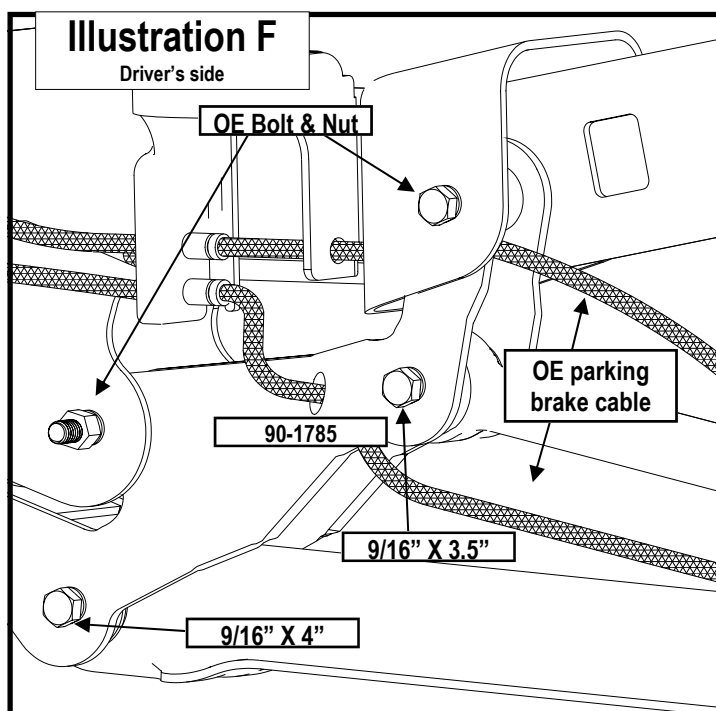

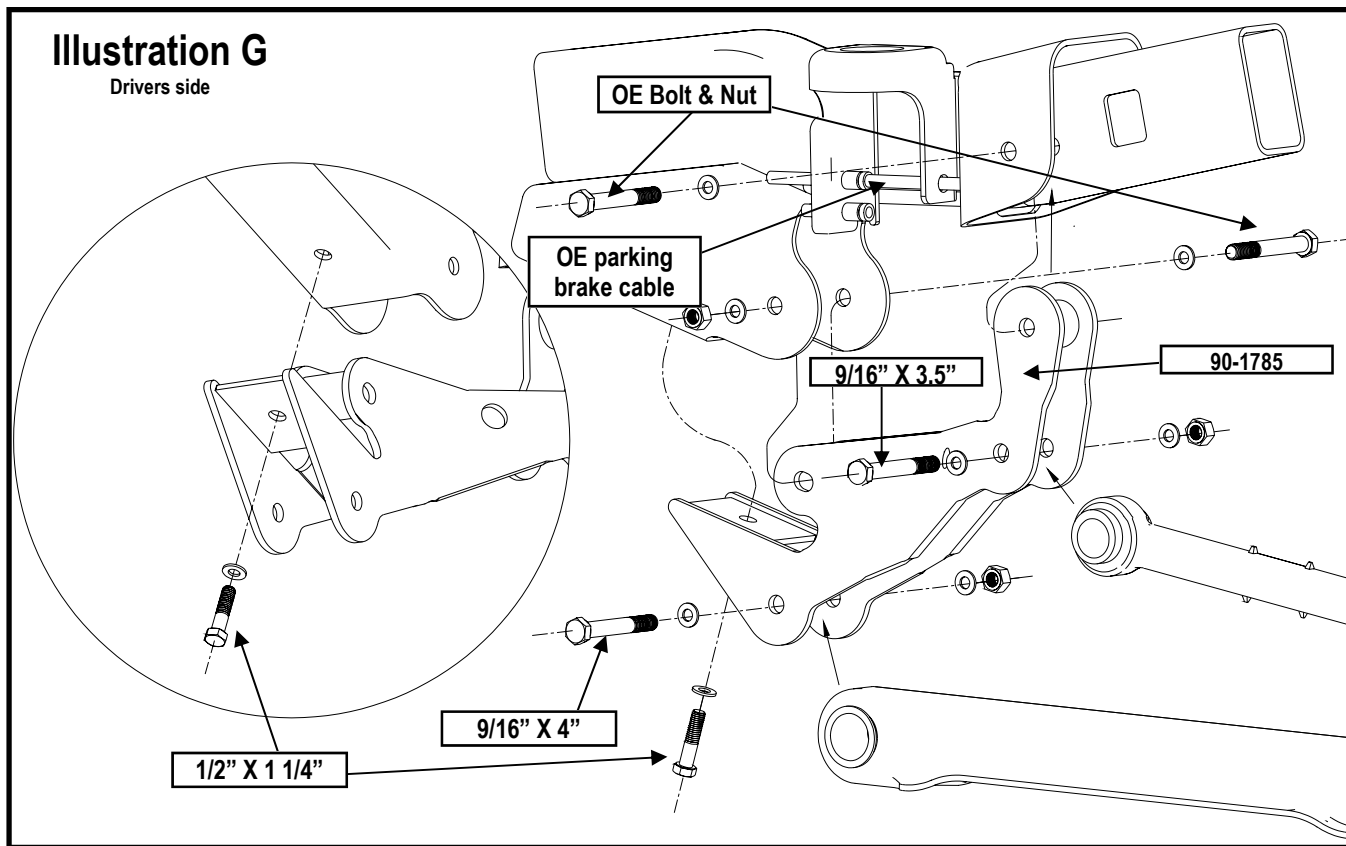

torque specs.

33. Recheck for proper installation, then torque all newly installed hardware.
34. After 100 miles, recheck for proper torque on all newly installed hardware.
35. Recheck all hardware for tightness after each off road use. ⚠

Bolt Torque and ID

Decimal System

Metric System

All Torques in Ft. Lbs.

Bolt Size	Grade 5	Grade 8	Bolt Size	Class 9.8	Class 10.9	Class 12.9
5/16	15	20	M6	5	9	12
3/8	30	45	M8	18	23	27
7/16	45	60	M10	32	45	50
1/2	65	90	M12	55	75	90
9/16	95	130	M14	85	120	145
5/8	135	175	M16	130	165	210
3/4	185	280	M18	170	240	290

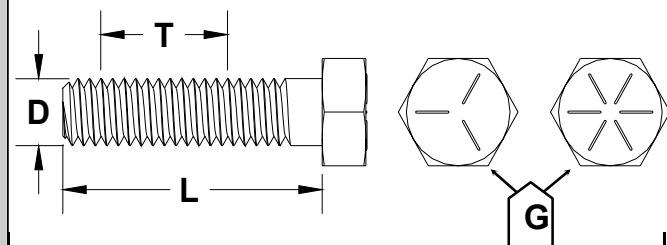

1/2-13x1.75 HHCS



Grade 5 Grade 8
(No. of Marks + 2)

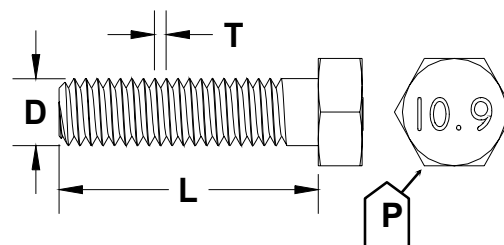

M12-1.25x50 HHCS



G = Grade (Bolt Strength)
D = Nominal Diameter (Inches)
T = Thread Count (Threads per Inch)
L = Length (Inches)
X = Description (Hex Head Cap Screw)

P = Property Class (Bolt Strength)
D = Nominal Diameter (Millimeters)
T = Thread Pitch (Thread Width, mm)
L = Length (Millimeters)
X = Description (Hex Head Cap Screw)

Notice to Owner operator, Dealer and Installer:

Vehicles that have been enhanced for off-road performance often have unique handling characteristics due to the higher center of gravity and larger tires. This vehicle may handle, react and stop differently than many passenger cars or unmodified vehicles, both on and off-road. You must drive your vehicle safely! Extreme care should always be taken to prevent vehicle rollover or loss of control, which can result in serious injury or even death. Always avoid sudden sharp turns or abrupt maneuvers and allow more time and distance for braking! Pro Comp reminds you to fasten your seat belts at all times and reduce speed! We will gladly answer any questions concerning the design, function, maintenance and correct use of our products.

Please make sure your Dealer/Installer explains and delivers all warning notices, warranty forms and instruction sheets included with Pro Comp product.

Application listings in this catalog have been carefully fit checked for each model and year denoted. However, Pro Comp reserves the right to update as necessary, without notice, and will not be held responsible for misprints, changes or variations made by vehicle manufacturers. Please call when in question regarding new model year, vehicles not listed by specific body or chassis styles or vehicles not originally distributed in the USA.

Please note that certain mechanical aspects of any suspension lift product may accelerate ordinary wear of original equipment components. Further, installation of certain Pro Comp products may void the vehicle’s factory warranty as it pertains to certain covered parts; it is the consumer’s responsibility to check with their local dealer for warranty coverage before installation of the lift.

Warranty and Return policy:

Pro Comp warrants its full line of products to be free from defects in workmanship and materials. Pro Comp’s obligation under this warranty is limited to repair or replacement, at Pro Comp’s option, of the defective product. Any and all costs of removal, installation, freight or incidental or consequential damages are expressly excluded from this warranty. Pro Comp is not responsible for damages and / or warranty of other vehicle parts related or non-related to the installation of Pro Comp product. A consumer who makes the decision to modify his vehicle with aftermarket components of any kind will assume all risk and responsibility for potential damages incurred as a result of their chosen modifications. Warranty coverage does not include consumer opinions regarding ride comfort, fitment and design. Warranty claims can be made directly with Pro Comp or at any factory authorized Pro Comp dealer.

IMPORTANT! To validate the warranty on this purchase please be sure to mail in the warranty card.

Claims not covered under warranty-

- Parts subject to normal wear, this includes bushings, bump stops, ball joints, tie rod ends and heim joints
 - Discontinued products at Pro Comp’s discretion
- Bent or dented product
- Finish after 90 days
- Leaf or coil springs used without proper bump stops
- Light bulbs
- Products with evident damage caused by abrasion or contact with other items
- Damage caused as a result of not following recommendations or requirements called out in the installation manuals
- Products used in applications other than listed in Pro Comp’s catalog
- Components or accessories used in conjunction with other manufacturer’s systems
- Tire & Wheel Warranty as per Pro Competition Tire Company policy
- Warranty claims without “Proof of Purchase”
- Pro Comp Pro Runner coil over shocks are considered a serviceable shock with a one-year warranty against leakage only. Rebuild service and replacement parts will be available and sold separately by Pro Comp. Contact Pro Comp for specific service charges.
- Pro Comp accepts no responsibility for any altered product, improper installation, lack of or improper maintenance, or improper use of our products.

E-Mail: tech@explorerprocomp.com
Website: www.explorerprocomp.com
Fax: (619) 216-1474
Ph: (619) 216-1444

PLACE
<u>WARRANTY REGISTRATION</u>
<u>NUMBER</u>
HERE: _____