

2360 Boswell Road
Chula Vista, CA 91914
Phone 619.216.1444
Fax 619.216.1474
E-Mail tech@explorerprocomp.com



PRO COMP SUSPENSION

Suspension Systems that Work!

NOTE: Installation of inner fender relocation bracket kit (PN 90-6640B) is advised when installing 35" tires on a 2008 model.

**6" Lift Kit - 51800/51800MX
2000 - 2008
Chevrolet/GMC 3/4 ton 4X4**

This document contains very important information that includes warranty information and instructions for resolving problems you may encounter. Please keep it in the vehicle as a permanent record.

INSTALLATION INSTRUCTIONS

IMPORTANT: GM has changed the under side of the upper control arms in some 2006 models. If this suspension kit is installed on a vehicle equipped with these open upper A-arms, the bump stops will not make contact with the underside of the upper A-arms. If your vehicle is equipped with open upper A-arms you will need to install the bump stop plates from pack 90-6481. This hardware pack must be purchased separately.

Part List:

Box 1 of 5 PN 51800-1

PART#	DESCRIPTION	QUANTITY	ILLUSTRATION#
90-2225	DIFFERENTIAL TORQUE STRUT ASSY.	1	4
90-3086	HD FRONT LOWER CROSS MEMBER	1	8,11
95-400	4" LIFT BLOCK	2	27
90-3113	BUMP STOP SPACER	2	29
90-3114	BUMP STOP SPACER	2	29
MO2168-BK-01	BUMP STOP	2	29
13-90347	U-BOLTS, 5/8" - 18 X 2 5/8" X 14" LONG	4	27
20-65471	U-BOLT HARDWARE PACK	1	-
90-6191	HARDWARE PACK, CENTERLINK	1	-
70-0503251800	1/2" X 3 1/4" GRADE 8 HEX BOLT	2	8
73-05000034	1/2" SAE GRADE 8 FLAT WASHER	12	8,9
70-0503751800	1/2" X 3 3/4" GRADE 8 HEX BOLT	3	9,11
73-05000038	1/2" AN FLAT WASHER	4	11
72-05000100816	1/2" TOP LOCK NUT	6	9,11
70-0504001800	1/2" X 4" GRADE 8 HEX BOLT	1	9
90-6192	HARDWARE PACK, CENTERLINK	1	-
90-2075	SPACER, 3/4" OD X 1/8" WALL X 5/16", UPPER	2	8
90-2180	SPACER, 1 1/2" OD X 1/2" ID X 1/2"	2	11
90-4036	REDUCER CONE	4	11
90-2002	1 1/32" CONICAL SPACER	1	9
90-2136	SPACER, 3/4" OD X 1/8" WALL X 1.225"	1	9
90-4053	STEERING LINK SUPPORT	2	8
90-2014	SPACER, 3/4" OD X 1/8" WALL X 1/4", LOWER: NOT USED	2	8
96-1505	WELD IN PLATE	1	3
90-6303	HARDWARE PACK: FRONT BRAKE LINE	1	
90-1868	FRONT BRAKE LINE DROP	2	
90-6299	HARDWARE PACK	1	
90-6189	DIFF VENT	1	
90-6481	HARDWARE PACK, A-ARM WELD IN PLATES	1	
96-3586	A-ARM BUMP STOP WELD IN PLATE- DRVR	1	
96-3587	A-ARM BUMP STOP WELD IN PLATE-PASS	1	
90-3808	STEERING STOP	2	
90-6555	HARDWARE PACK, STEERING STOP	1	
70-0312001800	5/16" X 2" GR. 8 HEX BOLT	2	
73-03100034	5/16" SAE FLAT WASHER	4	
72-03100100816	5/16" GR.8 STOVER NUT	2	

Box 2 of 5 PN 51800-2

90-1446	DRIVER DIFFERENTIAL DROP	1	4
90-1635	UNIVERSAL,TORSION DROP BRACKET	2	21
90-1636	TORSION DROP ADAPTER, CHEV/GMC 02	2	21
90-1638	TORSION DROP ADAPTER, CHEV/GMC 99-01	2	21
90-2222	HD CENTERLINK DROP	1	9,11
90-1545	PASSENGER DIFFERENTIAL DROP	1	5

Box 2 of 5 PN 51800-2

PART#	DESCRIPTION	QUANTITY	ILLUSTRATION#
90-1435	COMPRESSION STRUT MOUNTS	2	24,25,26
90-1548	UPPER A-ARM MOUNT, DRIVER REAR	1	12
90-1553	UPPER A-ARM MOUNT, PASSENGER REAR	1	14
90-1558	UPPER A-ARM MOUNT, PASSENGER FRONT	1	15
90-1584	UPPER A-ARM MOUNT, DRIVER FRONT	1	13
90-6223	HARDWARE PACK, UNIVERSAL TORSION DROP ADAPTERS	1	-
70-0371251800	3/8" X 1 1/4" GRADE 8 HEX BOLT	4	21
72-03700100816	3/8" TOP LOCK NUT	4	21
73-03700034	3/8" SAE GRADE 8 FLAT WASHER	8	21
90-6193	HARDWARE PACK, DIFFERENTIAL DROP	1	-
70-0561501800	9/16" X 1 1/2" GRADE 8 HEX BOLT	2	5
73-05600034	9/16" SAE GRADE 8 FLAT WASHER	8	5
73-05600042	9/16" USS GRADE 8 FLAT WASHER	2	5
72-05600100816	9/16" TOP LOCK NUT	4	4,5
70-0564001800	9/16" X 4" GRADE 8 HEX BOLT	1	4
70-0561251800	9/16" X 1 1/4" GRADE 8 HEX BOLT	1	4
90-6181	HARDWARE PACK, SHOCK ADAPTER	1	-
90-1079	SHOCK ADAPTER	2	18
70-0502751500	1/2" X 2 3/4" GRADE 5 HEX BOLT	2	18
73-05000034	1/2" SAE GRADE 8 FLAT WASHER	4	18
73-05000100516	1/2" TOP LOCK NUT	2	18
72-06200100512	5/8" USS GRADE 5 NYLOCK NUT	2	18
73-06200032	5/8" USS FLAT WASHER	2	18
54314	SHOCK SLEEVE	2	9
90-6194	HARDWARE PACK, TORSION / COMPRESSION	1	-
70-0504001800	1/2" X 4" GRADE 8 HEX BOLT	4	23,26
73-05000034	1/2" SAE GRADE 8 FLAT WASHER	8	23,26
73-05000100816	1/2" TOP LOCK NUT	4	23,26
70-0501251800	1/2" X 1 1/4" GRADE 8 HEX BOLT	2	26
70-0431251800	7/16" X 1 1/4" GRADE 8 HEX BOLT	8	21,22
73-04300034	7/16" SAE GRADE 8 FLAT WASHER	16	21,22
72-04300100816	7/16" TOP LOCK NUT	8	21,22
70-0371251800	3/8" X 1 1/4" GRADE 8 HEX BOLT	4	29
73-03700034	3/8" SAE GRADE 8 FLAT WASHER	10	29
72-03700100816	3/8" TOP LOCK NUT	6	29
90-6177	PARTS PACK, TORSION DROP	1	-
15-11149	TORSION DROP BUSHINGS	4	23
90-2011	TORSION DROP SLEEVES 1"X.05"X1.5	2	23
90-6195	HARDWARE PACK, UPPER A-ARM	1	-
70-0561501800	9/16" X 1 1/2" GRADE 8 HEX BOLT	8	12,13,14,15
73-05600034	9/16" SAE GRADE 8 FLAT WASHER	16	12,13,14,15
72-05600100816	9/16" TOP LOCK NUT	8	12,13,14,15
70-0501251800	1/2" X 1 1/2" GRADE 8 HEX BOLT	4	12,13,14,15
73-05000034	1/2" SAE GRADE 8 FLAT WASHER	14	12,13,14,15
72-05000100816	1/2" TOP LOCK NUT	7	12,13,14,15
70-0503251800	1/2" X 3 1/2" GRADE 8 HEX BOLT	2	12,14
70-0503751800	1/2" X 3 3/4" GRADE 8 HEX BOLT	1	15
90-6298	HARDWARE PACK: BRAKELINE / PARKING BRAKE DROP	1	-
90-1817	BRAKELINE DROP BRACKET-REAR	1	21
90-1083	PARKING BRAKE CABLE EXTENSION BRACKET (STRAIGHT)	1	21
90-6299	HARDWARE PACK: BRAKELINE DROP KIT	1	-
70-0311001500	5/16" X 1" GR 5 HEXBOLT	2	21
72-03100100512	5/16" NYLOCK NUT	2	21
73-03100030	5/16" SAE FLAT WASHER	4	21

Box 3 of 5 PN 51800-3

90-6280	HARDWARE PACK, SHOCK RELOCATION	1	-
90-1580	SHOCK RELOCATION BRACKET, PASS	1	16,17,19
90-1581	SHOCK RELOCATION BRACKET, DRIVER	1	16,17,19
70-05027551500	1/2" X 2 3/4" USS GRADE 5 HEX BOLT	2	19

PART#	DESCRIPTION	QUANTITY	ILLUSTRATION#
72-05000100512	1/2" NYLOCK NUT	2	19
73-05000030	1/2" SAE FLAT WASHER	4	19
90-2126	COMPRESSION STRUTS	2	23,24,25,26
90-1562	REAR CROSSMEMBER	1	6
90-6100	SWAY BAR END LINK KIT	1	-
90-2122	SWAY BAR EXTENSION	2	18
90-6065	HARDWARE PACK	1	-
90-1010	SWAY BAR FRONT MOUNT BRACKET	2	18
117300007	RETAINER WASHER	4	18
45359	BLACK HOURGLASS BUSHING	2	18
61150	SLEEVE, 5/8" x 1.48" LENGTH	2	18
90-2039	SLEEVE, 5/8" x 1/4" LENGTH	2	18
8337-1	3/8" SAE HEX NUT	2	18
90-6024	HARDWARE PACK	1	-
70-0371501500	3/8" X 1 1/2" BOLT	2	18
70-0372501500	3/8" X 2 1/2" BOLT	2	18
72-03700100512	3/8" NYLOCK NUT	4	18
73-03700030	3/8" SAE FLAT WASHER	4	18
73-03700042	3/8" USS HARDENED FLAT WASHER	2	18
90-6196	HARDWARE PACK, CROSS MEMBER	1	-
70-0624501800	5/8" X 4 1/2" GRADE 8 HEX BOLT	2	16
73-06200034	5/8" SAE GRADE 8 FLAT WASHER	8	16
72-06200100816	5/8" TOP LOCK NUT	4	16
70-0625501800	5/8" X 5 1/2" GRADE 8 HEX BOLT	2	16
73-03700030	3/8" SAE FLAT WASHER	4	10
72-03700100816	3/8" TOP LOCK NUT	4	10
70-0310751800	5/16" X 3/4" GRADE 8 HEX BOLT	2	19
72-0310010816	5/16" TOP LOCK NUT	2	19
73-03100030	5/16" SAE FLAT WASHER	4	19
90-6197	PARTS PACK, URETHANE	1	-
90-1539	BRAKE LINE EXTENSION BRACKET	2	19,20
15-11018	LOW PROFILE BUMP STOP	2	10
15-11031	CONE BUMP STOP	2	10
90-1582	1/2" NUT PLATE	2	26
90-6263	PARTS PACK, COMPRESSION STRUT	1	-
90-2109	COMPRESSION STRUT SLEEVES	4	23,26
15-11148	COMPRESSION STRUT BUSHINGS	8	23,26
90-6170	HARDWARE PACK CAM BOLTS	2	17
42-778T	CAM BOLT	4	17
219200	STEERING STABILIZER	1	9
Box 4 of 5 PN 51800-4			
920508	ES 9000 SERIES SHOCKS, FRONT	2	18
929505	ES 9000 SERIES SHOCKS, REAR	2	
OR			
Box 4 of 5 PN 51800mx-4			
MX6002	MX6 SERIES SHOCKS, FRONT	2	18
MX6003	MX6 SERIES SHOCKS, REAR	2	
Box 5 of 5 PN 51800-5			
13125-1	ADD-A-LEAF	2	27
90-8337-1	3/8" CENTER BOLT	2	27

Equipment Available from your Pro Comp Distributor!

MX6141R: Rear MX-6 Reservoir Shocks

90-6640B: Front Inner Fender Relocation Bracket Kit

Also, Check out our outstanding selection of Pro Comp tires to compliment your new installation!

Introduction:

51800
Revised
2.19.2008

- ◆ This installation requires a professional mechanic!
- ◆ We recommend that you have access to a GM service manual for your vehicle to assist in the disassembly and reassembly of your vehicle. It contains a wealth of detailed information.
- ◆ Prior to installation, carefully inspect the vehicle's steering and driveline systems paying close attention to the tie rod ends, ball joints, wheel bearing preload, pitman and idler arm. Additionally, check steering-to-frame and suspension-to-frame attaching points for stress cracks. The overall vehicle must be in excellent working condition. Repair or replace all worn or damaged parts!
- ◆ Read the instructions carefully and study the illustrations before attempting installation! The more familiar you are with the procedures, the easier and quicker your installation will be.
- ◆ Check the parts and hardware against the parts list to assure that your kit is complete. Separating parts according to the areas where they will be used and placing the hardware with the brackets before you begin will save installation time.
- ◆ Secure and properly block vehicle prior to beginning installation.
- ◆ **ALWAYS** wear safety glasses when using power tools or working under the vehicle!
- ◆ Use caution when cutting is required under the vehicle. The factory undercoating is flammable. Take appropriate precautions. Have a fire extinguisher close at hand.
- ◆ Foot pound torque readings are listed on the Torque Specifications chart at the end of the instructions. These are to be used unless specifically directed otherwise.

Please Note:

- ◆ Front end realignment will be necessary.
- ◆ Speedometer and ABS recalibration are necessary if larger tires (10% more than stock diameter) are installed.
- ◆ This system utilizes the stock torsion bars which normally afford the best ride quality. If, after the kit is installed, ride or handling seems too "soft", heavier Gross Vehicle Weight Rating (GVWR) bars can be installed. GM offers various bars up to 10,000 lbs. GVWR.
- ◆ Due to differences in manufacturing, dimensions and inflated measurements, tire and wheel combinations should be test fit prior to installation. Tire and wheel choice is crucial in assuring proper fit, performance, and the safety of your Pro Comp equipped vehicle. For this application, we recommend a wheel not to exceed 8" in width with a minimum backspacing of 4" must be used. Additionally, a quality tire of radial design, not exceeding 35" tall X 12.5" wide is also recommended. Please note that the use of a 35" X 12.5" tire may require fender modification. Violation of these recommendations will not be endorsed as acceptable by Pro Comp Suspension and will void any and all warranties either written or implied.

NOTE: Installation of inner fender relocation bracket kit (PN 90-6640B) is advised when installing 35" tires on a 2008 model.

- ◆ Purchase of a new PRO COMP drive shaft may be necessary to eliminate driveline vibration.

- **WARNING: Be extremely careful when loading or unloading the torsion bars! There is a tremendous amount of stored energy in the bars. Keep your hands and body clear of the adjuster arm assembly and puller tool in case anything slips or breaks! Remember your safety glasses!**
- While we have listed the hardware that is to be kept and that to be discarded, it would be wise to keep all hardware until the installation is complete.

Note: A special puller tool is required for safe removal and installation of the torsion adjuster arms. This special puller can be purchased from you local GM dealer (Tool #J36202) or from Kent Moore Tool Group in Roseville, MI. (800) 345-2233 or (313) 774-9500 (Part #J22517-C). You may be able to rent one of these tools at your local parts store. Refer to the GM service manual for more information.

Front Disassembly:

1. Ensure that your work space is of adequate size and the work surface is level. Place the vehicle in neutral. Place your floor jack under the front cross member and raise vehicle. Place jack stands under the frame rails behind the front wheel wells and lower the frame onto the stands. Remove the jack and place the vehicle back in gear, set the emergency brake, and place blocks both in front of and behind the rear wheels.
2. If there are factory skid plates installed, remove them.
3. Measure the torsion bar adjusting screw depth and record for later use when replacing the torsion adjuster arm on reassembly. Apply a small amount of lubrication grease to the special puller threads and the puller shaft-to-adjuster arm contact point. Load the puller and torsion adjuster arm until the adjuster bolt can be easily backed off and the nut can be removed from the cross member. Back the puller off to unload the torsion bar. With the bar unloaded, slide it forward into the lower control arm until the adjuster arm falls free. If the bar seems stuck, use a hammer and punch through the hole in the rear of the cross member to dislodge it. Repeat this procedure for the other side of the vehicle.
4. Mark the torsion bars as to their orientation (left side, right side, and front). They ***must*** be reinstalled exactly as removed! Remove the torsion bar cross member by removing the through bolts on each side of the vehicle. With the cross member out of the way, the torsion bars can be pulled from the lower control arms and removed.

Note: Steps 5 through 22 are performed one side at a time:

5. Disconnect the ABS sensor wire and position it out of the way to prevent damage to the wiring or connector ends. Remove brake caliper assembly and securely fasten it away from the work area.
6. Remove the 6 bolts that attach the CV axle to the differential. Save these for reuse.
7. Remove the outer end of the tie rod from the spindle assembly. Special tools are available to safely remove these without damage to the joint or the protective boot. Your GM service manual has details on this procedure.

8. Remove the anti-sway bar links that connect the sway bar to the lower A-arm and remove the sway bar. Save the rubber bushings from the links.
9. Remove the shock absorber from the lower mount and remove the mount adapter from the lower A-arm. Save these bolts.
10. Remove the upper and lower A-arm pivot nuts. Save this hardware for reuse on reassembly.
11. Support the A-arm assembly and carefully remove the pivot bolts. Lower the assembly to the floor and set aside. Use caution when removing this assembly, it is heavy and not rigid. Save the pivot bolts for reuse.
12. Remove the upper shock nut and remove the stock shock absorber. Discard these parts.
13. Detach the front drive shaft from the differential yolk and secure it out of the way. Disconnect the electronic wiring and vent line from the differential and secure them out of the way.
14. Remove the factory bump stops and droop stops. Discard.
15. Remove the drag link from the pitman arm and idler arm. In some cases it may be easier to remove the idler arm from the frame with the drag link. Set this assembly aside. Save the nuts for reuse.
16. Remove the differential cross member and discard.
17. Remove the front differential lower mounting bolt. Save this nut and bolt for reuse.
18. Remove the passenger side differential mounting bolts. Save this hardware for reuse.
19. While supporting the differential, remove the upper differential mount bolt and lower the differential to the ground. Retain this nut and bolt for reuse on reassembly.

20. Using **ILLUSTRATION 1** as a reference, remove the bump and droop stop sheet metal from the area around the upper rear A-arm mounts. A reciprocating saw will work for this chore. If you decide to use a cutting torch, be extremely careful! *The factory corrosion inhibitor is wax-based and very flammable!* Before you use a torch, ensure there is another person watching and a fire extinguisher handy. The bump stop sheet metal must be completely removed.

21. **ILLUSTRATION 2** shows additional cuts that have to be made for clearance of the rear upper A-arm drops. On completion of the cuts, test fit the drops to ensure adequate clearance and trim additional metal as needed. Remove only enough material for clearance.

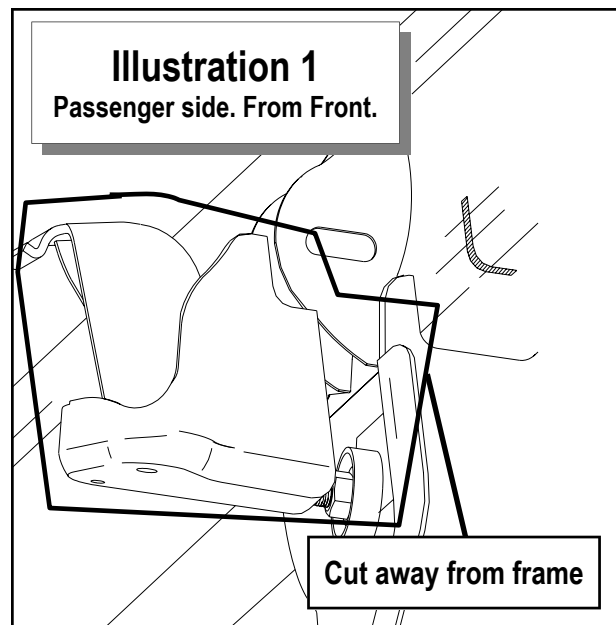

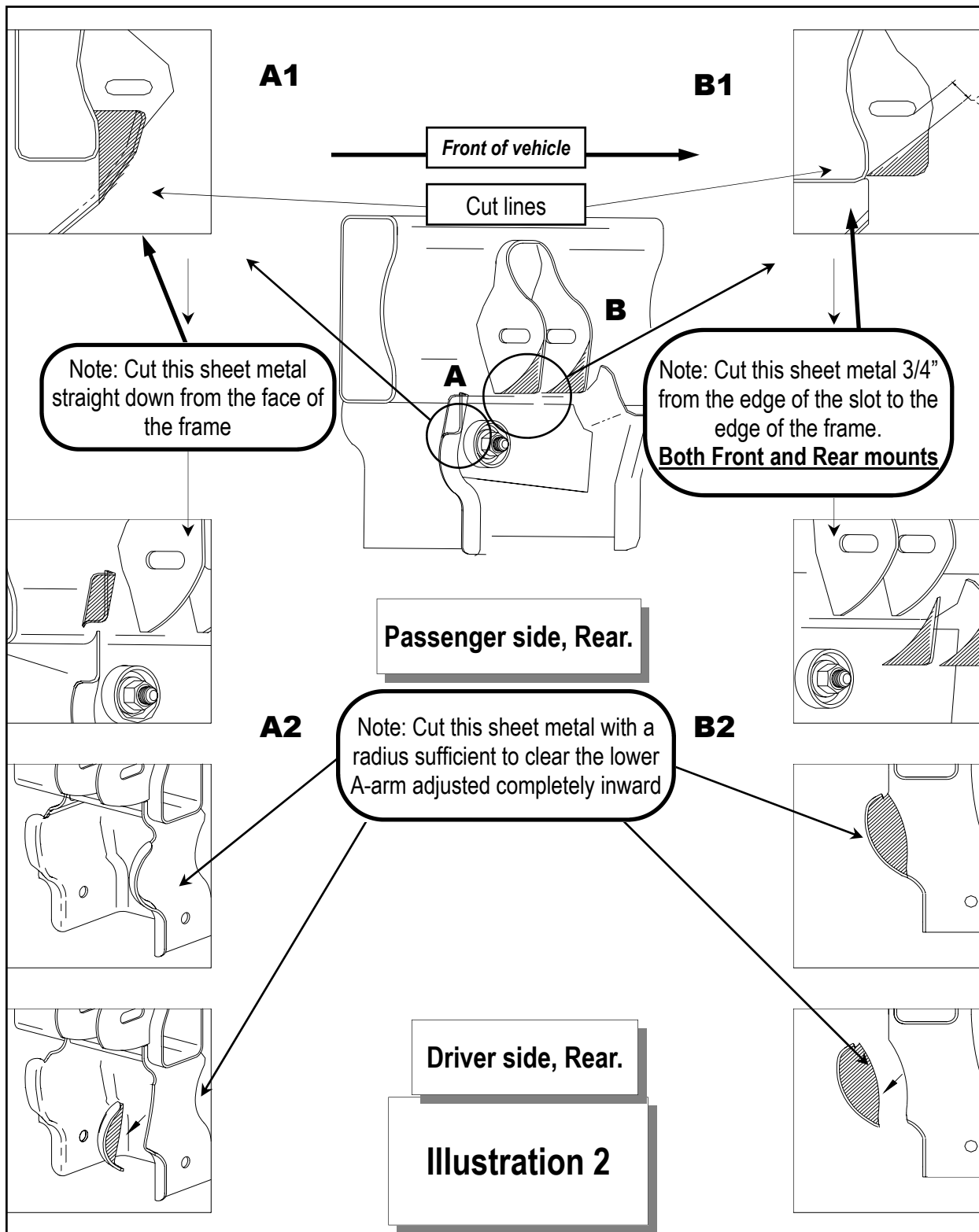

22. Using an angle grinder or equivalent, remove any remaining weld from these areas to achieve a smooth surface and to smooth the cut edges from *step 21*.
23. On the driver side lower A-arm pocket, carefully cut the rear section out using the weld in plate (PN 96-1505) and **ILLUSTRATION 3** as a guide.
24. On the upper A-arm mount pockets, remove the existing alignment cam pins and grind them flush to the pocket surface.
25. There are at least two mounting configurations for the torsion bar cross member. Some models use an aluminum “dog bone” mount from the upper part of the frame. The only modification required of this type of mount is the removal of the “dog bone”. Some models have the cross member mounts riveted to the bottom of the frame rail and must be completely removed. Remove the torsion bar cross member mounts by cutting or grinding the rivet heads off and punching out the remaining rivet body.

Illustration
Drivers Side
OEM

This drawing is a supplement to Illustration 3.

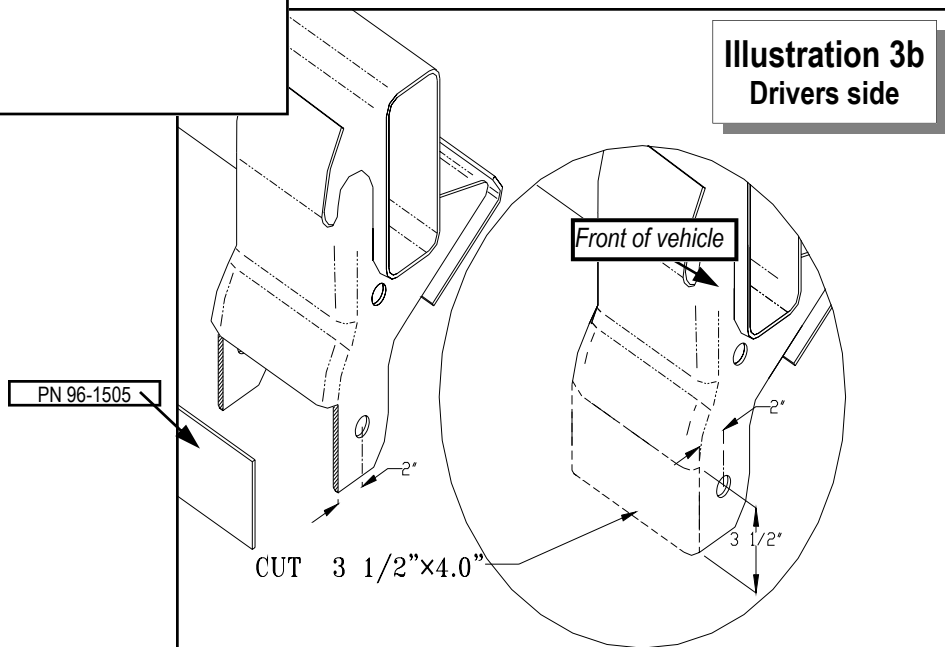
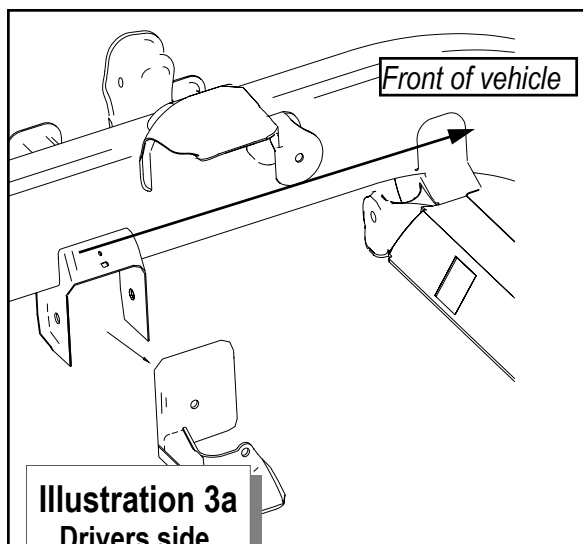

Installation

1. Tack the weld in plate (PN 96-1505) to the back of the pocket. **DO NOT** finish welding until the front differential has been reinstalled to ensure there is adequate clearance between the differential and the frame.
2. *One at a time*, position the A-arm drops into their respective positions. (PN 90-1548 = Driver Rear, PN 90-1584 = Driver Front, PN 90-1553 = Passenger Rear, 90-1558 = Passenger front) Each drop has additional mounting holes that must be drilled through the frame. All have one located on the bottom of the frame and all but the driver front have another located on the face that must be drilled through both sides of the frame rail. The driver side front drop uses the OEM power steering bolt. Clamp each drop firmly to the frame and using the drops as a guide, drill pilot holes. Remove the drop and finish drilling with a 1/2" drill bit. Repeat this for the three remaining drops. **DO NOT BOLT ON AT THIS TIME.** See **ILLUSTRATIONS 12, 13, 14, & 15.**

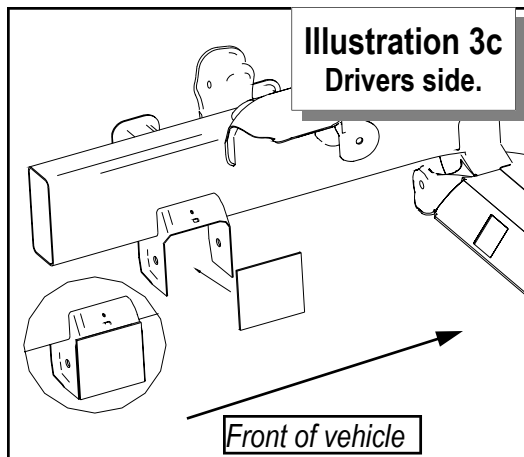

3. Loosely install the differential drop (PN 90-1446) into the OEM location with the OEM nut and bolt. **ILLUSTRATION 4.**

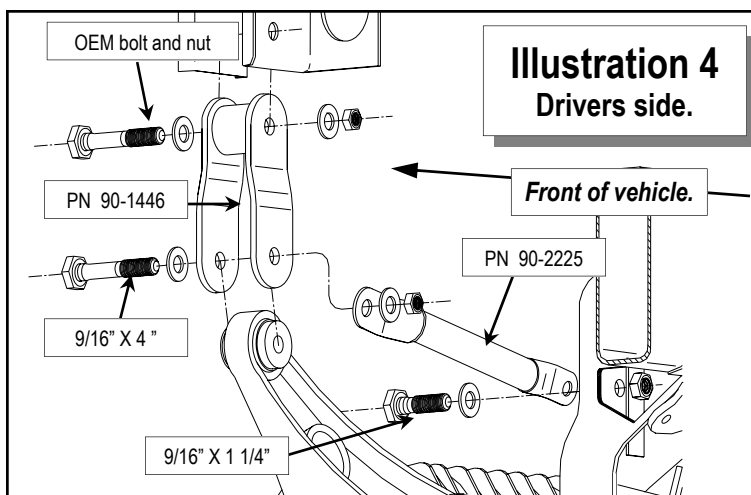

4. Using the OEM nuts and washers, install the passenger side differential drop (PN 90-1545) to the OEM mount as shown in **ILLUSTRATION 5**. The bracket has a tear drop shaped hole in it. **IMPORTANT: Make sure the smaller, pointed end of the tear drop hole is toward the front of the vehicle. Note: this bracket is slightly tapered. The short end of the taper is oriented to the rear of the vehicle.**

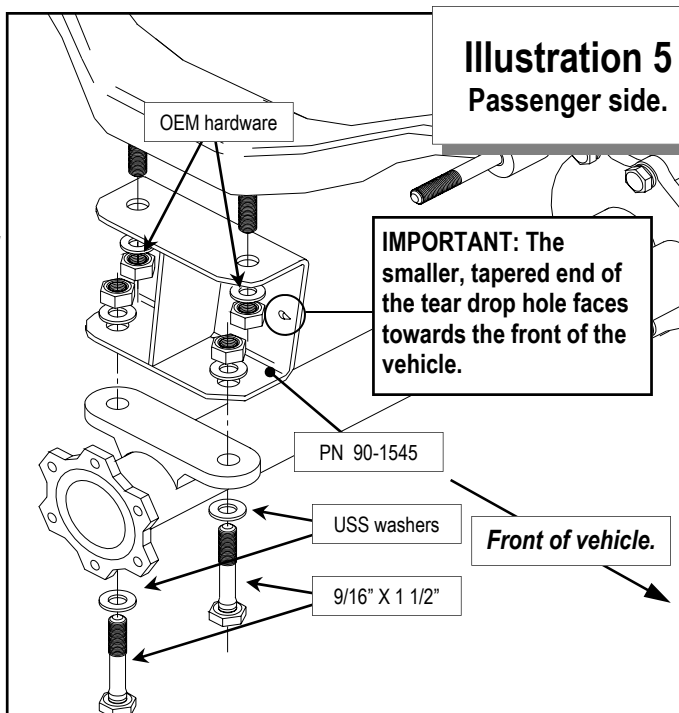

5. Hang the differential from the drivers side drop (PN 90-1446) using the supplied 9/16" X 4 1/4" bolt. Insert the bolt from the center of the truck to the outside also install the supplied torque strut (PN 90-2225) as shown in **ILLUSTRATION 4**. Install the supplied washer and lock nut and

tighten the assembly enough so that the strut can be moved without much effort to complete *step 6*.

6. Attach the differential to the passenger side spacer bracket (PN 90-1545) as shown in **ILLUSTRATION 5** with the supplied 9/16" X 1 3/4" bolts. The large diameter washers go onto the slotted cast iron flange as indicated in the illustration. At this point, leave the fasteners slightly loose until the torque strut is positioned and the main cross member is back in place. *Please note: For 4WD models a small amount of material may have to be removed from the frame around the passenger diff drop for adequate clearance. Maintain a minimum of 1/4" clearance around this flange.*
7. Carefully guide the differential mounting bushing into the mounting flange on the new cross member and install the rear cross member (PN 90-1562) into the truck using the OEM bolts to hold it in place. See **ILLUSTRATIONS 6 & 7**.
8. Install the OEM bolt through the cross member and differential bushing with the threads to the outside of the truck and install the OEM nut. Snug all differential mounting hardware to secure the differential location at this time. See **ILLUSTRATIONS 6 & 7**.
9. Check clearance between the differential and the weld in plate. If needed, remove more material until adequate clearance is achieved.
10. Rotate the differential torque strut to a horizontal position. Mark the location of the mounting hole at the back of the A-

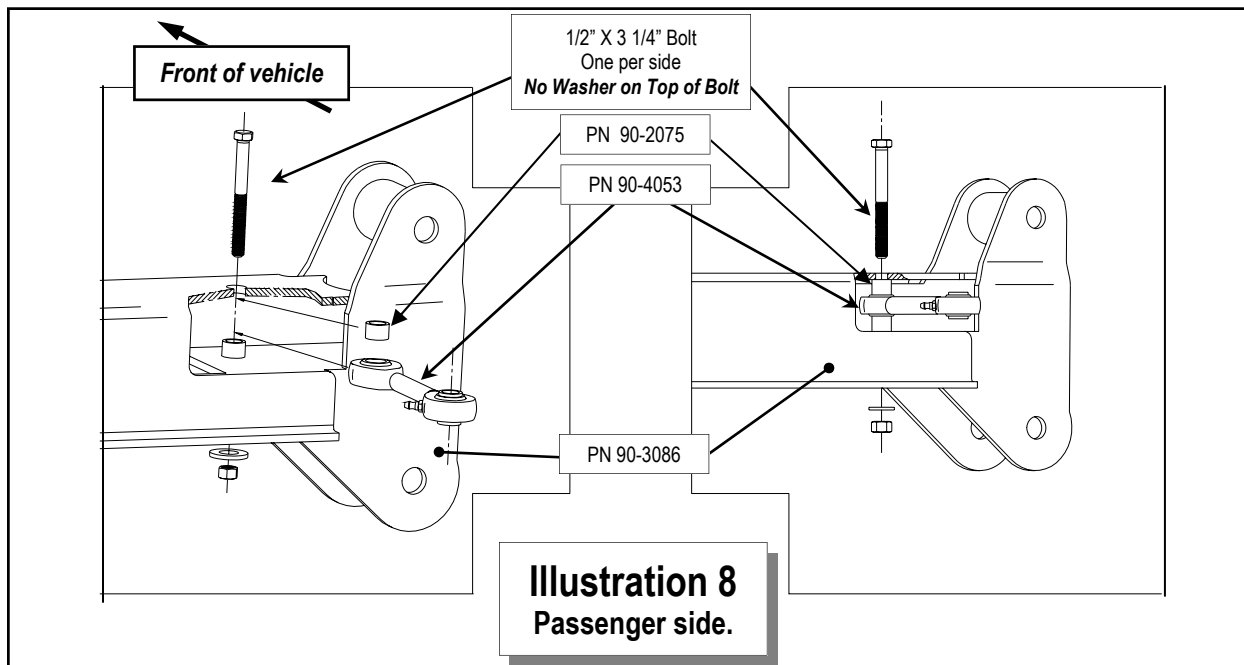
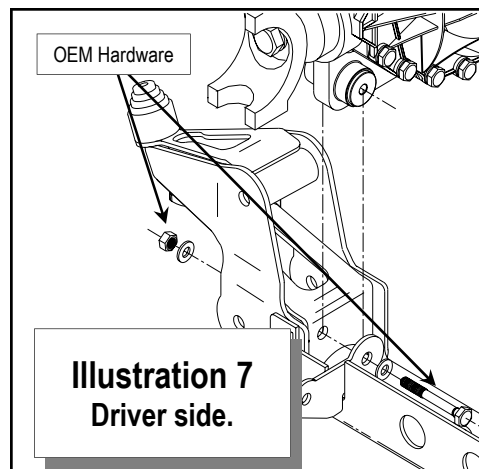
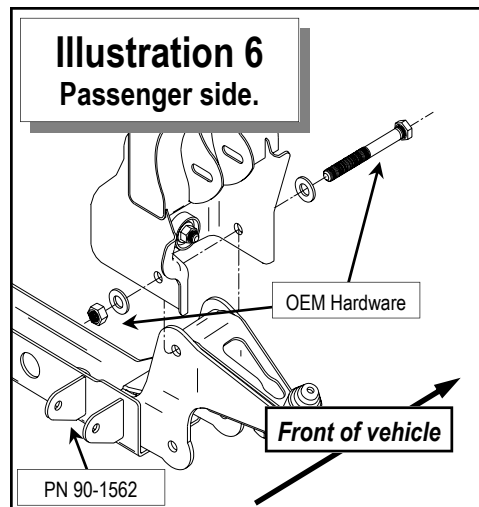

arm pocket.

11. Remove the cross member for access, rotate the strut out of the way and drill the strut mount hole using a 9/16" drill bit.
12. Finish welding the weld in plate (PN 96-1505). Paint the welded areas to prevent rust.
13. Rotate the strut back into place and install the supplied 9/16" X 1 1/4" bolt through the strut and through the frame member. Leave all hardware loose until the completion of the cross member installation.
14. Reinstall the rear cross member. Torque all differential and cross member hardware to specifications.

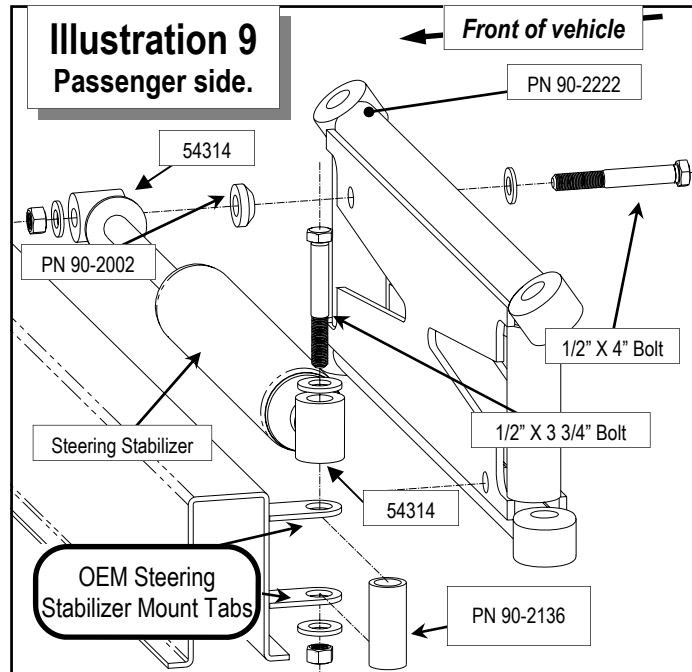

15. With the front cross member on the bench, assemble the link assemblies into the front cross member as shown in **ILLUSTRATION 8**, using the 1/2" X 3 1/4" bolts, with no washers on head of bolt, and spacers (PN 90-2075) provided. Torque the bolts to specifications.
16. Mount the assembled front cross member to the existing front lower A-arm pockets with the OEM bolts and nuts. The link units are oriented to the rear as seen in **ILLUSTRATION 11**. Tighten to specs. *Please note: It may be necessary to clearance the frame above the bolt heads that secure the Steering link supports (PN 90-4053) to the front cross member to avoid contact.*
17. Loosen the steering box bolts, idler arm bolts and install the center link drop (PN 90-2222) to the pitman arm and idler arm using the OEM nuts. Notice that the center link drop taper ends are welded at slightly different angles on each end of the drop. This allows us to accommodate for some variations in vehicle manufacturing. If after initial installation to the pitman and idler arms you notice that the drop interferes with the differential, simply "flip" the center link drop end for end. This will change the drop angle and allow completion of the installation. There is a mount for the steering stabilizer on either end. This mount is oriented to the top right of the center link drop. Use **ILLUSTRATION 9** for reference. When properly installed, the center link will NOT contact the differential and the support links will align properly.
18. Install the supplied bushings and sleeves to the steering stabilizer. Install the steering stabilizer using the sleeves (PN 53134), 1/2" X 3 3/4" bolt and spacer (PN 90-2136) on the driver side mount, the 1/2" X 4" bolt and 1 1/32" conical spacer (PN 90-2002) on the passenger side **ILLUSTRATION 9**.

19. Connect the factory center link, center link drop (PN 90-

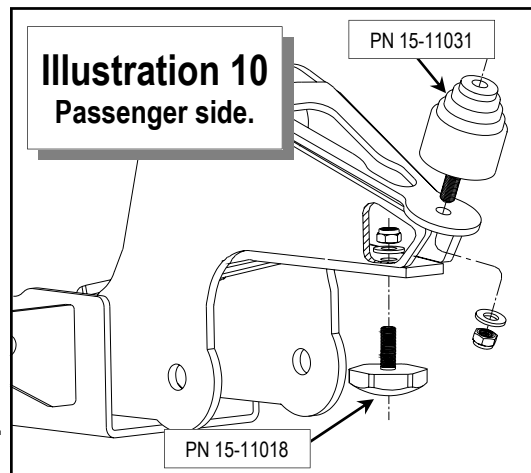

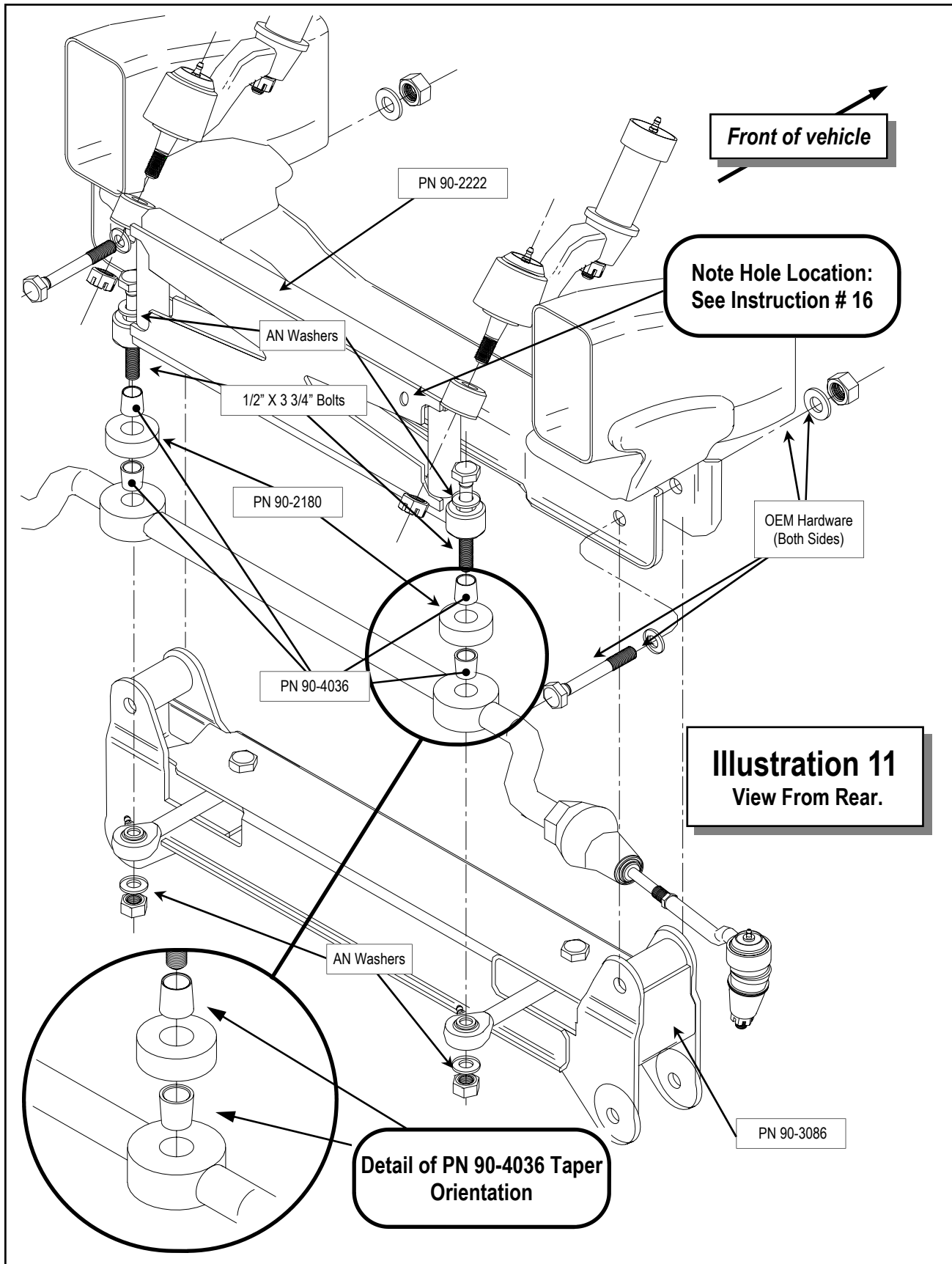

2222), and rod ends from the front cross member to the center link drop using the 1/2" X 3 3/4" bolts, spacers (PN 90-2180), and reducer cones (PN 90-4036) provided. Follow the assembly shown in **ILLUSTRATION 11**. Torque the new bolts according to the torque chart on page 21 and re-torque the steering box and idler arm bolts to Manufacturers specifications.

THESE COMPONENTS MUST BE ASSEMBLED EXACTLY AS SHOWN!!

20. Install the provided replacement bump stops (Lower, PN 15-11018 / Upper, PN 15-11031) to the rear cross member as indicated in **ILLUSTRATION 10**.

Driver Side Views of A-arm Drops

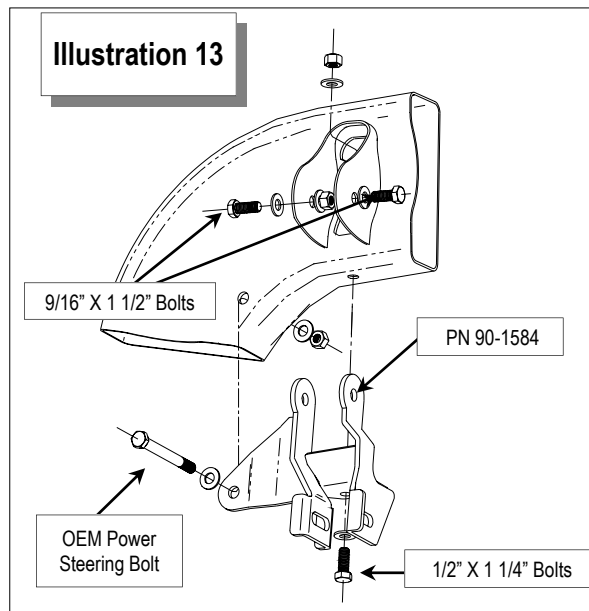
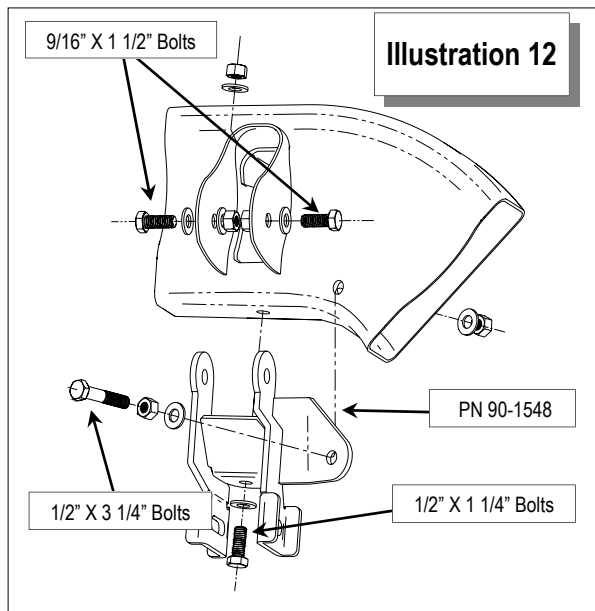

Passenger Side Views of A-arm Drops

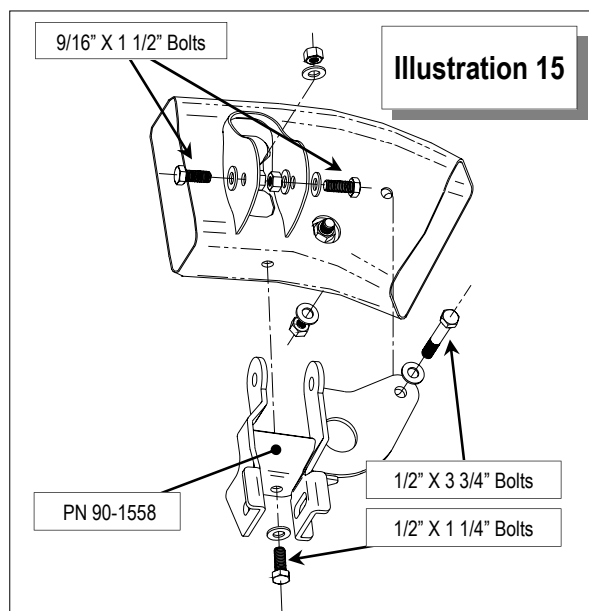
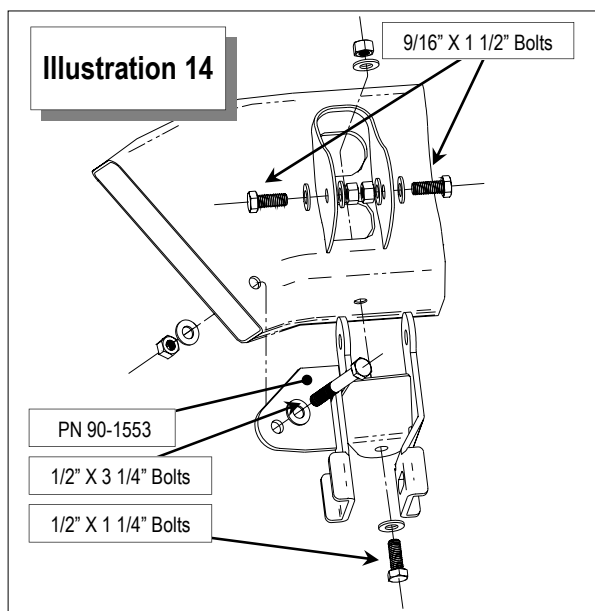

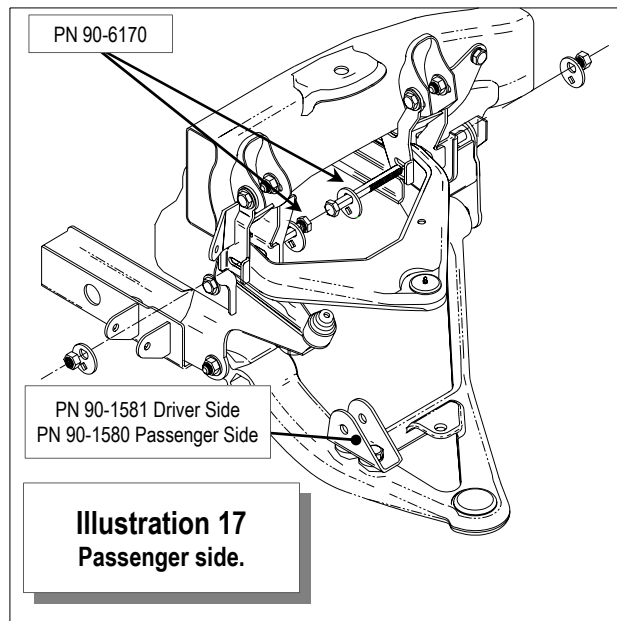
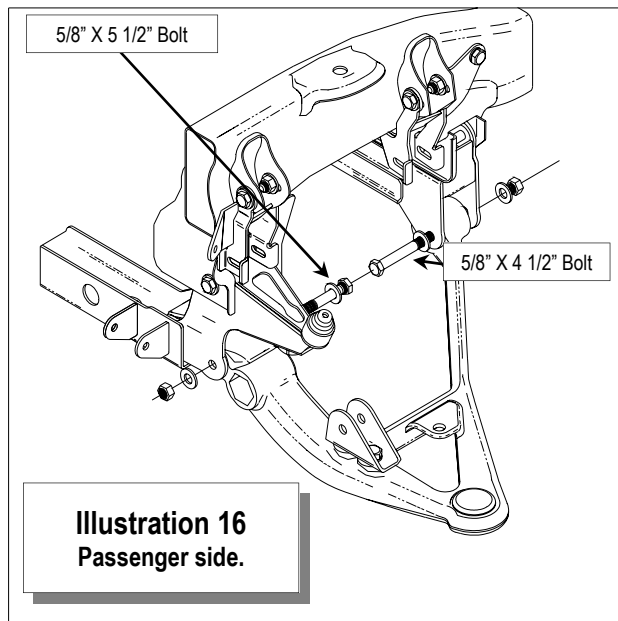

21. If you are *not* installing the multi-shock kit (PN 90-51200), replace A– arm Drops the drops and fasten them to the truck frame using the supplied 1/2” bolts through the frame and the 9/16” X 1 1/4” bolts through the OEM upper A-arm mounts. Tighten all hardware to specifications. **SEE ILLUSTRATIONS 12, 13, 14, & 15** for details. **NOTE: If you are installing hardware pack (PN 90-6481), do so at this time.**

22. If you have purchased the optional multi-shock kit, (PN 90-51200), leave the 9/16” X 1 1/4” upper A-arm drop bolts out and install the kit per the enclosed instructions.

23. Install the A-arm assemblies on each side of the vehicle by reversing the disassembly order. These bolts *must* be oriented with the threads to the outside of the A-arms. Attach the lower A-arms using the supplied 5/8” X 5 1/2” bolts to the rear and the 5/8” X 4 1/2” bolts to the front. The upper A-arms are installed using the alignment cam (PN 90-6170) assemblies. They are installed with the threads *away* from the center of the A-arm. **DO NOT** tighten the cam bolts at this time. To prevent binding or undue stress on the control arm bushings, the vehicle must be fully on the ground before these bolts are torqued to specifications. **SEE ILLUSTRATIONS 16 & 17.**

24. Install the lower shock mounts (PN 90-1580 & 90-1581) at this time. Use the OEM bolts for the bottom mounts. See **ILLUSTRATIONS 19, 17, & 19.**

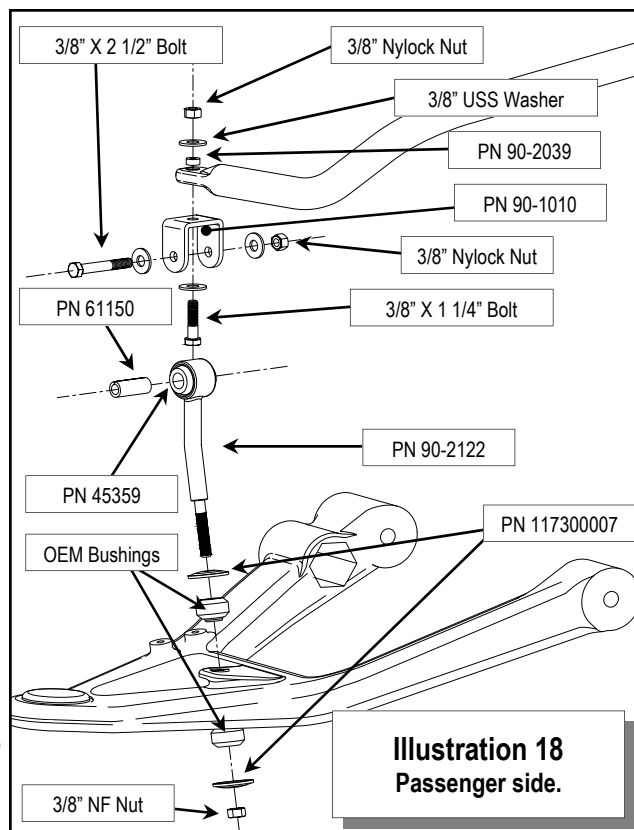

25. Install the factory half shafts to the differential with the OEM bolts. Torque to factory specifications.
26. Install the factory sway bar by flipping it upside down. Use the OEM mounts and bushings on the frame. Using Illustration 18, install the new sway bar links (PN 90-6100). Use the OEM stem bushings. Do not torque hardware until vehicle is on the ground.
27. Using **ILLUSTRATION 19** as a guide, install the Pro Comp shock absorber (PN 320500) to the original position using adapter PN 90-1079 for the upper mount. using the provided 1/2" X 2 3/4" bolts and **nylock nuts** from the adapter through the shock absorber. The lower mounts are offset slightly. The offset places the shock toward the *center* of the lower A-arm.
28. Install the front brake rotors.
29. Install the tie rod ends to the steering knuckle and torque to factory specifications.
30. At this point if you purchased the exhaust modification kit (PN 51810), install it as described in the enclosed instructions and then install the front drive shaft. *If you are not installing this kit, remove the front drive shaft until you can have your local muffler shop reroute the exhaust to clear the shaft.*
31. Install brake line extension brackets (PN 90-1539 or 90-1868 depending amount of slack needed in the hard line) into the OEM brake clamp location as shown in **ILLUSTRATION 20**. The new brackets are oriented down and fastened to the frame with the OEM bolt. The OEM brake looms are mounted to the new brackets using the supplied 5/16" X 3/4" w/ 90-1539 or 5/16" X 1" w/ 90-1868 bolts with the threads oriented away from the frame. Very gently pull slack from the hard line, down the frame rail. Modify the factory support clamps by flattening them, trimming them to length and re-drilling the mount holes. Rotate the clamps to allow the lines to be mounted to

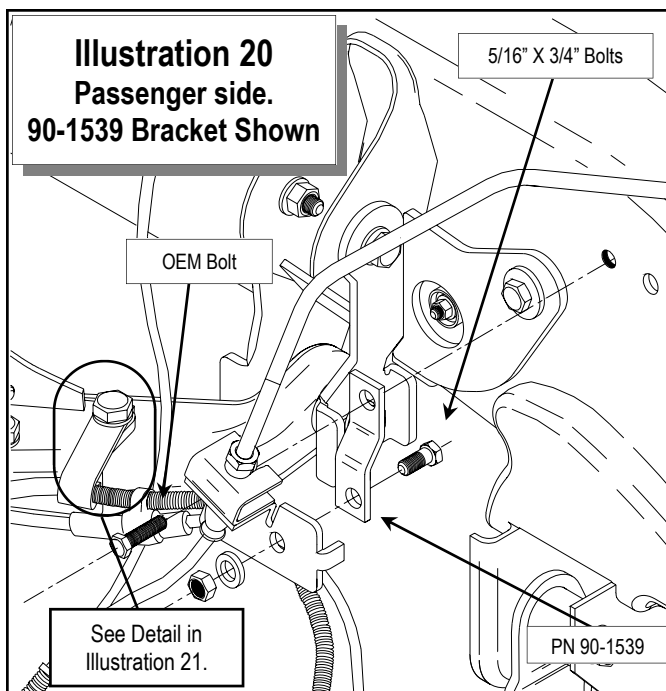
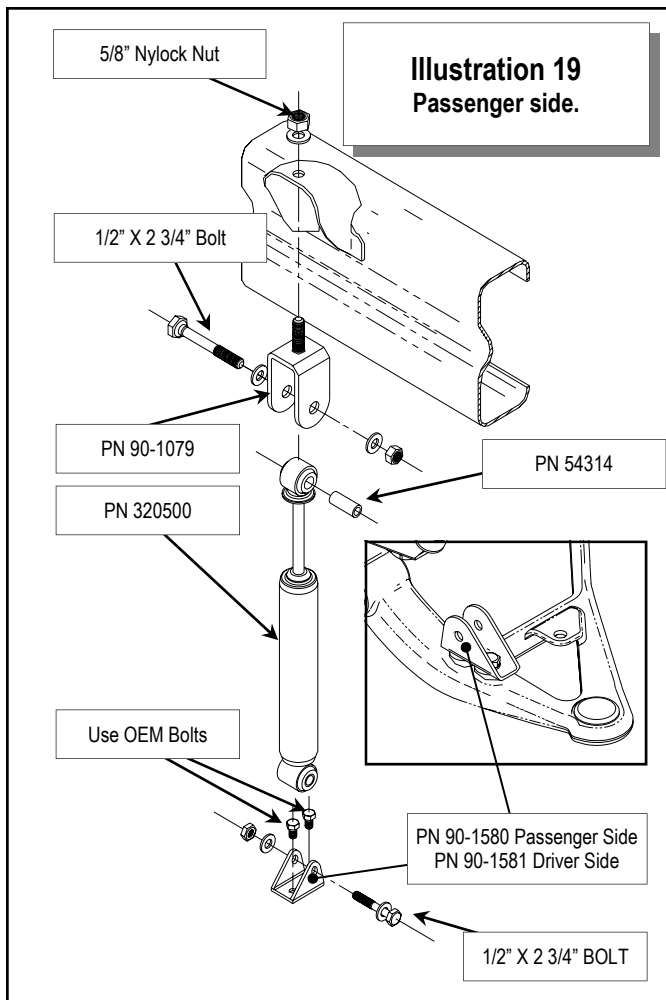

the top, outside of the upper A-arms. See **ILLUSTRATIONS 20 & 21**.

32. Install the front caliper assemblies to each side of the vehicle. Install the ABS sensor wiring and secure them to the brake lines with zip-ties. Again, the harness must be routed to prevent breakage or chaffing. **IMPORTANT:** Move the A-arm assembly up and down to its limits several times to check for binding and to ensure that there are no interference or pinching problems with the brake lines and ABS wiring.

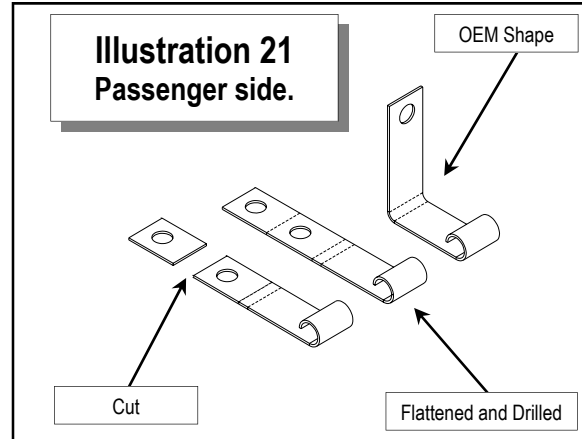

33. Install the universal torsion bar cross member drops by locating part **PN 90-1635** in place as shown in **ILLUSTRATIONS 22 & 23**. Clamp them in place to the bottom and face of the frame rail. The location is determined by centering the drop bracket holes on either side of the OEM mounting rivet holes as shown in the detail view. Drill the four mounting holes per side (top and bottom) using a $7/16$ " drill bit. Using the supplied $7/16$ " X $1\ 1/4$ " bolts, fasten the drops to the frame rails leaving them slightly loose.

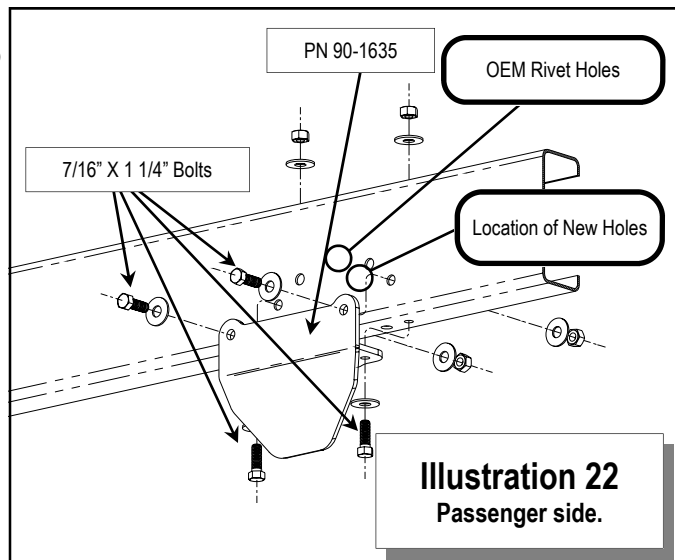

34. From the factory, there are at least two different configurations for the torsion drop brackets. Included in the kit are adapters made specifically for these differences. The primary difference between the two pieces is the width of the cross member. Models with a torsion cross member width of $39\ 5/8$ " (bolt center to bolt center) will use torsion drop adapters **PN 90-1638**. torsion cross members with a width of $40\ 1/2$ " will use **PN 90-1636**. They are mounted to the universal adapters (**PN 90-1635**) using four $3/8$ " X $1\ 1/4$ " bolts from parts pack **90-1623**.

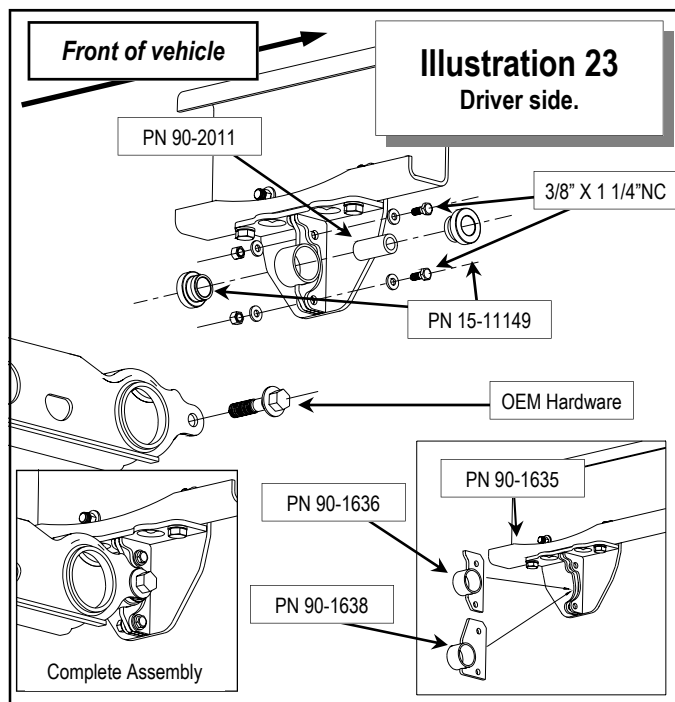

35. Install the torsion bar cross member as shown in **ILLUSTRATION 23**. Torque all fasteners to spec.
36. Install the torsion bars by reversing the order in which they were removed. Again, be very careful to install them with the

same orientation that they were removed (i.e. left front to left front, right front to right front!). Reset the torsion bar preload bolts using the measurements previously taken.

37. Assemble both ends of the compression struts as shown in **ILLUSTRATIONS 24 & 27** using the bushings (PN 15-11148) and sleeves (PN 90-2109).
38. Position the compression struts (PN 90-2126) into the tabs on the front cross member using the supplied 1/2" X 4" bolts, washers, and nuts. See **ILLUSTRATION 24**. The strut ends welded at an angle go to the front, the struts are angled from the front of the vehicle rearward to the *outside* of the vehicle.

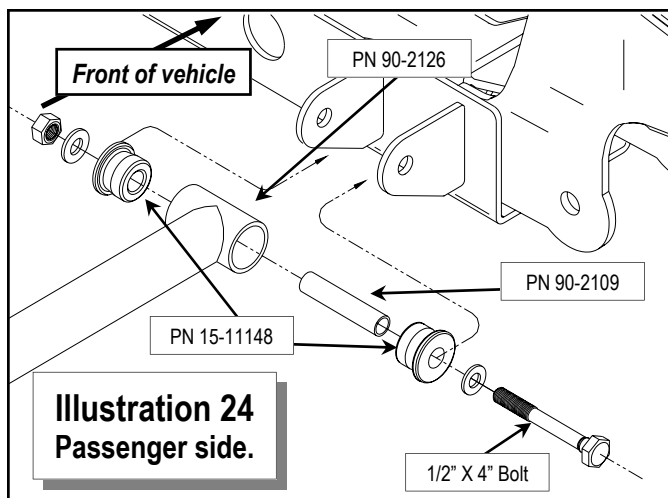

39. The type of transmission installed in your vehicle will determine the location of the mount holes for the compression struts. The mount saddles have two different holes cut into them to facilitate their placement. They must be oriented to a position that will allow the holes to be centered on the cross member. Use

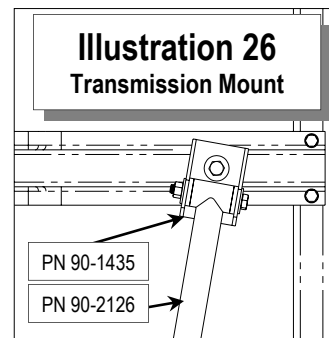
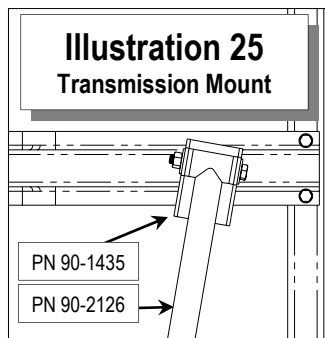

ILLUSTRATIONS 25 & 26 as a reference. Rotate the strut up to the transmission cross member and test fit the mounts until a satisfactory location is found. After you have located the position of the holes, drill them out with a 1/2" drill bit and install the saddles (PN 90-1435) with the supplied 1/2" X 1 1/4"

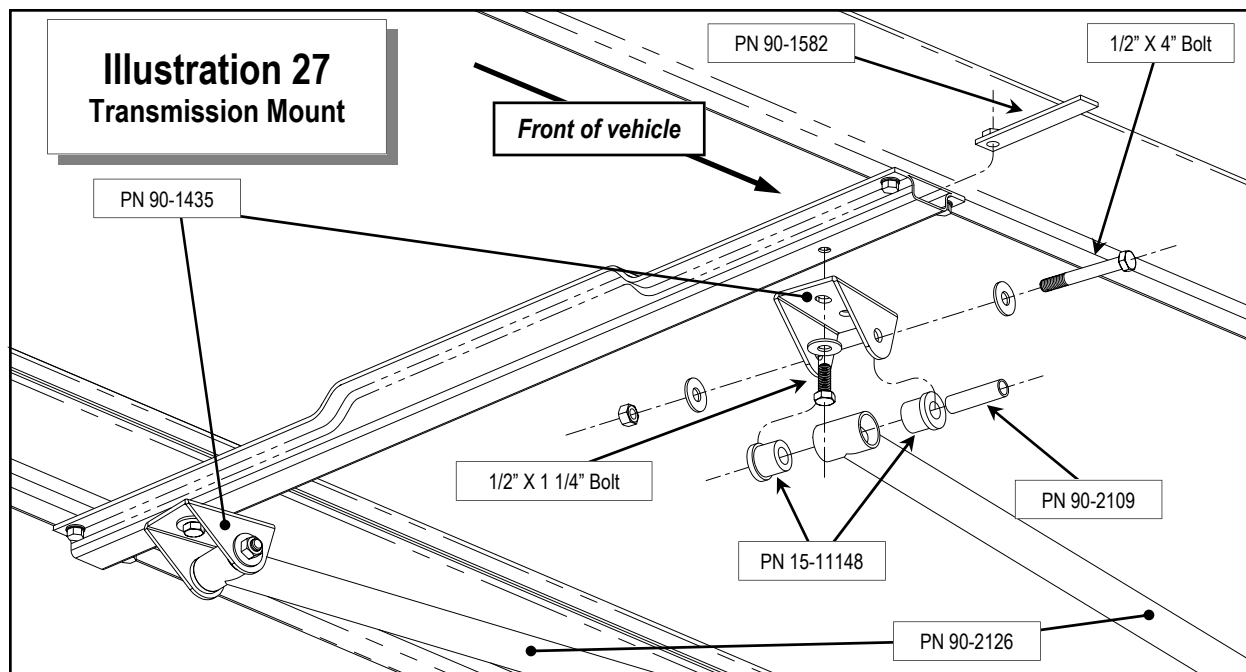

bolts, washers, and tab nuts. See **ILLUSTRATIONS 24, 26, & 27**. Rotate the struts back up and install the **1/2" X 4"** bolts supplied. Repeat this procedure for the other side. Torque the compression strut hardware to specifications.

40. With the truck still on jack stands and the suspension hanging at full extension, cycle the steering from lock to lock to check that all components have clearance and operate freely. *Pay very close attention to the ABS wiring and brake lines!*
41. Lower the truck to the ground to preload the suspension and unload the upper A-arms. Tighten the lower A-arm pivot bolts to specifications. It is necessary to rotate the upper A-arm alignment cam bolts to a neutral position (in the center of the alignment slot) and then tighten the cam bolts to specifications. This step is necessary to allow you to get to a professional alignment shop only! *Do not assume that this setting is "close enough" and skip the alignment.*
42. Torque the sway bar and sway bar link hardware until the bushings start to deflect.
43. Using the instructions included in hardware pack (90-6554), install the steering stops (PN 90-3808) at this time.

IMPORTANT!: Recheck the setting of the torsion bars after approximately 20 miles of driving.

Rear Installation

1. Raise the rear of the truck enough for the tires to clear the ground and use jack stands on the frame to support the truck. Remove the rear tires and wheels.
2. Carefully remove the OEM shock absorbers. It may be necessary to raise the differential housing slightly to facilitate their removal.
3. Remove factory brake line bracket. Attach New brake line drop bracket (PN 90-1817) to the existing hole in the frame using 5/16" hardware provided. Attach the factory brake line bracket to the new bracket using

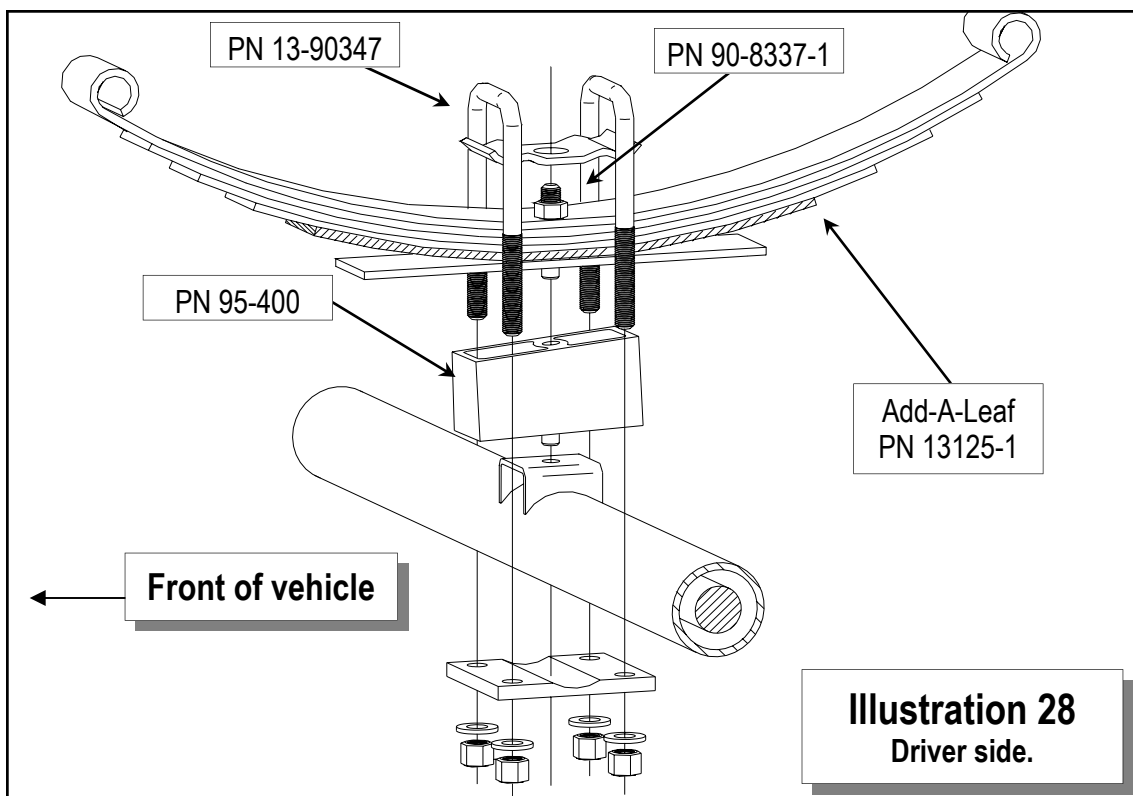

Illustration 28
Driver side.

existing hardware.

4. Remove parking brake cable bracket from rear frame rail. Attach the supplied parking brake drop bracket (**PN 90-1083**) to the stock bracket hole location then using the **5/16"** hardware provided attach the stock bracket to the new drop bracket .
5. Support the differential housing one side at a time. Remove the "U" bolts from that end and discard. Carefully lower the differential away from the OEM springs. Take careful note of the position of the factory spring packs. Remove and discard the leaf spring center bolt. Continue lowering the axle housing until there is enough room to install the add-a-leaf (**PN 13125-1**) and insert the supplied **3/8" X 4 1/2"** center bolt (**PN 90-8337-1**). Make sure that the add-a-leaf remains aligned with the OEM spring pack and torque this center bolt to specifications. Cut the center bolt off using a cutoff wheel or equivalent leaving about **1/8"** to **1/4"** of thread above the nut. It may be helpful to use C-clamps to assist in the installation of the add-a-leaf. See **ILLUSTRATION 28**.
6. If you are installing an optional traction bar kit (**PN 71120**) , follow the enclosed installation instructions. If you are not using the traction bars, install the new 4" riser block (**PN 95-400**) , short end to the front, to the mount pad on the axle housing. Raise the axle housing until the riser block hole fits around the new leaf spring center bolt.

7. Install the new "U" bolts (**PN 13-90347**) over the leaf spring assembly and using the new washers and nuts supplied along with the existing spring plates, torque the U-bolt nuts to 105 ft./lbs. See **ILLUSTRATION 27**.

8. Repeat these steps on the other side of the vehicle.
9. Install the Pro Comp shock absorbers. (**PN 329505**)
10. Remove the factory bump stops and install the bump stop extensions (**PN 90-3113 and 90-3114**) and bump stops provided (**PN 90-2144**). Use the provided **3/8" X 1 1/4"** bolts. See **ILLUSTRATION 29**.

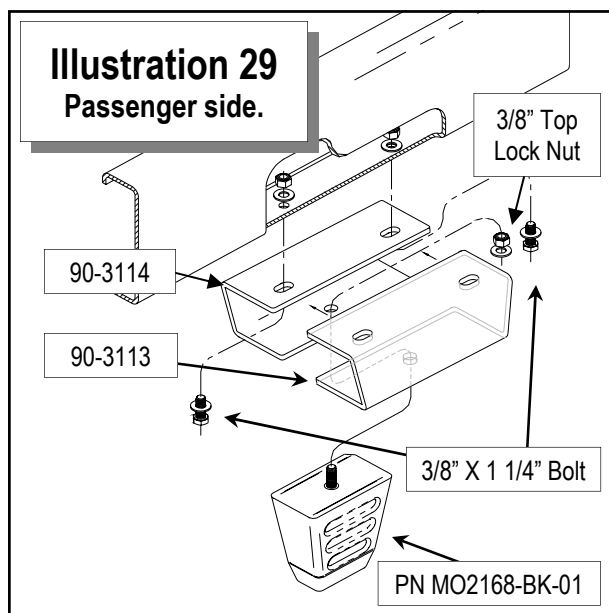

11. Install your wheels and tires and lower the vehicle to the ground.
12. After installation is complete, double check that all nuts and bolts are tight. Use the chart at the end of this document for torque specifications unless otherwise specified.
13. If new tires are installed that are more than 10% taller than original tires, the speedometer must be recalibrated for the rear wheel anti-lock brake system to function properly. Contact an authorized GM dealer for details on recalibration.
14. With the vehicle on the floor, cycle the steering from lock to lock and inspect the steering, suspension, and driveline systems for proper operation, tightness, and adequate clearance. Recheck brake hose/fittings for leaks. Be sure all hoses are long enough for safe operation.
15. Have the headlights readjusted to the proper settings.
16. Realign the front end to factory specifications. Be sure the vehicle is at the desired ride height prior to realignment.
17. Recheck suspension components after the first 100 miles and every 1,000 miles thereafter.

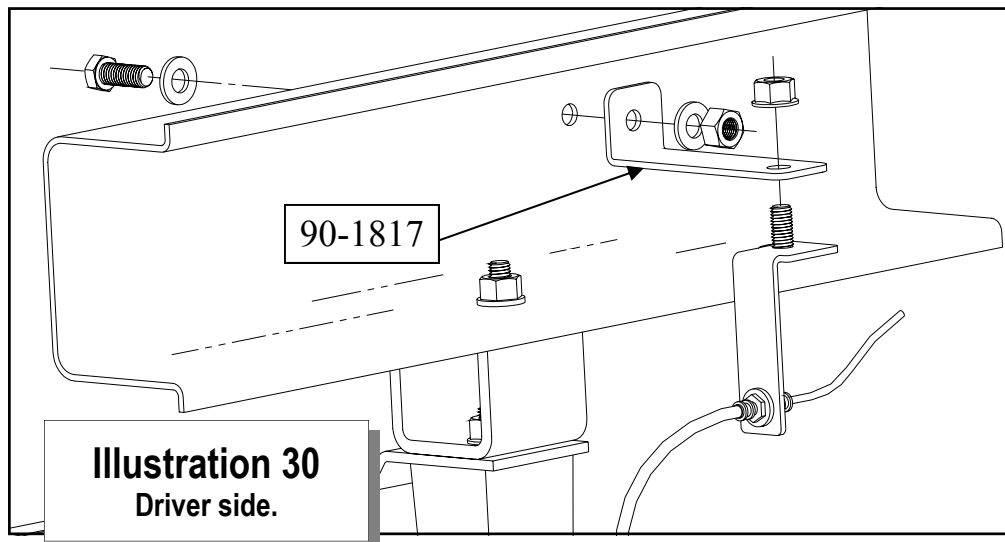

Illustration 30
Driver side.

Use this only as a guide for hardware without a called out torque specification in the instruction manual.

Bolt Torque and ID						
Decimal System			Metric System			
All Torques in Ft. Lbs. Maximums						
Bolt Size	Grade 5	Grade 8	Bolt Size	Class 9.8	Class 10.9	Class 12.9
5/16	15	20	M6	5	9	12
3/8	30	45	M8	18	23	27
7/16	45	60	M10	32	45	50
1/2	65	90	M12	55	75	90
9/16	95	130	M14	85	120	145
5/8	135	175	M16	130	165	210
3/4	185	280	M18	170	240	290

<p>1/2-13x1.75 HHCS</p> <div style="display: flex; justify-content: space-around;"> D T L X </div>	<p>Grade 5 Grade 8 (No. of Marks + 2)</p>	<p>M12-1.25x50 HHCS</p> <div style="display: flex; justify-content: space-around;"> D T L X </div>	

<p>G = Grade (Bolt Strength) D = Nominal Diameter (Inches) T = Thread Count (Threads per Inch) L = Length (Inches) X = Description (Hex Head Cap Screw)</p>	<p>P = Property Class (Bolt Strength) D = Nominal Diameter (Millimeters) T = Thread Pitch (Thread Width, mm) L = Length (Millimeters) X = Description (Hex Head Cap Screw)</p>
---	--

Notice to Owner operator, Dealer and Installer:

Vehicles that have been enhanced for off-road performance often have unique handling characteristics due to the higher center of gravity and larger tires. This vehicle may handle, react and stop differently than many passenger cars or unmodified vehicles, both on and off-road. You must drive your vehicle safely! Extreme care should always be taken to prevent vehicle rollover or loss of control, which can result in serious injury or even death. Always avoid sudden sharp turns or abrupt maneuvers and allow more time and distance for braking! Pro Comp reminds you to fasten your seat belts at all times and reduce speed! We will gladly answer any questions concerning the design, function, maintenance and correct use of our products.

Please make sure your Dealer/Installer explains and delivers all warning notices, warranty forms and instruction sheets included with Pro Comp product.

Application listings in this catalog have been carefully fit checked for each model and year denoted. However, Pro Comp reserves the right to update as necessary, without notice, and will not be held responsible for misprints, changes or variations made by vehicle manufacturers. Please call when in question regarding new model year, vehicles not listed by specific body or chassis styles or vehicles not originally distributed in the USA.

Please note that certain mechanical aspects of any suspension lift product may accelerate ordinary wear of original equipment components. Further, installation of certain Pro Comp products may void the vehicle’s factory warranty as it pertains to certain covered parts; it is the consumer’s responsibility to check with their local dealer for warranty coverage before installation of the lift.

Warranty and Return policy:

Pro Comp warrants its full line of products to be free from defects in workmanship and materials. Pro Comp’s obligation under this warranty is limited to repair or replacement, at Pro Comp’s option, of the defective product. Any and all costs of removal, installation, freight or incidental or consequential damages are expressly excluded from this warranty. Pro Comp is not responsible for damages and / or warranty of other vehicle parts related or non-related to the installation of Pro Comp product. A consumer who makes the decision to modify his vehicle with aftermarket components of any kind will assume all risk and responsibility for potential damages incurred as a result of their chosen modifications. Warranty coverage does not include consumer opinions regarding ride comfort, fitment and design. Warranty claims can be made directly with Pro Comp or at any factory authorized Pro Comp dealer.

IMPORTANT! To validate the warranty on this purchase please be sure to mail in the warranty card.

Claims not covered under warranty-

- Parts subject to normal wear, this includes bushings, bump stops, ball joints, tie rod ends and heim joints
 - Discontinued products at Pro Comp’s discretion
- Bent or dented product
- Finish after 90 days
- Leaf or coil springs used without proper bump stops
- Light bulbs
- Products with evident damage caused by abrasion or contact with other items
- Damage caused as a result of not following recommendations or requirements called out in the installation manuals
- Products used in applications other than listed in Pro Comp’s catalog
- Components or accessories used in conjunction with other manufacturer’s systems
- Tire & Wheel Warranty as per Pro Competition Tire Company policy
- Warranty claims without “Proof of Purchase”
- Pro Comp Pro Runner coil over shocks are considered a serviceable shock with a one-year warranty against leakage only. Rebuild service and replacement parts will be available and sold separately by Pro Comp. Contact Pro Comp for specific service charges.
- Pro Comp accepts no responsibility for any altered product, improper installation, lack of or improper maintenance, or improper use of our products.

E-Mail: tech@explorerprocomp.com
Website: www.explorerprocomp.com
Fax: (619) 216-1474
Ph: (619) 216-1444

PLACE
WARRANTY REGISTRATION
NUMBER
HERE: _____