

2360 Boswell Road  
Chula Vista, CA 91914  
Phone 619.216.1444  
Fax 619.216.1474  
E-Mail tech@explorerprocomp.com



## PRO COMP SUSPENSION

---

*Suspension Systems that Work!*

**Part # 52418/ 52418MX  
(April) 1999-2004 FORD 4 X 4  
SUPER DUTY F250- F350  
6 1/2" SUSPENSION SYSTEM**

*Not for use on vehicles made prior to 04-01-1999!*

This document contains very important information that includes warranty information and instructions for resolving problems you may encounter. Please keep it in the vehicle as a permanent record.

**Box 1 of 3-PN 52418-1**

Part #	Description	Qty.	Illus.	Page
90-1318	Track Rod Mount	1	4	6
MO-2168-BK-01	Bump Stops	2	3	6
13-90190	5/8"x3 1/2"x14-1/2" Round U-bolt	4	5	8
13-90530	9/16" x 3 1/8" x 11 1/4" Oval U-Bolt	4	-	-
90-1114	Sway Bar Mount Plate	2	1	4
90-6040	Hardware Pack Containing:	1	-	-
70-0501501800	1/2" x 1 1/2" USS Gd 8 Hex Bolt	2	1	4
72-05000100815	1/2" USS Gd 8 USS Stover Nut	2	1	4
73-05000042	1/2" USS Hardened Flat Washer	4	1	4
90-6042	Part Pack Containing:	1	-	-
45359	5/8" Rubber Hourglass Bushing	4	2	5
60859H	5/8" ODx12 MM IDx1.480" Sleeve	4	2	5
90-6154	Hardware Pack Containing:	1	-	-
90-1216	Load Washer	4	4	6
72-01015008812	10 mm-1.5 Nut (Center Bolt Nut)	4	5	8

**Box 2 of 3-PN 52418-2**

90-3113	Bump Stop Spacer	2	4	6
90-3114	Bump Stop Spacer	2	4	6
90-2179	Sway Bar Links	2	1	4
95-150F	1 1/2" Aluminum Block	2	5	8
13-90356	9/16"x3 1/8"x9-1/4" Square U-bolt	4	-	-
FD500-1	Pitman Arm	1	-	-
90-6041	Hardware Pack Containing:	1	-	-
20-65302	Hardware Pack 9/16" Highnuts & Washers	1	5	8
20-65471	Hardware Pack 5/8" Highnuts & Washers	1	5	8
70-0502751800	1/2"x2 3/4" USS Gd 8 Hex Bolt	1	4	6
71-1207017508800	12MMx70MM 1.75 Pitch Gd 8.8 Hex Bolt	2	2	5
72-01217508812	12MMx1.75 Pitch Nyloc Nut	2	2	5
72-03700100512	3/8" USS Gd 5 Nyloc Nut	2	3	6
72-05000100816	1/2" USS Gd 8 Stover Nut	1	4	6
73-03700032	3/8" USS Flat Washer	2	3	6
73-05000032	1/2" USS Flat Washer	2	4	6
73-05000042	1/2" USS Hardened Flat Washer	2	4	6
90-6337	Hardware Pack Containing:	1	-	-
97-165	10MMx165MM SUPER DUTY CENTER PIN	2	5	8

**Box 3 of 3-PN 52418-3**

929508	Front Shocks	2	-	-
932008	Rear Shocks	2	-	-

**(OR) Box 3 of 3-PN 52418MX-3**

MX6121	MX6 Front Shocks	2	-	-
MX6018	MX6 Rear Shocks	2	-	-

**The following parts are used in conjunction with this kit and must be purchased separately.**

22610	FRONT LEAF SPRINGS	2		
22415	REAR LEAF SPRINGS	2	5	8

**Special Tools:**

Pitman Puller                      Snap-On PN CJ1119B

**Optional Equipment Available from your PRO COMP Distributor!**

DRIVESHAFT ALIGNMENT KIT	PN 52480
FRONT DUAL SHOCK KITS	PN 52410
TRACTION BARS	PN 72400
LIGHT BARS	PN 24400 (BLACK), 24400G (GREY)
STEERING STABILIZERS	PN 222570

**ALSO, CHECK OUT OUR OUTSTANDING SELECTION OF PRO COMP TIRES TO COMPLIMENT YOUR NEW INSTALLATION!**

## Introduction:

- ◆ **This installation requires a professional mechanic!**
- ◆ We recommend that you have access to a Ford service manual for your vehicle to assist in the disassembly and reassembly of your vehicle. It contains a wealth of detailed information.
- ◆ Prior to installation, carefully inspect the vehicle's steering and driveline systems paying close attention to the tie rod ends, ball joints, wheel bearing preload, pitman and idler arm. Additionally, check steering-to-frame and suspension-to-frame attaching points for stress cracks. The overall vehicle must be in excellent working condition. Repair or replace all worn or damaged parts!
- ◆ Read the instructions carefully and study the illustrations before attempting installation! You may save yourself a lot of extra work.
- ◆ Check the parts and hardware against the parts list to assure that your kit is complete. Separating parts according to the areas where they will be used and placing the hardware with the brackets before you begin will save installation time.
- ◆ Check the special equipment list and ensure the availability of these tools.
- ◆ Secure and properly block vehicle prior to beginning installation.
- ◆ ***ALWAYS*** wear safety glasses when using power tools or working under the vehicle!
- ◆ Use caution when cutting is required under the vehicle. The factory undercoating is flammable. Take appropriate precautions. **Have a fire extinguisher close at hand.**
- ◆ Foot pound torque readings are listed on the Torque Specifications chart at the end of the instructions. These are to be used unless specifically directed otherwise. Apply thread lock-retaining compound where specified.
- ◆ ***Please note that while every effort is made to ensure that the installation of your Pro Comp lift kit is a positive experience, variations in construction and assembly in the vehicle manufacturing process will virtually ensure that some parts may seem difficult to install. Additionally, the current trend in manufacturing of vehicles results in a frame that is highly flexible and may shift slightly on disassembly prior to installation. The use of pry bars and tapered punches for alignment is considered normal and usually does not indicate a faulty product. However, if you are uncertain about some aspect of the installation process, please feel free to call our tech support department at the number listed on the cover page. We do not recommend that you modify the Pro Comp parts in any way as this will void any warranty expressed or implied by the Pro Comp Suspension company.***

## Please Note:

- ⇒ Front suspension and head light realignment is necessary!
- ⇒ Speedometer and ABS recalibration will be necessary if larger tires (10% more than stock diameter) are installed.
- ⇒ **IT IS ADVISABLE THAT YOU HAVE HELP AVAILABLE WHEN INSTALLING THIS KIT. SOME COMPONENTS ARE HEAVY AND AWKWARD. AN ADDITIONAL SET OF HANDS IS GOOD INSURANCE AGAINST INJURY!**

## Important!

Due to differences in manufacturing, dimensions and inflated measurements, tire and wheel combinations should be test fit prior to installation. Tire and wheel choice is crucial in assuring proper fit, performance, and the safety of your Pro Comp equipped vehicle. For this application, we recommend a wheel not to exceed 8" in width with a minimum backspacing of 4" must be used. Additionally, a quality tire of radial design, not exceeding 35" tall X 12.5" wide is also recommended. Please note that the use of a 35" X 12.5" tire may require fender modification. Violation of these recommendations will not be endorsed as acceptable by Pro Comp Suspension and will void any and all warranties either written or implied.

### Before You Begin:

- ⇒ Read the instructions and study the illustrations before attempting the installation.
- ⇒ Separation the parts according to the areas where they will be used and placing the hardware with the brackets before you begin will save installation time.
- ⇒ Check the parts and hardware against the parts list to assure that your kit is complete.
- ⇒ ALWAYS wear safety glasses when using power tools or working beneath your vehicle.
- ⇒ A pitman arm removal tool and tie rod separating tool are required to perform the installation. See the special tools at the bottom of page 2.
- ⇒ Always use NEW cotter pins on re-assembly! (These items are NOT supplied)

### Front Installation:

1. Position your vehicle on a smooth, flat, hard surface (i.e. concrete or asphalt) and block the rear tires. Set the park brake.
2. Measure and record the distance from the center of each wheel to the top of its fender opening. Record below.

LF: \_\_\_\_\_ RF: \_\_\_\_\_

LR: \_\_\_\_\_ RR: \_\_\_\_\_

3. Remove the track rod bolt on the driver side at the frame mount. Save this hardware for re-use.
4. Place the vehicle in neutral. Place your floor jack under the front axle and raise the vehicle. Place jack stands under the frame rails behind the front leaf spring shackles and lower the frame onto the stands. Remove the jack and place the vehicle back in gear, set the emergency brake, and place blocks both in front and behind the rear wheels.

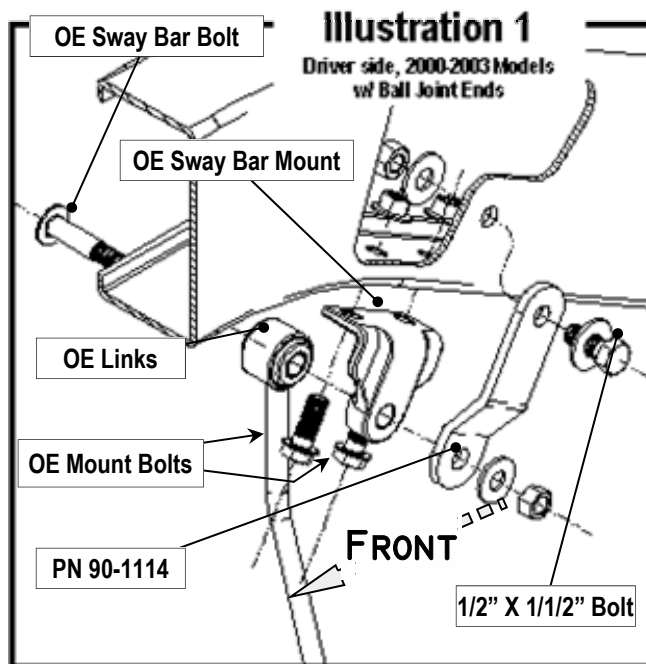

5. Remove the sway bar links on both sides of the vehicle.
6. Remove the sway bar mounts from the inside of the frame and reposition them on the under-

side of the frame as shown in **Illustration 1**. Re-use the OE mount hardware on 2000 - 2003 models.

7. Remove the bumper extension from below and behind the bumper. This extension covers the ends of the spring ends.
8. Loosen the U-bolts on the passenger side of the vehicle. This will make installation of the new spring and U-bolts easier.
9. On the driver side, raise the front axle slightly with your floor jack. Remove the shock absorber and discard the shock. Save the hardware for re-use.
10. Remove the U-bolts from the axle.
11. Lower the axle on the driver side to clear the spring and remove the spring from the truck.

**Note:** You will need to remove the lower AC condenser mount to perform the next step. This bracket prevents the complete removal of the front spring mount bolt. Remove the AC mount on the side you are working on **ONLY**.

**Tech Tip:** Factory spring bolts are secured with thread lock<sup>®</sup> which makes removal difficult. By warming the nut with a propane torch to approximately 300° Fahrenheit, the Loctite<sup>®</sup> will release allowing easier removal with hand tools.

### **Important:**

The Pro Comp front leaf spring (PN 22610) is supplied with a 1/2" thick spacer block on the bottom of the spring pack. This spacer is for the **diesel application only** and must be removed for vehicles with gasoline engines. To remove the spacer, hold the spring pack together with C-clamps and remove the center pin nut. Remove the center pin and spacer. Reinstall the center pin. Discard the old nut and replace it with the new nut provided in parts pack 90-6154. Torque the nut to 40 ft. lbs.

**NOTE:** Top spring plate center hole needs to be drilled out to 3/4" to clear nut from pack 90-6154.

**ALWAYS have a fire extinguisher handy whenever using an open flame on or near ANY vehicle!**

12. Install the front springs (PN 22610) into the stock mounts using the factory hardware. Do not tighten this hardware at this time.
13. Replace the AC condenser mount before you remove the mount on the opposite side!
14. Raise the axle to the spring and secure it with the new U-bolts, 9/16" Hi-nuts (PN 20-65302) and washers supplied. Again do not tighten this hardware at this time.

**Note:** Two sets of 9/16" U-bolts are supplied. PN 13-90530 (round bend) and PN 13-90356 ("square bend") Use the new U-bolts that have the same bend configuration as your OE U-bolts.

---

### **Repeat steps 6 thru 14 on the passenger side**

---

15. Install the new shock (PN 929508) and torque the mounting hardware to 60 ft. lbs.

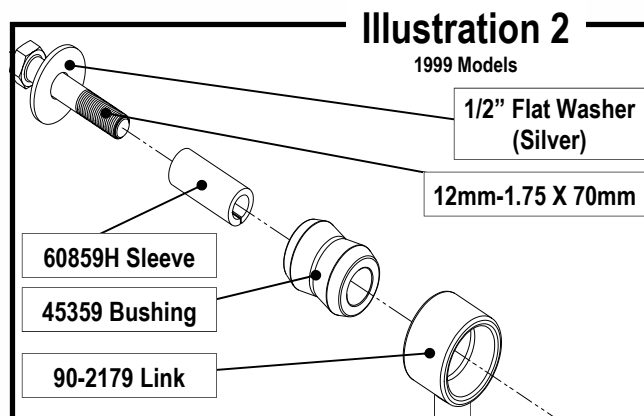

16. On 2000 and newer models, re-use the factory sway bar links and re-assemble the sway bar linkage. See **Illustration 1**.

**Note:** On 1999 models, assemble the new sway bar links (PN 90-2179) using the bushings (PN 45359) and sleeves (PN 60859H) supplied in parts pack 90-6042 as seen in **Illustration 2**. Install each side using one new 12mm X 70mm bolt from hardware pack 90-6041 with one 1/2" washer (silver) and one of the OE bolts previously removed. Torque this hardware to 55 ft. lbs.

17. Remove the cast track bar mount on the driver

side. Save the bolts and pal nuts for re-use.

18. Use a tie rod separator and a pitman arm puller (See special tools section on page 2) to remove the OE pitman arm.

**Important:** No matter how much you are tempted, **DO NOT** use a torch to heat the pitman arm to remove it! The arm is very close to the steering box seals and you will probably burn the seals before the pitman arm comes loose. Use the proper tools!

19. When installing your new pitman arm you will need to first measure the sector shaft coming out of the steering box. If the diameter of the sector shaft above the splines is 1.3125 inches, install the FD 400 pitman arm. If the diameter of the sector shaft above the splines is 1.375 inches, install the FD 500 pitman arm. Install the pitman arm and Hand tighten sector shaft nut then tighten only with a torque wrench. Torque sector shaft nut to 185 ft. lbs.

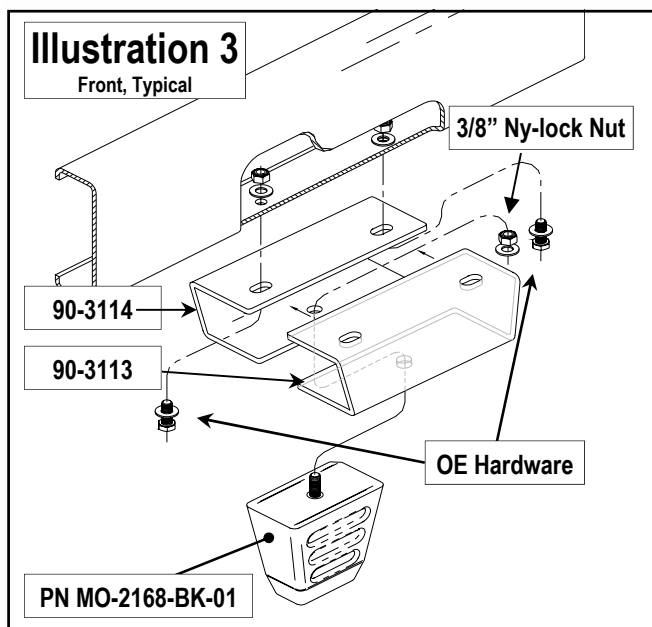

20. Install the drag link to the pitman arm and torque this fastener to 60 ft. lbs.
21. Remove the bump stops from the frame flange. Position the bump stop spacers (PN 90-3113 and 90-3114) in the center of the lower frame flange. Secure the spacer block with the factory mounting hardware. Install the new bump stops (PN MO-2168-BK-01) with the 3/8"

Ny-lock nuts from hardware pack 90-6041.

See Illustration 3.

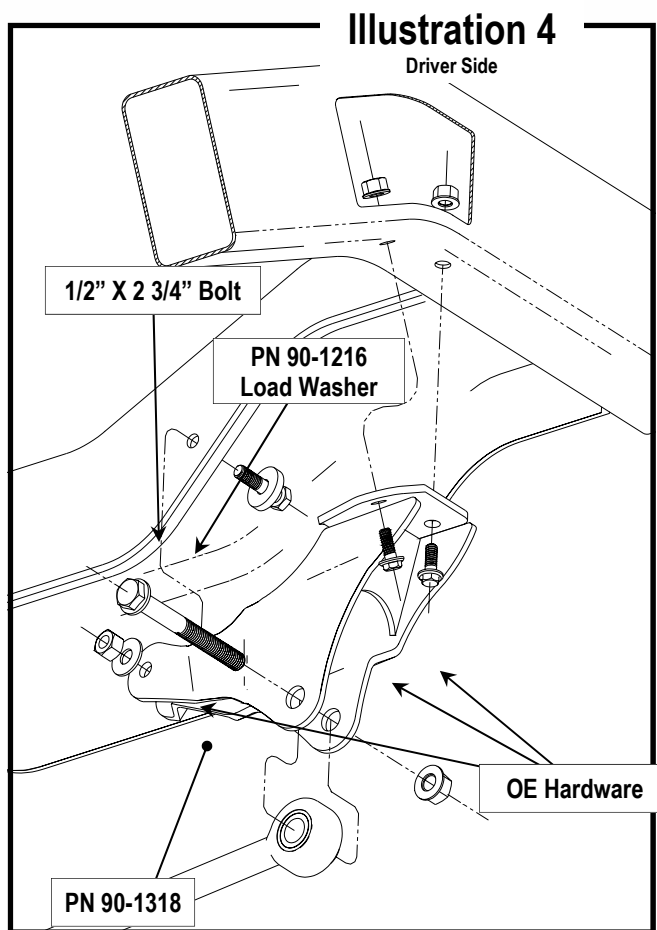

22. Install the Pro Comp track rod mount (PN 90-1318). Use the existing bolts and pal nuts on the frame and use the new 1/2" X 2 3/4" bolt from hardware pack 90-6041 with the load washer (PN 90-1216) under the head of the bolt, through the cross member. Install the 1/2" bolt from the rear of the vehicle. The load washer, when properly installed, will be between the head of the bolt and the cross member as shown in Illustration 4. Install a flat washer on the outside of the track bracket under the 1/2" nut. Torque this bolt to 85 ft. lbs.
23. Re-install the lower bumper extension.
24. Install the wheels and set the vehicle on the ground.
25. Tighten the 18mm spring mount bolts to 130 ft. lbs. Tighten the 16mm spring mount bolts to 115 ft. lbs. Tighten the 9/16" U-bolts to 100 ft. lbs.

NOTE: If the center pin on the new spring is too tall it will not allow the spring mount plate to sit flat. If this is the case this bolt head should be ground down a no more than .125" so that the mount plate sits flush on the spring. Failure to do this will cause the spring to loosen up.

26. Install the track rod bolt into the new mount. Torque this to 135 ft. lbs.

## Rear Installation:

1. Block the front tires and raise the rear of the vehicle. Support the frame with jack stands forward of the rear springs.
2. Remove the wheels and tires.
3. Remove the shocks on both sides of the vehicle. It may be necessary that you slightly raise the axle to unload the shocks for removal.
4. Support the rear axle with a floor jack and remove the U-bolts on the driver side. Loosen the U-bolts on the passenger side.
5. Lower the rear axle and remove the factory block and rear leaf spring from the driver side only at this time.
6. Use **Illustration 5** on the next page, and the notes\* below as a reference. The heavy factory leaf on the bottom of the leaf pack and the upper overload spring must be removed and used on the new Pro Comp rear leaf spring. Again, use C-clamps to hold the leaves together. Make note of the direction of the arch and the offset of the centering hole (long end forward/back etc.). Remove the OE center bolts and separate the spring pack.
7. Install the heavy leaf on the bottom of the new Pro Comp spring pack (**PN 22415**). Install the overload with the spacer at the top of the Pro Comp spring, use the new center bolt from pack (**90-6337**) if needed, again use C-clamps to assist in the assembly. On reassembly use a new lock nut from hardware pack **90-6154**.

**NOTE: Top spring plate center hole needs to be drilled out to 3/4" to clear nut from**

**Note:** You may find that having someone inside the vehicle and moving the steering wheel from side to side will aid in the alignment of the track rod. **DO NOT** start the engine for this! You only have to move it enough to line the holes up on the track bar mount. \*\*\*Trim 1" excess off track rod bolt after it is installed to protect bolt from contacting differential cover or pitman arm.

### Please Note:

- \* Vehicles equipped with a 4" factory block under the rear leaf will retain only the factory 4" block between the axle pad and the replacement leaf springs.
- \* Vehicles equipped from the factory with a 4" block may also have a single overload on the top of the spring pack. Since these vehicles do not require the 1 1/2" aluminum block for lift, the block can be used under the overload to raise it closer to the contact pads.
- \* Vehicles equipped with a 2 1/2" factory block will retain the factory 2 1/2" block and install the 1 1/2" (PN 95-150F) aluminum block supplied for a total of 4" between the axle pad and the replacement leaf spring.

**pack 90-6154.**

8. Install the spring pack to the hangers using the factory hardware. Do not tighten at this time.
9. Install the block (**PN 90-150F**) if needed on the axle pads and raise the axle to the spring and secure with the 5/8" U-bolts (**PN 13-90190**) 5/8" Hi-nuts (**PN 20-65471**) and washers supplied. Do not tighten these bolts at this time.
10. Install your new Pro Comp shocks (**PN 932008**) and torque this hardware to 60 ft. lbs.

**Illustration 5**  
Passenger Side

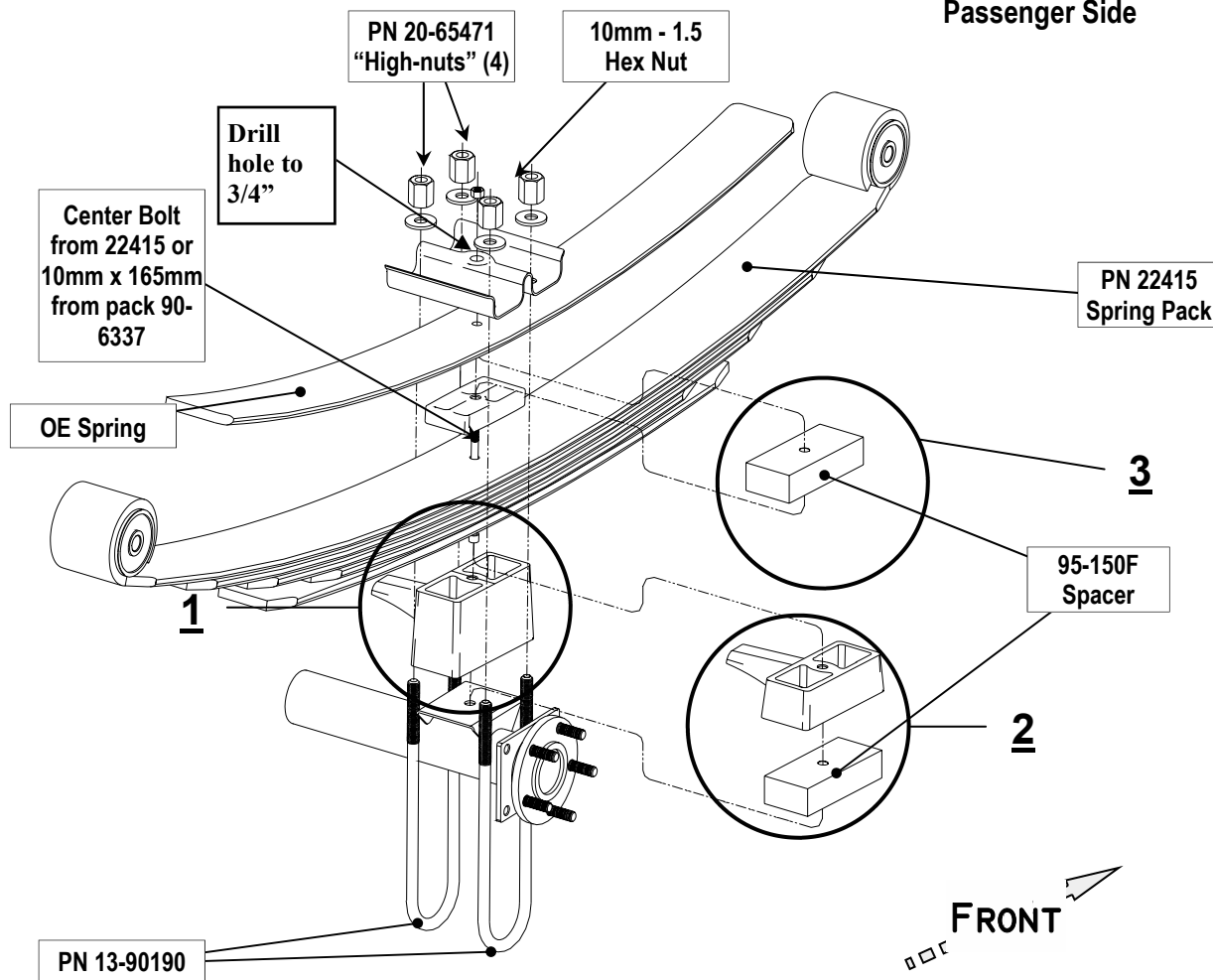

### Rear Spacer Options

1. 4" block ONLY  
OR
2. 2 1/2" block and 1 1/2" spacer, PN 95-150F

**THIS OPTION AVAILABLE ONLY WITH THE OE 4" BLOCK AND OVERLOAD SPRING!**

3. 4" block with 1 1/2" spacer, PN 95-150F added to lift the overload.

**SEE INSET BOX AFTER INSTRUCTION 9.**

11. Tighten the U-bolts to 115 ft. lbs.

---

**Repeat steps 4 thru 11 on the passenger side**

---

12. Reinstall the wheels and tires and lower the vehicle to the ground.
13. Torque the spring mounts at this time. The 16mm bolts are torqued to 115 ft. lbs. and the 18mm bolts are torqued to 130 ft. lbs. Torque

the 5/8" U-bolts to 115 ft. lbs.

14. Re-check the wheel lug torque on all four wheels at this time.
15. Re-check *all* hardware (both the front and the rear) for proper installation and torque!!
16. If you wish, you may trim the excess u-bolt thread length. If you do this you should leave approximately one inch of thread exposed after the U-bolts are torqued.

⇒ Have your headlights adjusted.

⇒ Recheck all hardware for tightness after the first 100 miles AND after any off road use.

---

Use this only as a guide for hardware without a called out torque specification in the instruction manual.

<b>Bolt Torque and ID</b>						
<b>Decimal System</b>			<b>Metric System</b>			
All Torques in Ft. Lbs. Maximums						
Bolt Size	Grade 5	Grade 8	Bolt Size	Class 9.8	Class 10.9	Class 12.9
5/16	15	20	M6	5	9	12
3/8	30	45	M8	18	23	27
7/16	45	60	M10	32	45	50
1/2	65	90	M12	55	75	90
9/16	95	130	M14	85	120	145
5/8	135	175	M16	130	165	210
3/4	185	280	M18	170	240	290

<p>1/2-13x1.75 HHCS</p> <p> </p>	<p>M12-1.25x50 HHCS</p> <p> </p>
<p><b>G = Grade (Bolt Strength)</b>  <b>D = Nominal Diameter (Inches)</b>  <b>T = Thread Count (Threads per Inch)</b>  <b>L = Length (Inches)</b>  <b>X = Description (Hex Head Cap Screw)</b></p>	<p><b>P = Property Class (Bolt Strength)</b>  <b>D = Nominal Diameter (Millimeters)</b>  <b>T = Thread Pitch (Thread Width, mm)</b>  <b>L = Length (Millimeters)</b>  <b>X = Description (Hex Head Cap Screw)</b></p>

**Notice to Owner operator, Dealer and Installer:**

Vehicles that have been enhanced for off-road performance often have unique handling characteristics due to the higher center of gravity and larger tires. This vehicle may handle, react and stop differently than many passenger cars or unmodified vehicles, both on and off-road. You must drive your vehicle safely! Extreme care should always be taken to prevent vehicle rollover or loss of control, which can result in serious injury or even death. Always avoid sudden sharp turns or abrupt maneuvers and allow more time and distance for braking! Pro Comp reminds you to fasten your seat belts at all times and reduce speed! We will gladly answer any questions concerning the design, function, maintenance and correct use of our products.

**Please make sure your Dealer/Installer explains and delivers all warning notices, warranty forms and instruction sheets included with Pro Comp product.**

Application listings in this catalog have been carefully fit checked for each model and year denoted. However, Pro Comp reserves the right to update as necessary, without notice, and will not be held responsible for misprints, changes or variations made by vehicle manufacturers. Please call when in question regarding new model year, vehicles not listed by specific body or chassis styles or vehicles not originally distributed in the USA.

**Please note that certain mechanical aspects of any suspension lift product may accelerate ordinary wear of original equipment components.** Further, installation of certain Pro Comp products may void the vehicle’s factory warranty as it pertains to certain covered parts; it is the consumer’s responsibility to check with their local dealer for warranty coverage before installation of the lift.

**Warranty and Return policy:**

Pro Comp warrants its full line of products to be free from defects in workmanship and materials. Pro Comp’s obligation under this warranty is limited to repair or replacement, at Pro Comp’s option, of the defective product. Any and all costs of removal, installation, freight or incidental or consequential damages are expressly excluded from this warranty. Pro Comp is not responsible for damages and / or warranty of other vehicle parts related or non-related to the installation of Pro Comp product. A consumer who makes the decision to modify his vehicle with aftermarket components of any kind will assume all risk and responsibility for potential damages incurred as a result of their chosen modifications. Warranty coverage does not include consumer opinions regarding ride comfort, fitment and design. Warranty claims can be made directly with Pro Comp or at any factory authorized Pro Comp dealer.

**IMPORTANT!** To validate the warranty on this purchase please be sure to mail in the warranty card.

**Claims not covered under warranty-**

- Parts subject to normal wear, this includes bushings, bump stops, ball joints, tie rod ends and heim joints
  - Discontinued products at Pro Comp’s discretion
- Bent or dented product
- Finish after 90 days
- Leaf or coil springs used without proper bump stops
- Light bulbs
- Products with evident damage caused by abrasion or contact with other items
- Damage caused as a result of not following recommendations or requirements called out in the installation manuals
- Products used in applications other than listed in Pro Comp’s catalog
- Components or accessories used in conjunction with other manufacturer’s systems
- Tire & Wheel Warranty as per Pro Competition Tire Company policy
- Warranty claims without “Proof of Purchase”
- Pro Comp Pro Runner coil over shocks are considered a serviceable shock with a one-year warranty against leakage only. Rebuild service and replacement parts will be available and sold separately by Pro Comp. Contact Pro Comp for specific service charges.
- Pro Comp accepts no responsibility for any altered product, improper installation, lack of or improper maintenance, or improper use of our products.

E-Mail: [tech@explorerprocomp.com](mailto:tech@explorerprocomp.com)  
Website: [www.explorerprocomp.com](http://www.explorerprocomp.com)  
Fax: (619) 216-1474  
Ph: (619) 216-1444

<b><u>PLACE</u></b>
<b><u>WARRANTY REGISTRATION</u></b>
<b><u>NUMBER</u></b>
<b>HERE:</b> _____