

2360 Boswell Road
Chula Vista, CA 91914
Phone 619.216.1444
Fax 619.216.1474
E-Mail tech@explorerprocomp.com



PRO COMP SUSPENSION

Suspension Systems that Work!

**Part # 55499
'97-'02 4WD Jeep
Wrangler TJ
Stage II 3" to 4" Lift
Designed To Fit Vehicles
w/ Power Steering Only
Now Manufactured With
Chromolly Arms**

This document contains very important information that includes warranty information and instructions for resolving problems you may encounter. Please keep it in the vehicle as a permanent record.

Box 1-PN 55499-1

Part #	Description	Qty	Illus.
90-2058	Lower Control Arm	4	6,7
90-2064	Crosslink, Track Bar Brace 25.5"	1	8,9,10
90-1011	Bracket, Track Bar Mount (Rear)	1	20,21
90-2065	Brace, Secondary Support 23.75"	1	8,9,10
90-2008	Sway Bar Link (Front)	2	14,15
90-2009	Sway Bar Link (Rear)	2	19
90-4002	Bumpstop Pad (Front)	2	12
90-4003	Bumpstop Extension (Rear)	2	18
90-6045	Hardware Pack Containing:		
90-2002	Transfer Case Pack Spacer, Conical	6	16
90-2003	Spacer, Transfer Case	6	16
90-6046	Hardware Pack & Sleeves		
45359	Bushing, (Rubber) Hour Glass	4	14,19
600001	5/8" Urethane Bushing .562 I.D.	4	
60859H	Sleeve, 5/8" x 12mm x 1.48" Lg.	2	14
61150	Sleeve, 5/8" x 3/8" x 1.48" Lg.	2	14
90-6047	Hardware Pack Containing:		
90-1003	Shifter Drop Bracket	2	17A
90-1122	Tab, Track Bar Mount (Pass.)	2	9
90-2010	Sleeve, 7/8" x 1.60" Lg.	1	20
90-2014	Spacer, .750" x .120 Wall x .250"	1	9
90-2022	Sleeve, 3/4" x .87" Lg.	1	10
90-2071	Sleeve, 3/4" x 3.34" Lg.	1	9
JM8	Rod End w/ Nut, 1/2"-20 Right Hand	2	8
JML8	Rod End w/ Nut, 1/2"-20 Left Hand	2	8
90-6048	Hardware Pack Containing:		
15-11255	Bushing, Tapered (Red)	16	6
90-2310	Sleeve	8	6
90-6059	Hardware Pack Containing:		
90-1010	Bracket, Sway Bar Front Mount	2	15
90-1121	Frame Brace Mount (Block Mount)	1	9,10
90-1125	Track Bar Mount (Front)	1	10
90-6062	Hardware Pack Containing:		
70-0503001500	1/2" x 3" USS Gr. 5 Hex Bolt	7	
71-1006515008800	10mm x 1.50 x 65mm Hex Bolt	2	
70-0372501520	3/8" x 2" Self Tapping Hex Bolt	2	
70-0372501500	3/8" x 2 1/2" USS Gr. 5 Hex Bolt	2	
70-0371501500	3/8" x 1 1/2" USS Gr. 5 Hex Bolt	2	
70-0371001504	3/8" x 1" USS Gr. 5 Hex Bolt	1	
70-0311001500	5/16" x 1" USS Gr. 5 Hex Bolt	3	
73-05000030	1/2" SAE Flat Washer	8	
73-05000036	1/2" Split Lock Washer	6	
73-03700030	3/8" SAE Flat Washer	12	
73-01000036	10mm Split Lock Washer	12	
73-03100030	5/16" SAE Flat Washer	6	

72-05000100512	1/2" USS Gr. 5 Nyloc Nut	1	
72-03700100512	3/8" USS Gr. 5 Nyloc Nut	5	
72-03100100512	5/16" USS Gr. 5 Nyloc Nut	3	
71-0602010010909	6mm x 1.0 x 20mm Button Head	4	
73-00600040	6mm Flat Washer	8	
72-00610008812	6mm x 1.0 Nyloc Nut	4	
90-6066	Hardware Pack Containing:		
70-0562751800	9/16" x 2 3/4" USS Gr. 8 Hex Bolt	1	
70-050751800	1/2" x 7 1/2" USS Gr. 8 Hex Bolt	1	
70-0502751806	1/2" x 2 3/4" USS Ctr. Sunk Allen Bolt	2	
70-0502501800	1/2" x 2 1/2" USS Gr. 8 Hex Bolt	1	
73-05600042	9/16" USS Hardened Flat Washer	1	
73-05000038	1/2" Flat Washer A.N.		
73-05000030	1/2" SAE Flat Washer	4	
72-05600100816	9/16" USS Gr. C Top Lock Nut	1	
72-05000100816	1/2" USS Gr. C Top Lock Nut	4	
YJ400	Pitman Arm (Power Steering Only)	1	11

FOLLOWING PARTS ARE USED IN CONJUNCTION WITH THIS KIT. THEY ARE NOT INCLUDED AND MUST BE ORDERED SEPARATELY.

324515	Shock Absorbers (Front)	2	13
324509	Shock Absorbers (Rear)	2	
55497	Coil Springs, pair (Front)	1	13
55498	Coil Springs, pair (Rear)	1	

OPTIONAL PRODUCT OFFERED BY PRO COMP FOR YOUR JEEP WRANGLER

55496	Winch Spacer, 1" (Front) - Pair	1	
7450	Stainless Steel Brake Line	1	
219200	Steering Stabilizer	1	
20-65225	Rear Pinion Adjustment Cams	1	

PRO COMP NOW OFFERS A FULL LINE OF ALL TERRAIN & MUD TERRAIN TIRES. CALL YOUR LOCAL DEALER FOR DETAILS.

PLEASE NOTE:

Due to differences in manufacturing, dimensions and inflated measurements, tire and wheel combinations should be test fit prior to installation. Tire and wheel choice is crucial in assuring proper fit, performance, and the safety of your Pro Comp equipped vehicle. For this application, we recommend a wheel not to exceed 10" in width with a minimum backspacing of 3.25" must be used. Additionally, quality tire of radial design, not exceeding 33" tall X 12.5" wide is also recommended. Please note that the use of a 33" X 12.5" tire may require fender modification. Violation of these recommendations will not be endorsed as acceptable by Pro Comp Suspension and will void any and all warranties either written or implied.

Introduction:

- ◆ **This installation requires a professional mechanic!**
- ◆ We recommend that you have access to a factory service manual for your vehicle to assist in the disassembly and reassembly of your vehicle. It contains a wealth of detailed information.
- ◆ Prior to installation, carefully inspect the vehicle's steering and driveline systems paying close attention to the tie rod ends, ball joints, wheel bearing preload, pitman and idler arm. Additionally, check steering-to-frame and suspension-to-frame attaching points for stress cracks. The overall vehicle must be in excellent working condition. Repair or replace all worn or damaged parts!
- ◆ Read the instructions carefully and study the illustrations before attempting installation! You may save yourself a lot of extra work.
- ◆ Check the parts and hardware against the parts list to assure that your kit is complete. Separating parts according to the areas where they will be used and placing the hardware with the brackets before you begin will save installation time.
- ◆ Check the special equipment list and ensure the availability of these tools.
- ◆ Secure and properly block vehicle prior to beginning installation.
- ◆ **ALWAYS** wear safety glasses when using power tools or working under the vehicle!
- ◆ Use caution when cutting is required under the vehicle. The factory undercoating is flammable. Take appropriate precautions. Have a fire extinguisher close at hand.
- ◆ Foot pound torque readings are listed on the Torque Specifications chart at the end of the instructions. These are to be used unless specifically directed otherwise. Apply thread lock retaining compound where specified.
- ◆ ***Please note that while every effort is made to ensure that the installation of your Pro Comp lift kit is a positive experience, variations in construction and assembly in the vehicle manufacturing process will virtually ensure that some parts may seem difficult to install. Additionally, the current trend in manufacturing of vehicles results in a frame that is highly flexible and may shift slightly on disassembly prior to installation. The use of pry bars and tapered punches for alignment is considered normal and usually does not indicate a faulty product. However, if you are uncertain about some aspect of the installation process, please feel free to call our tech support department at the number listed on the cover page. We do not recommend that you modify the Pro Comp parts in any way as this will void any warranty expressed or implied by the Pro Comp Suspension company.***

There are two special tools needed during disassembly and installation. They may be purchased through your authorized Jeep dealer.

- 1) **Puller - C-3894-Z**
- 2) **Pitman arm remover - C-4150A**

Installation Instructions:

- 1) Raise and support vehicle with jack stands. Support axle with a floor jack. Remove wheels and tires.
- 2) Place reference marks (as shown in ILLUSTRATION 1) on front drive shafts and axle. Disconnect the front drive shaft from axle.

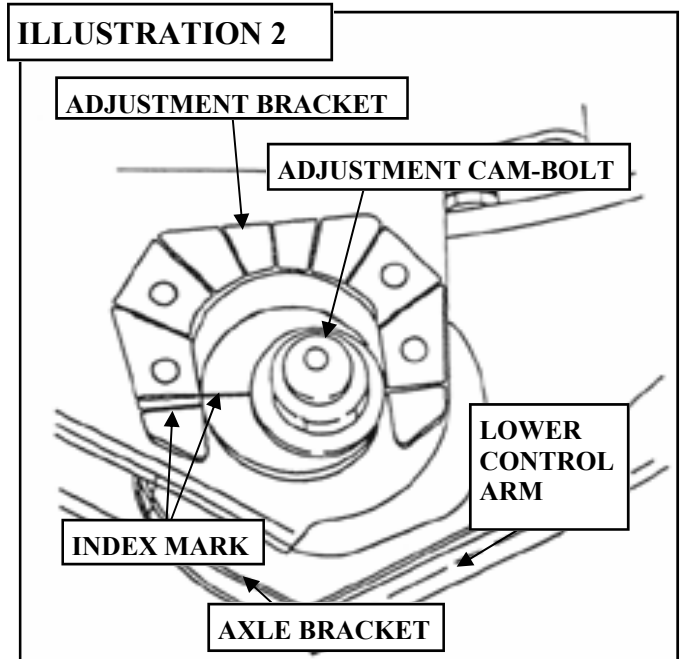
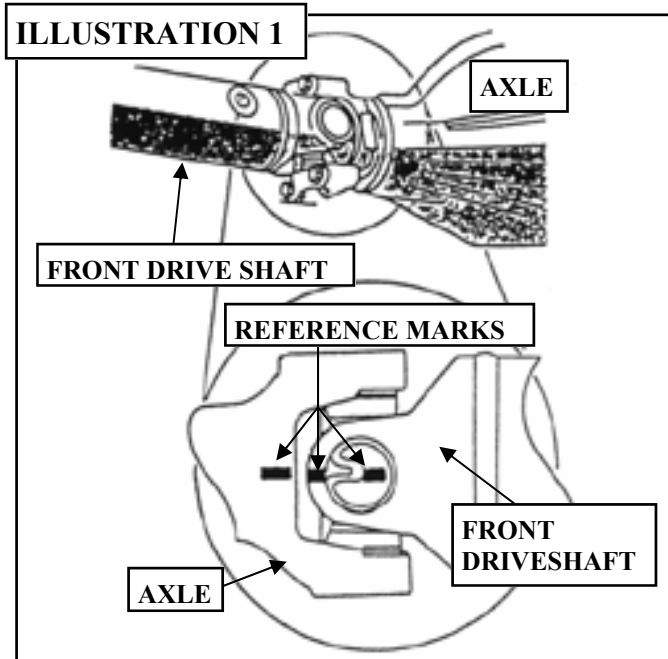

NOTE: If vehicle is equipped with ABS brakes remove sensor wire from the inboard side of the lower control arm.

- 3) Locate adjustment cam-bolts, positioned on front of existing lower control arms. Make an index mark as shown in ILLUSTRATION 2, for installation reference. Remove lower control arms.

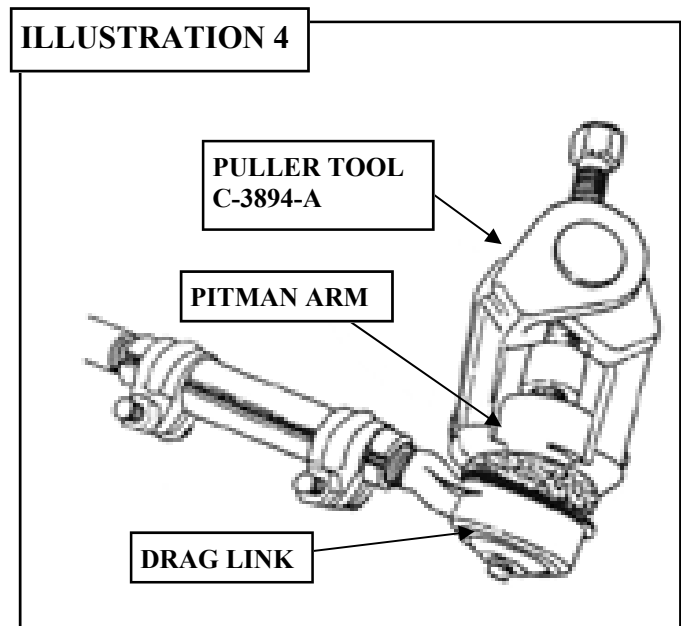
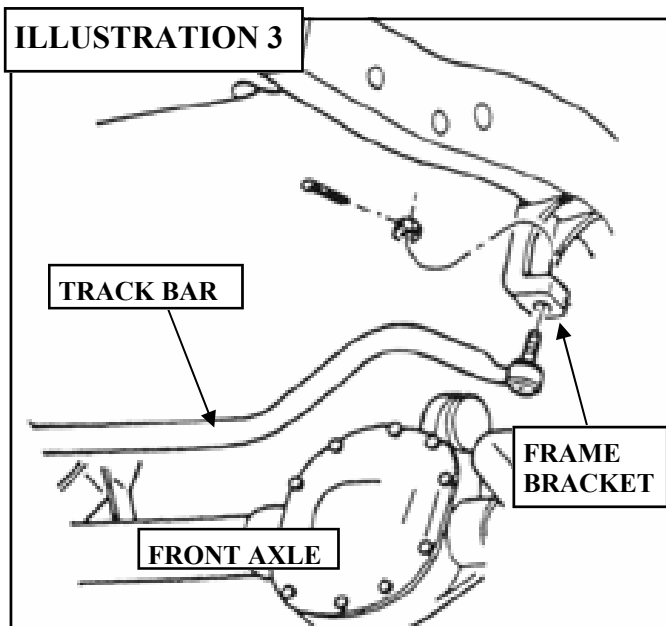

- 4) Remove front shock absorbers. Disconnect the stabilizer bar link at the axle.
- 5) Lower axle until coil spring is free from upper mount. Remove coil spring retainer bolt and remove the coil spring.

CAUTION: Use a universal Puller Tool to separate the track bar ball stud from the frame rail bracket. This will prevent damage to the ball stud seal.

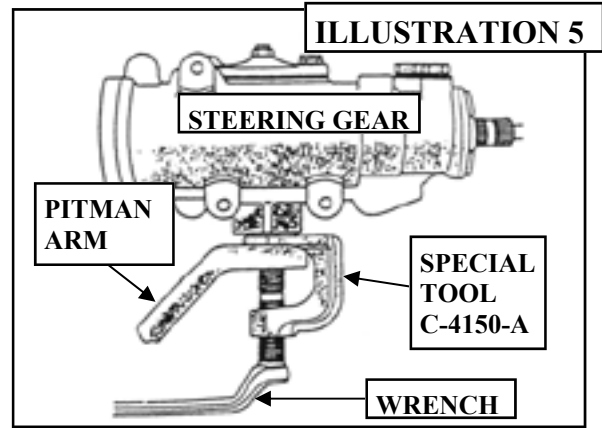

- 6) Disconnect the front track bar at the upper frame bracket as shown in ILLUSTRATION 3.
- 7) Remove the cotter pin and nut from the drag link at the pitman arm. Using the puller (C-3894-A), disconnect the pitman arm from the drag link as shown in ILLUSTRATION 4.

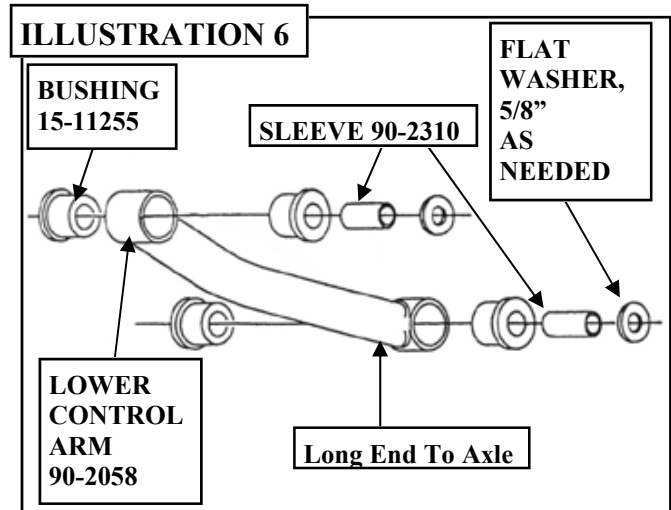

- 8) Remove the nut and washer from the steering gear shaft. Remove pitman arm using special pitman arm removal tool (C-4150A) as shown in ILLUSTRATION 5.

INSTALLATION - FRONT:

- 1) Insert the bushing (15-11255) and sleeve (90-2310), using a thin layer of lubricant, into the new lower control arms (90-2058) as shown in ILLUSTRATION 6.

- 2) Position the lower control arms in the front and rear brackets and install using the existing hardware as shown in ILLUSTRATION 7. Adjust the cam-bolt to the index mark. Torque lower cam-bolt nut to 85 ft./lbs. and upper frame bracket nut to 110 ft./lbs.

NOTE: If your vehicle is equipped with ABS brakes re-install sensor wire to inboard side of lower control arm.

- 3) Referring to ILLUSTRATION 8, assemble crosslink track bar brace

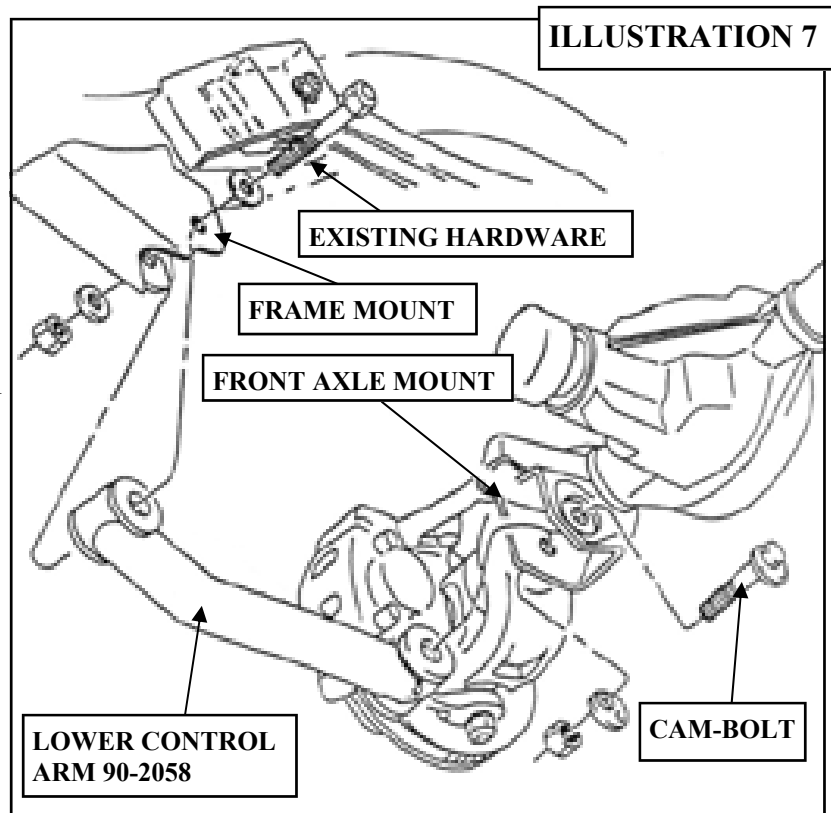

(90-2064) and secondary support brace (90-2065) using rod ends (JML8) and (JM8).

NOTE: Match groove at one end of the track bar brace to groove on rod end nut as shown in ILLUSTRATION 8. These ends have a left handed thread pattern. Attach rod end (JLM8) at this end only. Failure to do so will cause damage to threads on inside of track bar brace.

4) Drill out the hole in the existing track bar frame mount to 9/16" diameter. Install the block mount (90-1121) using the 9/16" hardware, as shown in ILLUSTRATION 9.

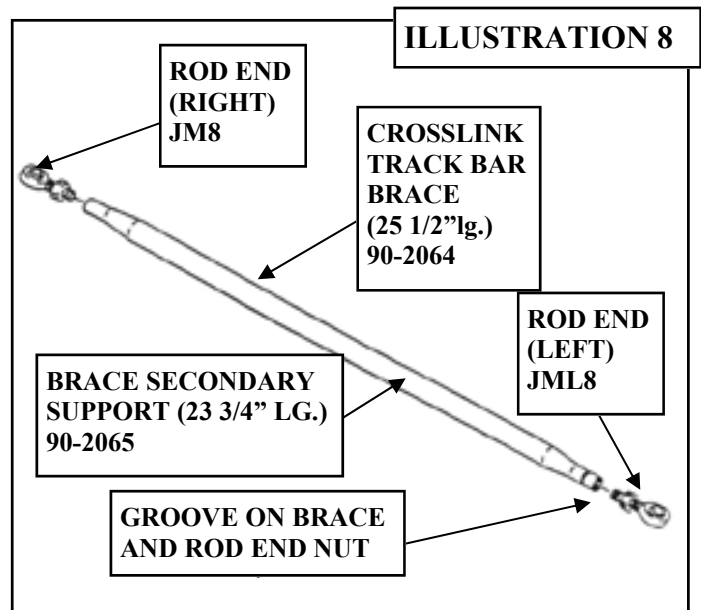

NOTE: Still referring to ILLUSTRATION 9, locate the oblong hole on passenger side of frame. Install the 25-1/2" long crosslink track bar brace (90-2064), 23-3/4" long brace secondary support, track bar mount tabs (90-1122), sleeve (90-2071), spacer (90-2014) with the supplied hardware in the order shown. Torque the 1/2" nut to 85 ft./lbs.

5) Attach the track bar mount bracket (90-1125) to the block mount (90-1121) using supplied hardware as shown in ILLUSTRATION 10. Install the opposite ends of the crosslink track bar brace (90-2064) to the track bar mount bracket (90-1125) and brace secondary support (90-2065) to block mount (90-1121). Re-connect the existing track bar into the new mounting position using existing hardware. Torque to 85 ft./lbs.

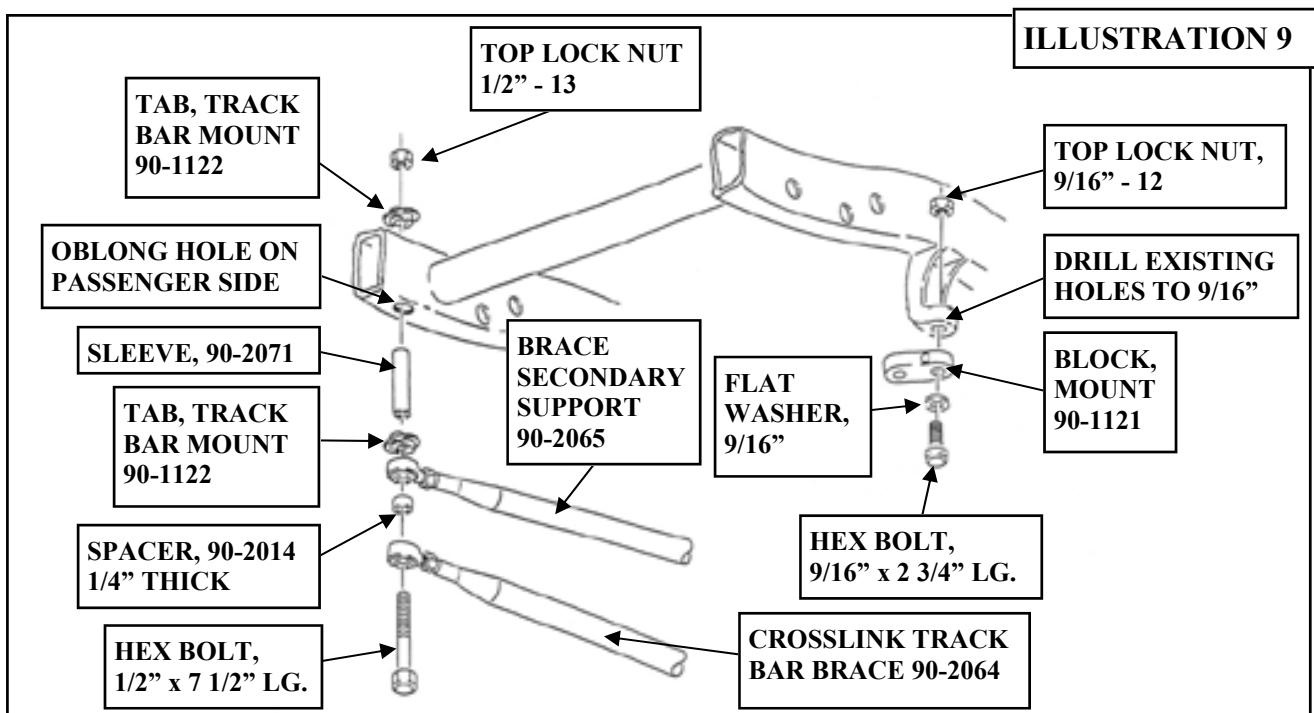

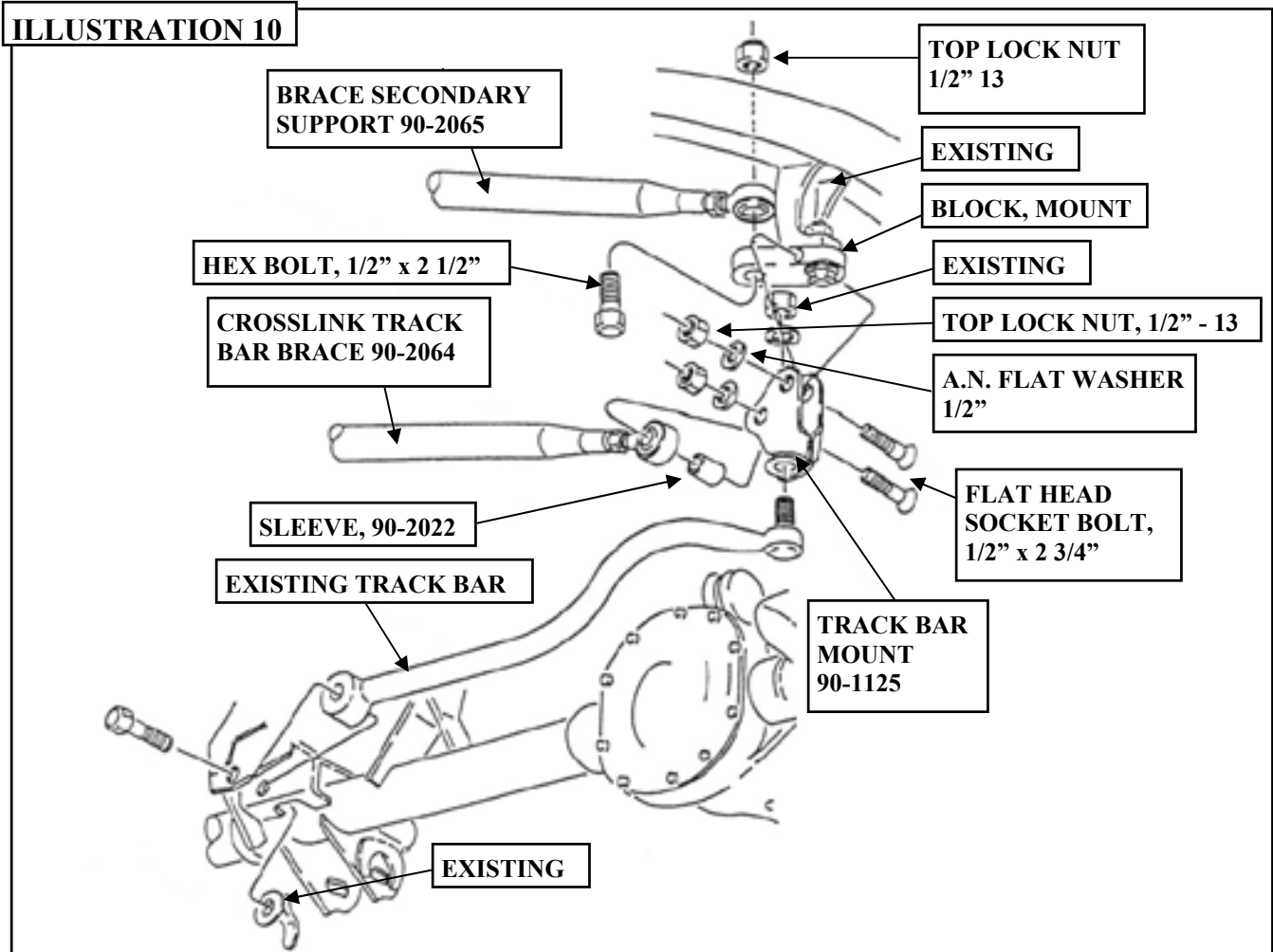

6) Using the existing hardware, install the new pitman arm (**YJ400**) onto the drag link (torque to 60 ft./lbs.) and steering gear shaft (torque to 185 ft./lbs). See ILLUSTRATION 11.

7) Install new bumpstop pad (**90-4002**) as shown in ILLUSTRATION 12. Mark center of lower coil spring pad. Using a **11/32"** diameter drill bit, drill a pilot hole in the previously marked area. Install using **3/8"** self-tapping hardware provided. torque to 25 ft./lbs.

NOTE: VERY IMPORTANT:

Compress front axle against the bumpstops. Check for clearance between differential and track bar mount and any related hardware. The block mount, track bar mount bolt allows the track bar mount to rotate to obtain clearance between track bar mount and differential. Be careful not to bind rod ends against the side of the track bar mount. Both brace and support bars should rotate slightly when installed, this will assure adequate clearance between rod ends and brackets. When clearance is obtained, torque 9/16" block mount to track bar mount bolt to 105 ft./lbs. Inadequate clearance between rod end and bracket will cause premature rod end failure.

⇒ See checks and adjustments on last page for critical information and instructions, concerning track bar mount bolts and hardware.

8) Position new front coil spring (55497) on axle pad. Re-install coil spring retainer and bolt. Torque to 16 ft./lbs. Raise the axle into position until coil spring seats in upper mount, then raise axle another 2". Install new longer shock absorbers (324515) as shown in ILLUSTRATION 13. Torque upper shock nuts to 17 ft./lbs. and lower nuts to 20 ft./lbs.

9) Install the hour glass bushings (45359) and sleeves (61150) and (60859H) as shown in ILLUSTRATION 14, into the sway bar link (90-2008).

10) Mount the sway bar front mount bracket (90-1010) to the sway bar using the 3/8" hardware provided. Attach sway bar link (90-2008) using provided hardware as shown in ILLUSTRATION 15. Torque nut to 30 ft./lbs.

11) Remove the (4) 6mm bolts that fasten the transfer case pivot bracket to the floor pan. This can be accessed by lifting the carpet on drivers side of the vehicle. Slide pivot bracket from pivot rod and set aside.

12) Support the transfer case skid plate. The transfer case and transmission are supported by the skid plate. Before removing the skid plate ensure that the transmission is properly supported. Remove the (6) bolts connecting the skid plate to the frame. Re-install transfer case skid plate with transfer case spacers (90-2003), conical spacers (90-2002) and supplied hardware as shown in ILLUSTRATION 16. Torque bolts to 55 ft./lbs.

13) Attach shifter drop brackets (90-1003) to transfer case pivot bracket using 6mm hardware provided. Install assembly into the existing mounting location using existing hardware (previously removed). See ILLUSTRATION 17A.

NOTE: It is very important that the shifter pivot rod protrudes through the self-aligning bearing on the pivot bracket approximately 3/8". By bending the opposite bracket on the transfer case, you can easily achieve this.

14) Re-connect the front drive shaft to the axle using the reference marks as guides. Refer back to ILLUSTRATION 1 if necessary.

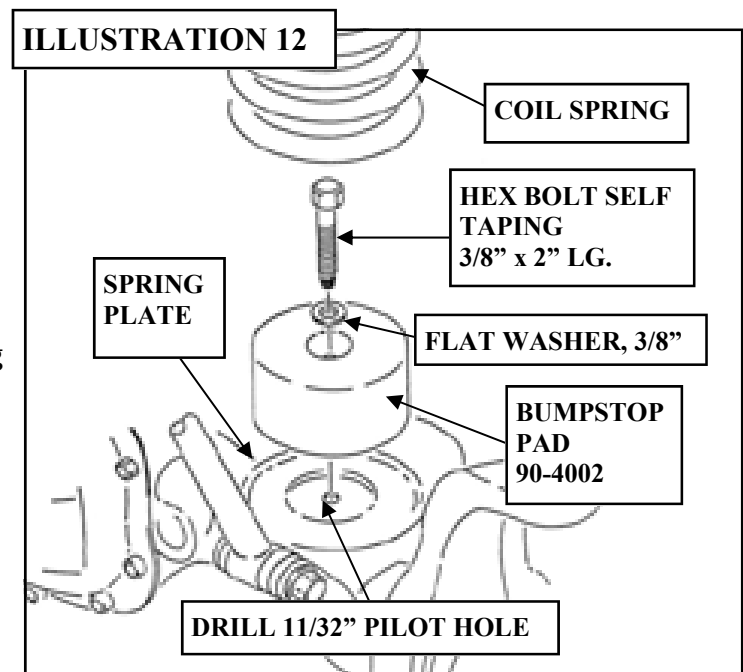
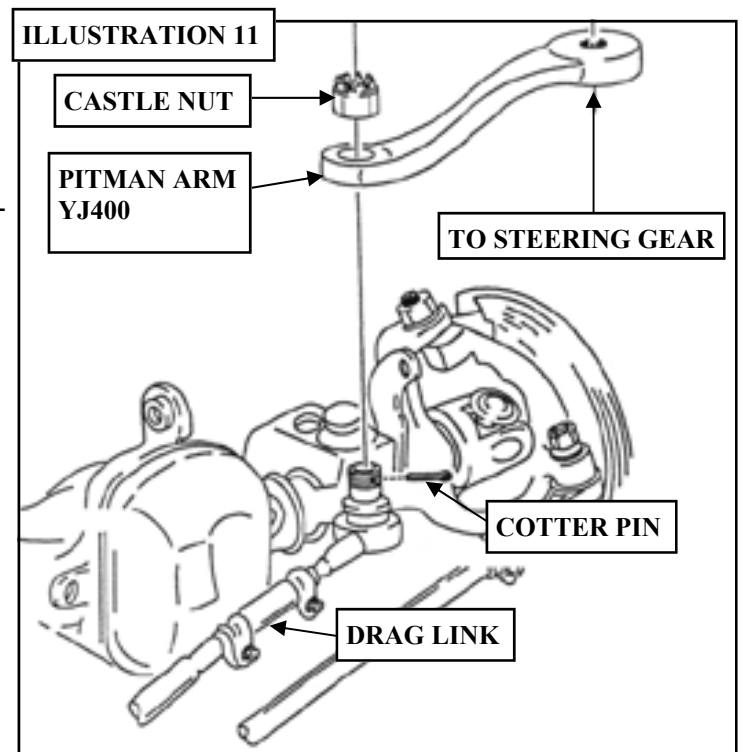

ILLUSTRATION 13

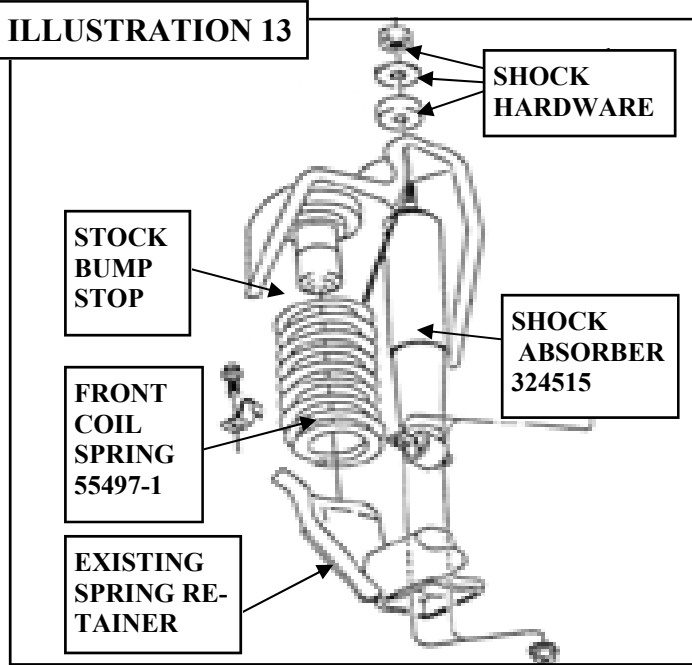

ILLUSTRATION 14

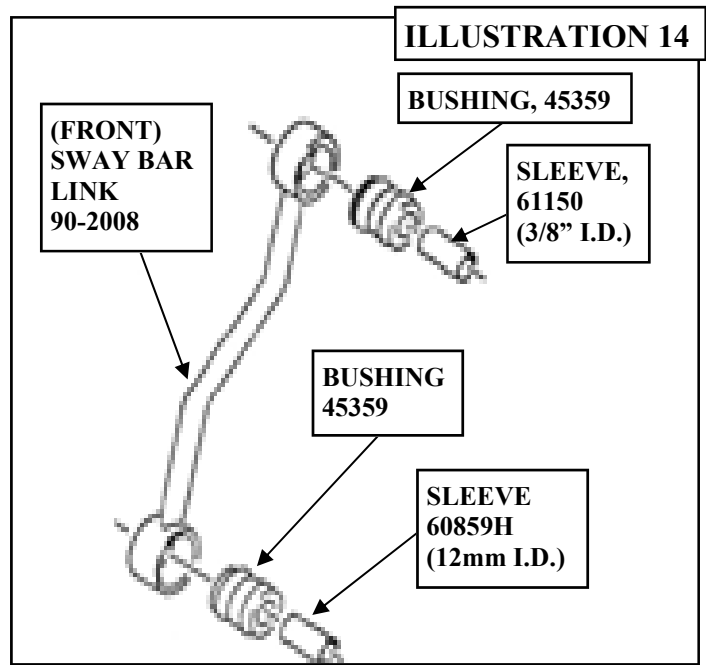
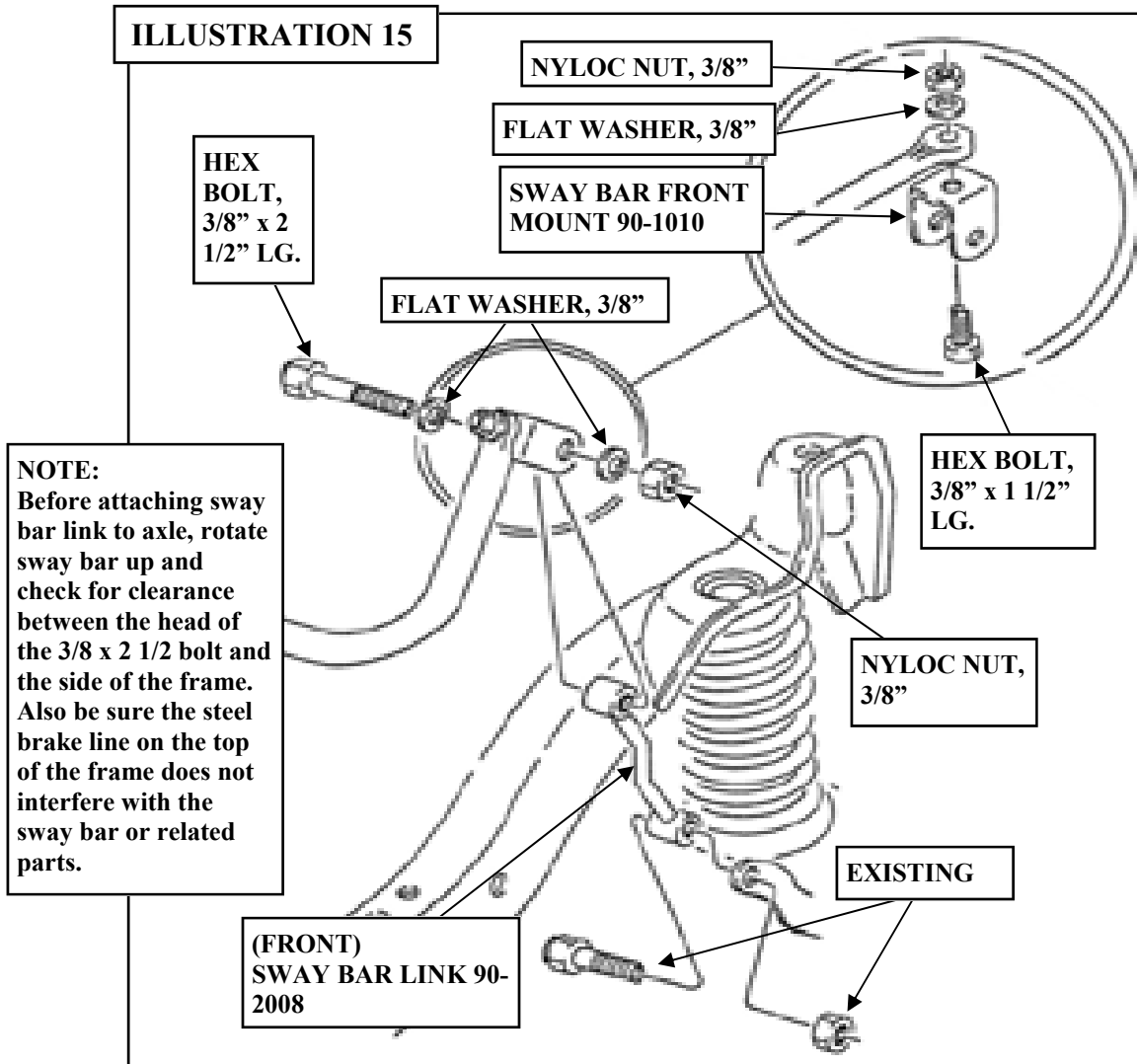

ILLUSTRATION 15



DISASSEMBLY - REAR:

- 1) Raise the rear of the vehicle, support frame with jack stands and remove rear wheels and tires.
- 2) Locate and remove existing rear lower control arms.
- 3) Disconnect lower track bar mount as shown in ILLUSTRATION 17B.
- 4) Locate and remove rear stabilizer bar and rear shock absorbers.
- 5) Lower rear axle until coil springs are free from upper seat. Remove coil springs.

INSTALLATION - REAR:

- 1) Position rear lower control arms (90-2058) into existing front and rear mounting brackets and install using hardware previously removed. Do not tighten at this time.
- 2) Install new rear bumpstop extensions (90-4003) using the supplied 10mm hardware as shown in ILLUSTRATION 18. Torque to 27 ft./lbs.
- 3) Install rear sway bar links (90-2009) as shown in ILLUSTRATION 19, using hour glass bush-

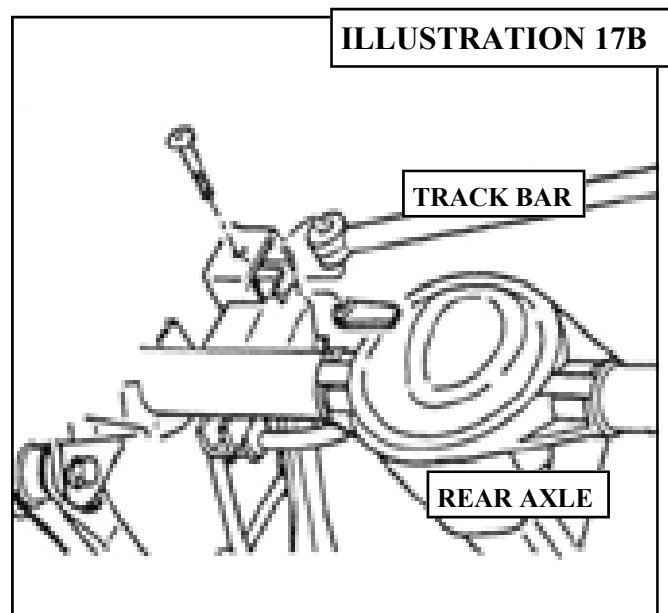
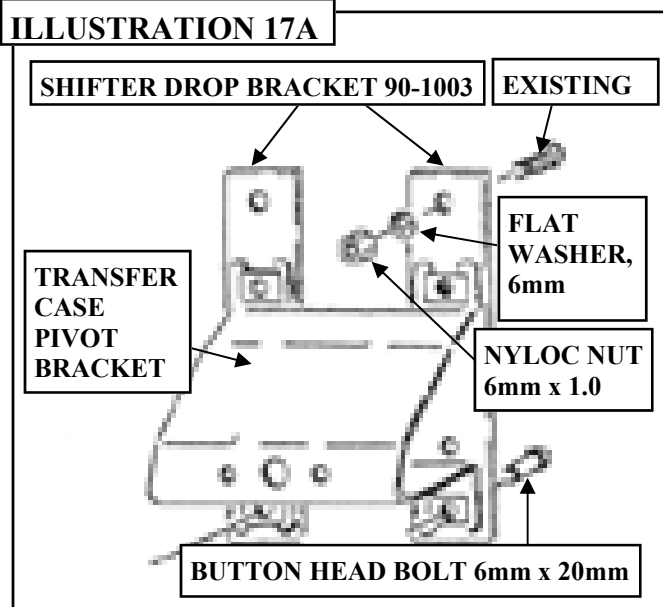
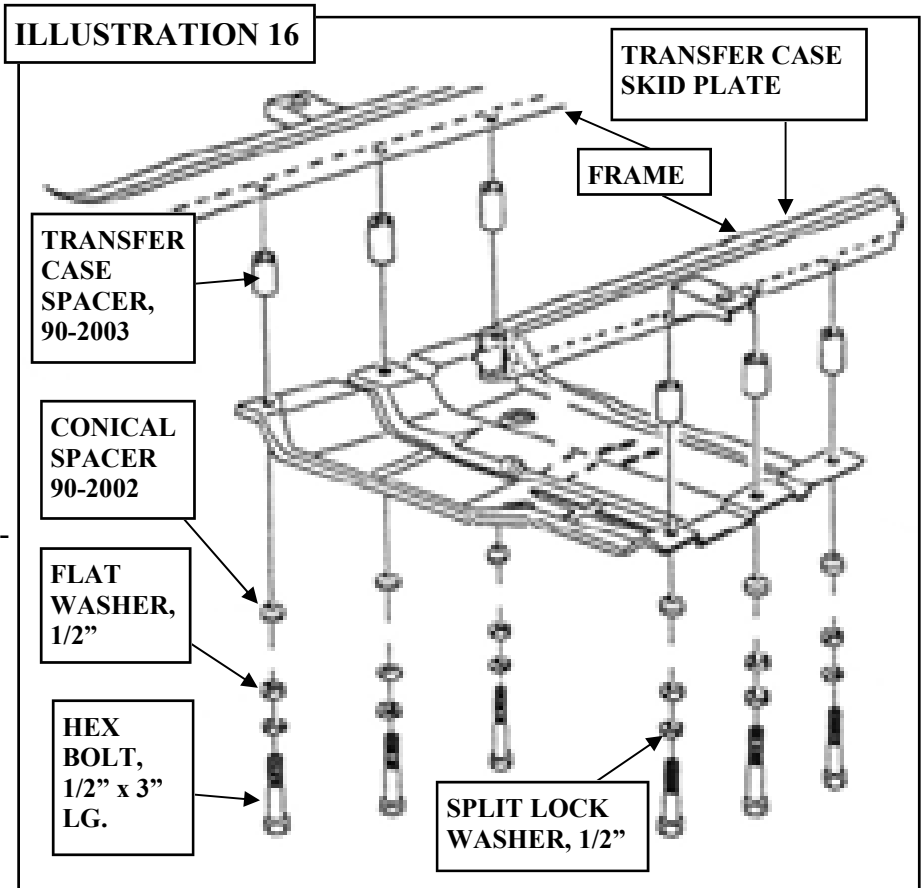

ings (600001). When re-installing existing stabilizer bar you must ensure that the bar is centered, equally spaced, over both sides of differential housing. Fasten using existing hardware. Torque to 40 ft./lbs.

4) Referring to ILLUSTRATION 20, install rear track bar mount bracket (90-1011) using 1.60" sleeve (90-2010) and supplied hardware. Torque 1/2" x 3" track bar bracket bolt to 65 ft./lbs. Drill out the 3/8" hole at the three 5/16" hole locations using bracket as template.

5) Install new rear coil springs (55498) and new longer shock absorbers (324509). At this time, torque existing lower control arm nuts to 130 ft./lbs.

6) Attach track bar into new track bar mounting bracket (90-1011), as shown in ILLUSTRATION 21, using existing OE Bolt. Torque nut to 60 ft./lbs.

7) Cycle steering lock to lock and inspect steering, suspension and driveline suspension and driveline systems for proper operation, tightness and adequate clearance. Recheck brake hose / fittings for leaks. Be sure all hoses are long enough.

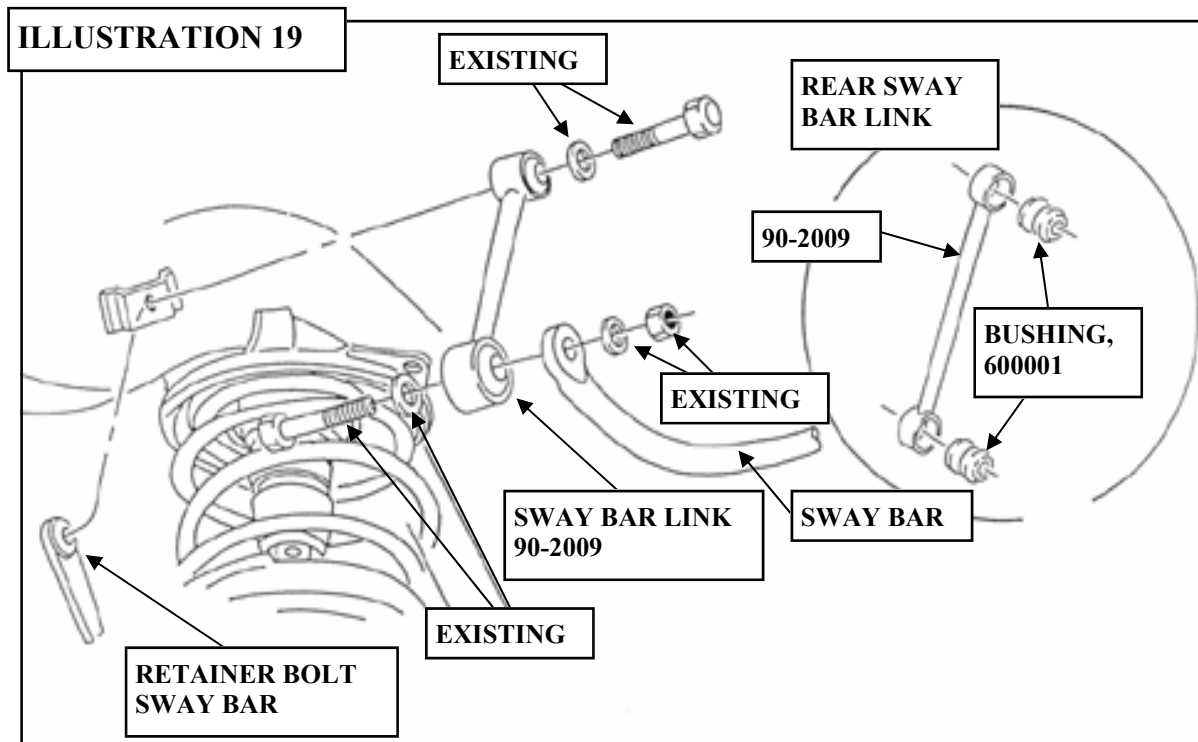
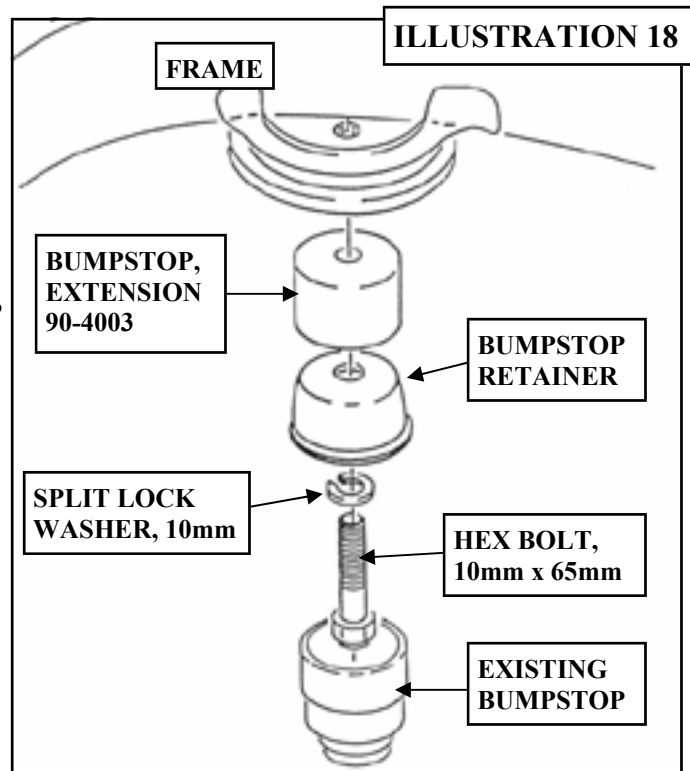
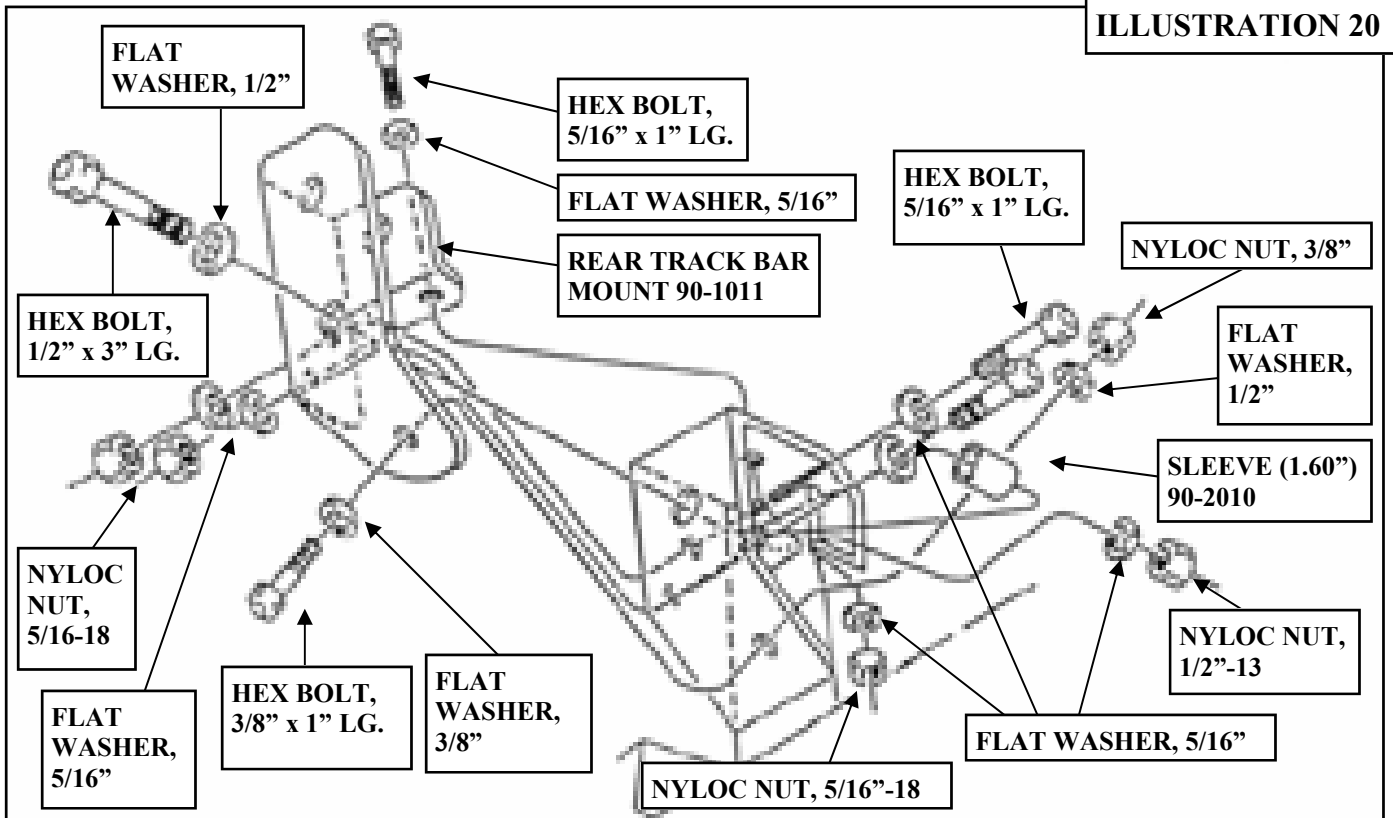

ILLUSTRATION 20



8) Install the wheels and tires. Remove the jack stands and lower the vehicle.

CHECKS AND ADJUSTMENTS: VERY IMPORTANT:

- ⇒ Recheck all hardware for tightness after the first 100 miles.
- ⇒ To adjust location of front axle (side to side), rotate crosslink track bar brace and the secondary support brace to move axle to desired location. Tighten jam nuts on rod ends, then torque 1/2" flat head countersunk allen bolts on track bar mount bracket to 90 ft./lbs.
- ⇒ Steering stops can be adjusted by use of spacers behind welded jam nuts, or be use of a secondary jam nut (not provided).
- ⇒ Headlights should be adjusted.
- ⇒ Rotate front and rear drive shafts with suspension hanging. Depending on engine,

ILLUSTRATION 21

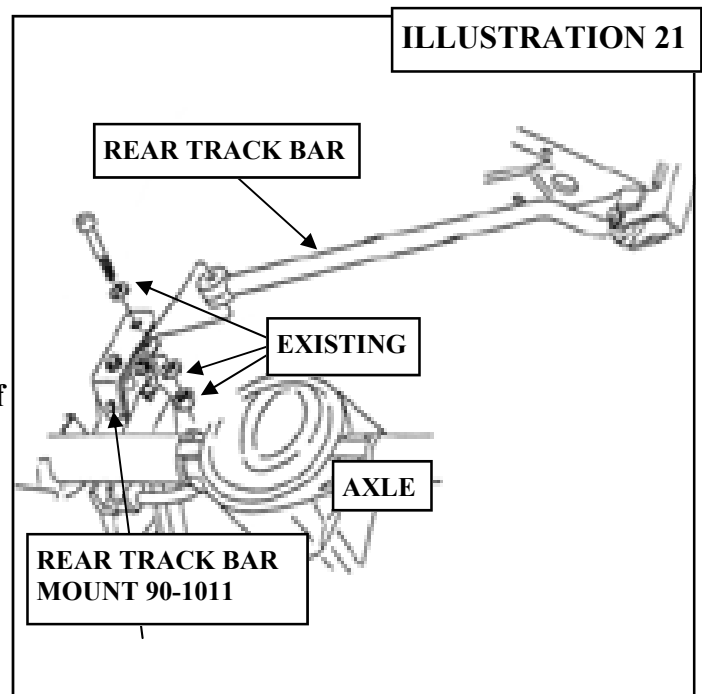

transmission and differential combinations, it may be necessary to increase the drop on the transfer case if u-joint-to-yoke interference is found. This can be accomplished with the use of 1/2" flat washers (not provided). 1/4" additional drop is usually sufficient.

⇒ **Alignment of front wheels will be required, use factory specifications.**

TORQUE SPECIFICATIONS:

**Lower Control Arms-to-Axle.....130 ft./lbs.
Front Shock Absorbers at Axle.....20 ft./lbs.**

Use this only as a guide for hardware without a called out torque specification in the instruction manual.

Bolt Torque and ID						
Decimal System			Metric System			
All Torques in Ft. Lbs. Maximums						
Bolt Size	Grade 5	Grade 8	Bolt Size	Class 9.8	Class 10.9	Class 12.9
5/16	15	20	M6	5	9	12
3/8	30	45	M8	18	23	27
7/16	45	60	M10	32	45	50
1/2	65	90	M12	55	75	90
9/16	95	130	M14	85	120	145
5/8	135	175	M16	130	165	210
3/4	185	280	M18	170	240	290

1/2-13x1.75 HHCS **Grade 5 Grade 8**
(No. of Marks + 2)

D T L X

G = Grade (Bolt Strength)
D = Nominal Diameter (Inches)
T = Thread Count (Threads per Inch)
L = Length (Inches)
X = Description (Hex Head Cap Screw)

M12-1.25x50 HHCS

D T L X

P = Property Class (Bolt Strength)
D = Nominal Diameter (Millimeters)
T = Thread Pitch (Thread Width, mm)
L = Length (Millimeters)
X = Description (Hex Head Cap Screw)

Notice to Owner operator, Dealer and Installer:

Vehicles that have been enhanced for off-road performance often have unique handling characteristics due to the higher center of gravity and larger tires. This vehicle may handle, react and stop differently than many passenger cars or unmodified vehicles, both on and off-road. You must drive your vehicle safely! Extreme care should always be taken to prevent vehicle rollover or loss of control, which can result in serious injury or even death. Always avoid sudden sharp turns or abrupt maneuvers and allow more time and distance for braking! Pro Comp reminds you to fasten your seat belts at all times and reduce speed! We will gladly answer any questions concerning the design, function, maintenance and correct use of our products.

Please make sure your Dealer/Installer explains and delivers all warning notices, warranty forms and instruction sheets included with Pro Comp product.

Application listings in this catalog have been carefully fit checked for each model and year denoted. However, Pro Comp reserves the right to update as necessary, without notice, and will not be held responsible for misprints, changes or variations made by vehicle manufacturers. Please call when in question regarding new model year, vehicles not listed by specific body or chassis styles or vehicles not originally distributed in the USA.

Please note that certain mechanical aspects of any suspension lift product may accelerate ordinary wear of original equipment components. Further, installation of certain Pro Comp products may void the vehicle’s factory warranty as it pertains to certain covered parts; it is the consumer’s responsibility to check with their local dealer for warranty coverage before installation of the lift.

Warranty and Return policy:

Pro Comp warrants its full line of products to be free from defects in workmanship and materials. Pro Comp’s obligation under this warranty is limited to repair or replacement, at Pro Comp’s option, of the defective product. Any and all costs of removal, installation, freight or incidental or consequential damages are expressly excluded from this warranty. Pro Comp is not responsible for damages and / or warranty of other vehicle parts related or non-related to the installation of Pro Comp product. A consumer who makes the decision to modify his vehicle with aftermarket components of any kind will assume all risk and responsibility for potential damages incurred as a result of their chosen modifications. Warranty coverage does not include consumer opinions regarding ride comfort, fitment and design. Warranty claims can be made directly with Pro Comp or at any factory authorized Pro Comp dealer.

IMPORTANT! To validate the warranty on this purchase please be sure to mail in the warranty card.

Claims not covered under warranty-

- Parts subject to normal wear, this includes bushings, bump stops, ball joints, tie rod ends and heim joints
 - Discontinued products at Pro Comp’s discretion
- Bent or dented product
- Finish after 90 days
- Leaf or coil springs used without proper bump stops
- Light bulbs
- Products with evident damage caused by abrasion or contact with other items
- Damage caused as a result of not following recommendations or requirements called out in the installation manuals
- Products used in applications other than listed in Pro Comp’s catalog
- Components or accessories used in conjunction with other manufacturer’s systems
- Tire & Wheel Warranty as per Pro Competition Tire Company policy
- Warranty claims without “Proof of Purchase”
- Pro Comp Pro Runner coil over shocks are considered a serviceable shock with a one-year warranty against leakage only. Rebuild service and replacement parts will be available and sold separately by Pro Comp. Contact Pro Comp for specific service charges.
- Pro Comp accepts no responsibility for any altered product, improper installation, lack of or improper maintenance, or improper use of our products.

E-Mail: tech@explorerprocomp.com
Website: www.explorerprocomp.com
Fax: (619) 216-1474
Ph: (619) 216-1444

PLACE
WARRANTY REGISTRATION
NUMBER
HERE: _____