

2360 Boswell Road
Chula Vista, CA 91914
Phone 619.216.1444
Fax 619.216.1474
E-Mail tech@explorerprocomp.com



PRO COMP SUSPENSION

Suspension Systems that Work!

MUST BE PURCHASED SEPERATELY:

Dodge 2500 cam bolts (Part#6505742AA) can be purchased from your local Dodge dealer.

**Part # 56703MX
2003-2004 Dodge,
2500, 4X4
3 Inch Lift kit**

This document contains very important information that includes warranty information and instructions for resolving problems you may encounter. Please keep it in the vehicle as a permanent record.

Part #	Description	Qty.	Illus.	Page
Box 1 of 2-PN #56703MX-1				
90-4008	3" Coil spacer	2	2	3
15-10992	Bump stop	2	3	5
90-6029	Hardware Pack: Brakes	1		
15-10966	3/8" Plastic hose clamp	4		
13-20447	#10 x 1/2" HWH zinc	4		
90-6069	Hardware Pack: Coil spacer	1		
70-0431751800	7/16" x 1 3/4" USS GR.8 Hex bolt	6	7	8
73-04300036	7/16" Split lock washer plated	6	7	8
90-2090	Lower control arm	2	4	6
90-2093	Upper control arm	2	4	6
90-6273	Bushing and sleeve pack lower arm	1		
15-10979	Lower arm bushing	8	4	6
90-2101	7/8" x 16mm x 2 5/8" Sleeve	4	4	6
90-6274	Bushing and sleeve pack upper arm	1		
15-11187	Upper arm bushing	8	4	6
90-2114	3/4" x 14mm x 2 3/8" Sleeve	4	4	6
90-2341	Sway bar drop	2	8	9
90-6267	Hardware Pack: Sway bar drop	1		
70-0371501800	3/8" x 1 1/2" USS GR. 8 Hex Bolt	4	8	9
72-037100816	3/8" Stover nut	4	8	9
73-03700034	3/8" SAE Flat washer	8	8	9
DC400-1	4" Pitman arm drop	1		8
90-3379	Track bar relocation bracket	1	8	9
90-6268	Hardware Pack: Track bar	1	8	9
70-0563001800	9/16" X 3" GR. 8 Hex bolt	1	8	9
72-056100816	9/16" USS Stover nut	1	8	9
73-05600034	9/16" SAE GR. 8 Flat washer	2	8	9
70-0504001800	1/2" X 4" GR. 8 Hex bolt	1	8	9
72-050100816	1/2" USS Stover nut	1	8	9
73-05000034	1/2" SAE GR. 8 Flat washer	2	8	9
70-0623001800	5/8" -18 X 3" GR. 8 Hex Bolt	1	8	9
72-062100816	5/8" Stover Nut	1	8	9
73-06200034	5/8" Flat Washer	2	8	9

Box 2 of 2 PN #56703MX-2

MX6104	MX Shocks (Front)	2	7	8
MX6105	MX Shocks (Rear)	2	A	10

Introduction:

- ◆ This installation requires a professional mechanic!
- ◆ We recommend that you have access to a Dodge service manual for your vehicle to assist in the disassembly and reassembly of your vehicle. It contains a wealth of detailed information.
- ◆ Prior to installation, carefully inspect the vehicle's steering and driveline systems paying close attention to the tie rod ends, wheel bearing preload, pitman and idler arm. Additionally, check steering-to-frame and suspension-to-frame attaching points for stress cracks. The overall vehicle must be in excellent working condition. Repair or replace all worn or damaged parts!
- ◆ Read the instructions carefully and study the illustrations before attempting installation! You may save yourself a lot of extra work.
- ◆ Check the parts and hardware against the parts list to assure that your kit is complete. Separating parts according to the areas where they will be used and placing the hardware with the brackets before you begin will save installation time.
- ◆ Check the special equipment list and ensure the availability of these tools.
- ◆ Secure and properly block vehicle prior to beginning installation.
- ◆ **ALWAYS** wear safety glasses when using power tools or working under the vehicle!
- ◆ Use caution when cutting is required under the vehicle. The factory undercoating is flammable. Take appropriate precautions. Have a fire extinguisher close at hand.
- ◆ Foot pound torque readings are listed on the Torque Specifications chart at the end of the instructions. These are to be used unless specifically directed otherwise. Apply thread lock compound where specified.
- ◆ **Please note that while every effort is made to ensure that the installation of your Pro Comp lift kit is a positive experience, variations in construction and assembly in the vehicle manufacturing process will virtually ensure that some parts may seem difficult to install. Additionally, the current trend in manufacturing of vehicles results in a frame that is highly flexible and may shift slightly on disassembly prior to installation. The use of pry bars and tapered punches for alignment is considered normal and usually does not indicate a faulty product. However, if you are uncertain about some aspect of the installation process, please feel free to call our tech support department at the number listed on the cover page. We do not recommend that you modify the Pro Comp parts in any way as this will void any warranty expressed or implied by the Pro Comp Suspension company.**
- ◆ Disconnect the negative battery cable when working on the vehicle.

Please Note:

- ⇒ Front end and head light realignment is necessary!
- ⇒ Speedometer and ABS recalibration will be necessary if larger tires (10% more than stock diameter) are installed.
- ⇒ Due to differences in manufacturing, dimensions and inflated measurements, tire and wheel combinations should be test fit prior to installation. Tire and wheel choice is crucial in assuring proper fit, performance, and the safety of your Pro Comp equipped vehicle. For this application, we recommend a wheel not to exceed 8" in width with a minimum backspacing of 4" must be used, additionally, a quality tire of radial design, not exceeding 35" tall X 12.5" wide is also recommended. Please note that the use of a 35" X 12.5" tire may require fender modification. Violation of these recommendations will not be endorsed as acceptable by Pro Comp Suspension and will void any and all warranties either written or implied.

1. Prior to installing this kit. With the vehicle on the ground, measure the height of your vehicle. This measurement can be recorded from the center of the wheel, straight up to the top of the inner fender lip. Record the measurements below.

LF: _____ RF: _____

LR: _____ RR: _____

2. Ensure that your work space is of adequate size and the work surface is level. Place the vehicle in neutral. Place your floor jack under the front axle and raise vehicle. Place jack stands under the frame rails behind the front wheel wells and lower the frame onto the stands. Remove the jack and place the vehicle back in gear, set the emergency brake, and place blocks both in front of and behind the rear wheels. Remove the wheels.
3. Remove any skid plates or debris shields from the bottom of the vehicle.
4. Unbolt both brake line brackets from the frame to allow for free movement of the suspension components.
5. Place an index mark on the bottom of the

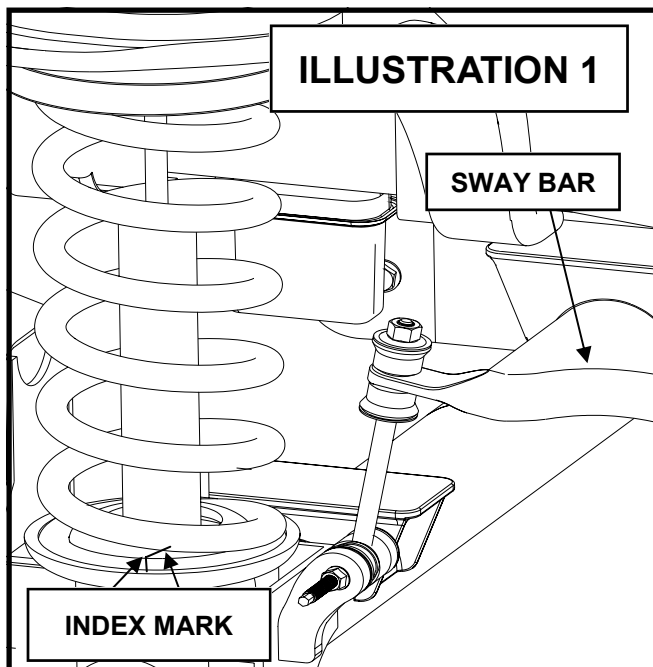

coil springs and lower spring pockets. This is so the coil spring and lower spring mount can later be installed in the correct position. See **ILLUSTRATION 1**.

6. Remove sway bar from end links then remove sway bar bushings, drop the sway bar out of the vehicle.

Work on one side of the vehicle at a time.

7. Raise the floor jack under the coil springs.
8. Locate the top shock mount in the engine compartment. Remove the nut, retainer and grommet from the shock. See **ILLUSTRATION 2**.
9. Remove the three nuts from the upper shock bracket, as shown in **ILLUSTRATION 2**. Remove the bracket and set aside.
10. Unbolt the shock absorber from the lower mount bracket on the axle. Remove the shock through the engine compartment.
11. Carefully lower the floor jack until coil springs are free from the upper spring pocket. Remove the coil springs.
12. Remove and set aside the upper rubber isolation pad on the coil and the stud ring from the spring pocket.
NOTE: You will not be reusing the stud ring in the installation.
13. Repeat on other side of the vehicle. ⚠
14. Locate the front rubber bump stops, mounted on the frame near the coils. Remove the bump stop from it's pocket using a pair of pliers. A back and forth action will assist in working it out.
15. Place the new bump stops, PN **15-10992**, in existing bump stop pockets, as shown in **ILLUSTRATION 3**. By using leverage against the bottom of the bump stops, force the bump stop into place (detergent soap may help if the fit is tight). ⚠

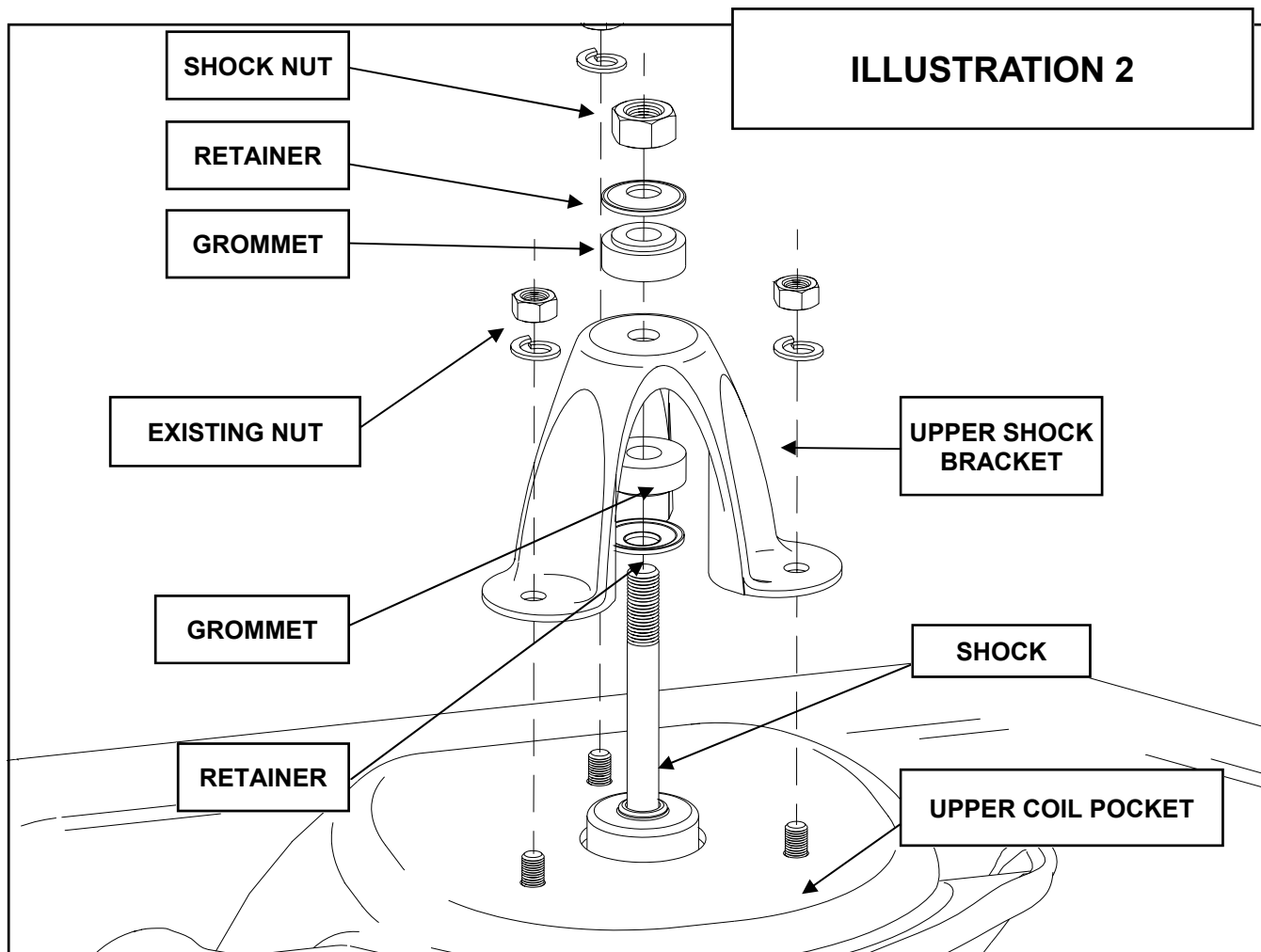

16. Use a jack to support the axle .

Complete control arm replacement on one side of the vehicle before removing the control arm from the other side.

17. On the bottom of the lower control arm. Mark the location of the index mark on the adjustment cam-bolt and bracket, remove the cam-bolt, washer and nut.

18. Next, remove the hardware from the frame bracket holding the lower control arm in place. Remove the control arm at this time.

19. Install the bushings and sleeves from hardware pack **90-6273** into the new

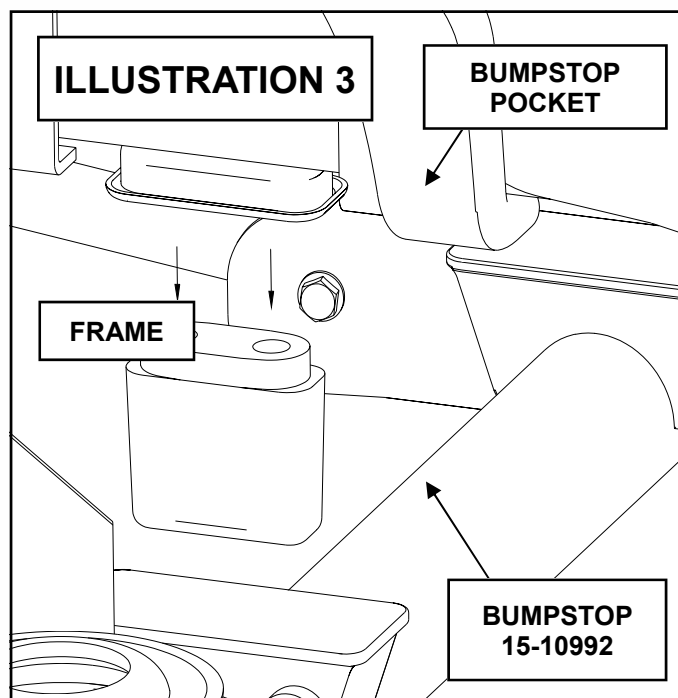

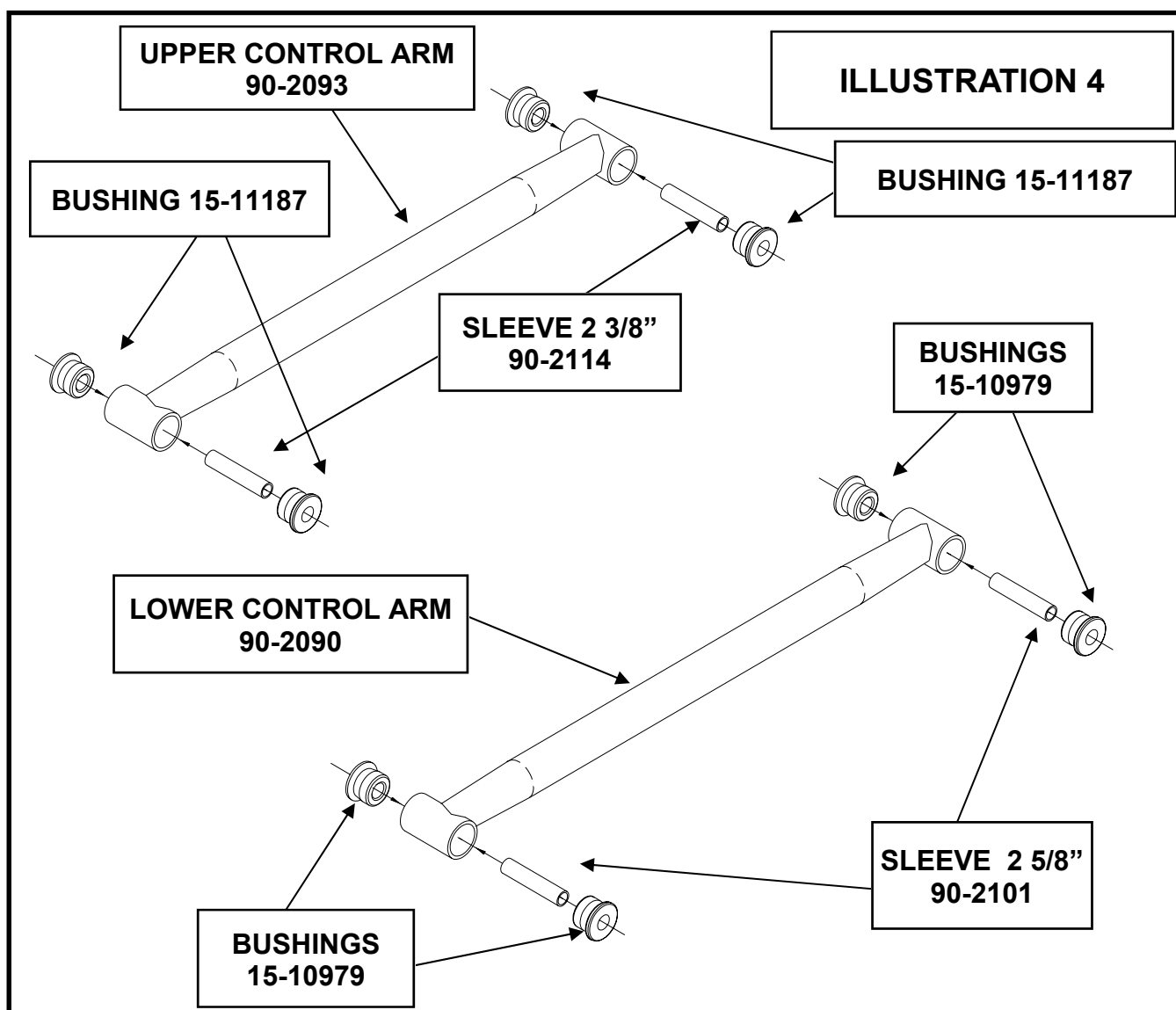

- lower control arm PN **90-2090** as shown in **ILLUSTRATION 4**. Install the supplied sleeves.
20. Install the new lower control arm with the OEM hardware. Install a new factory cam-bolt (**Dodge PN 505742AA**) and nut. **Do not reuse the original cam-bolt.** Do not torque fasteners at this time.
 21. Repeat on other side of the vehicle. ⚙
 22. Remove the upper control arm existing hardware from the axle bracket and frame bracket.
 23. Remove the existing upper control arm.
 24. Install the bushings and sleeves into the new upper control arms. Refer back to **ILLUSTRATION 4**. Install the supplied sleeve.
 25. Install the new upper control arm PN **90-2093** into the original mounting location.
NOTE: Rotating the lower adjusting cam-bolt may help installation.
 26. Use the existing hardware to fasten the upper control arm as shown in **ILLUSTRATION 5 and 6**. Do not torque at this time.
NOTE: On the V8 model the exhaust may need to be removed on the driver and passenger side. If so, remove ex-

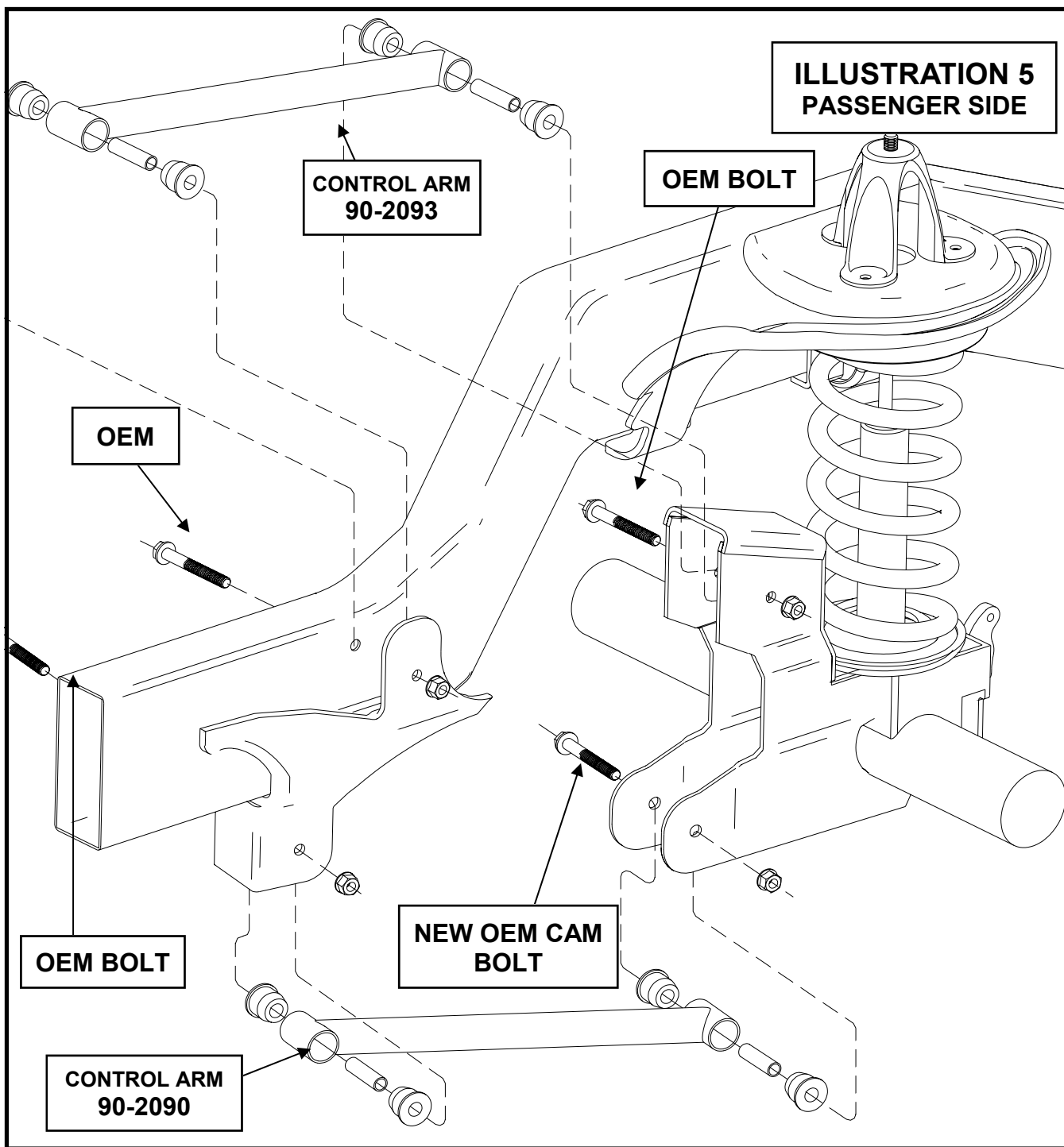

haust hanger bushings. Undo clamp on the turbo or unbolt from the header. Move exhaust out of the way to get the bolt to the control arm in and out. Remember to reinstall the exhaust to factory specifications.

27.Repeat these procedures on the other

side of the vehicle.

28.Tighten but do not torque the control arms at this time.

29.Place the spring spacer, PN **90-4008**, into the upper spring pocket on the frame, see **ILLUSTRATION 7**. Align the holes with each other. Then loosely bolt together

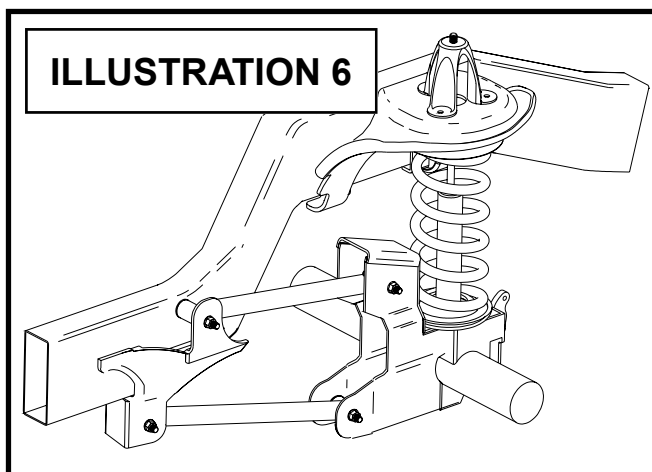

using $7/16''$ x $1-3/4''$ hex bolts and lock washers.

30. Insert the rubber isolator pad inside the recess of the spring spacer, see **ILLUSTRATION 7**.
31. Support the front axle with a jack. Disconnect track bar at the upper frame mount and inspect for excessive wear. The track bar, when attached, will not allow the front axle to drop down enough to install spring. Lower the axle and install the coil springs. Be sure the coils are properly indexed.
32. Drill out the existing track bar mounting hole in the frame to $5/8''$.
33. With hardware pack PN **90-6268** install track bar drop PN **90-3379** into the original track bar mount location. See **ILLUSTRATION 8**.
34. Secure the track bar drop bracket to the newly drilled hole using the supplied $5/8''$ X $3''$ bolt and hardware. Be sure to oil the threads of the bolt before installation.
35. The track bar drop bracket will be torqued later. Save the extra hardware to finish the installation.
36. Remove nut on pitman arm and remove the pitman arm from the steering box with the pitman arm puller. Install new pitman arm PN **DC400**. Make sure the new arm is installed in the same location and ori-

entation as the old pitman arm. Torque bolt to **200 ft-lbs**.

37. Rotate pitman tie rod $1/2$ turn and attach it to the bottom of the new pitman arm. Torque bolt to **45 ft-lbs**.
38. Raise the front axle with the floor jack so that it compresses the front coil springs and attach track bar with the $3''$ x $9/16''$ bolt washers and nut. See **ILLUSTRATION 8**.
39. Install your new Pro Comp shocks (PN

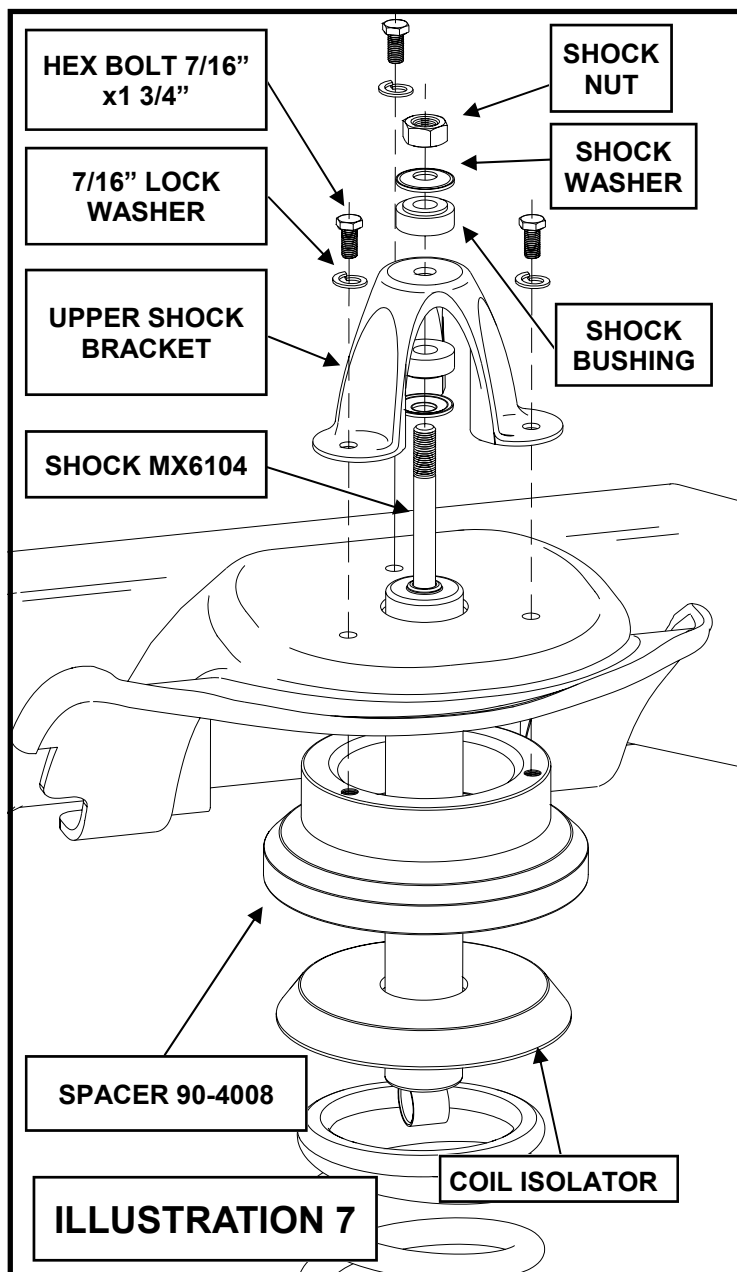

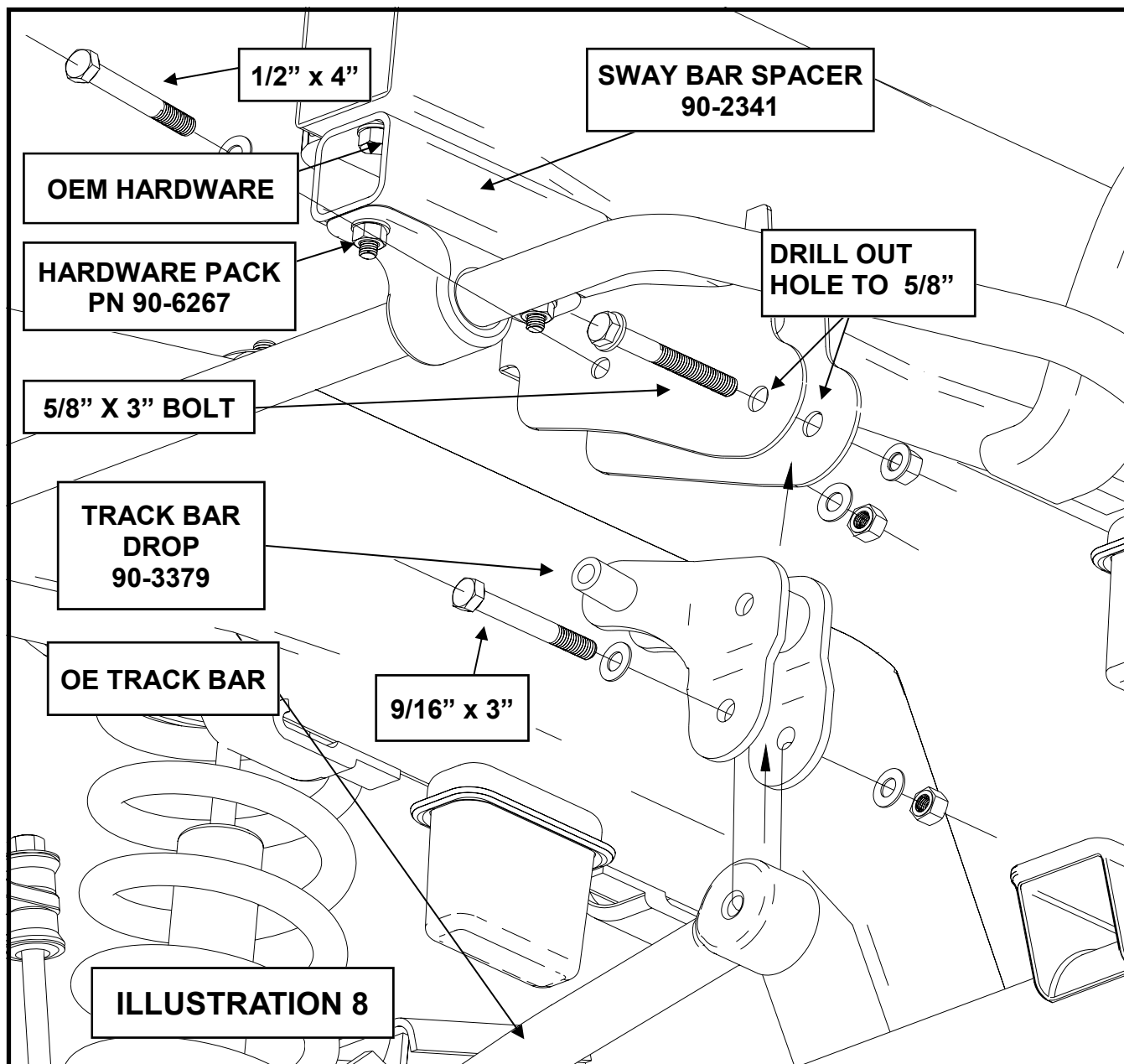

MX6104) through the coil spring from the engine compartment. Install the lower shock bolt and torque this hardware to **60 ft-lbs.**

40. Remove the **7/16"** hex bolts from the spring spacer. Align holes and install upper shock tower. See **ILLUSTRATION 7.** Install **7/16" x 1-3/4"** bolts, nuts and washers and torque to **35 ft-lbs.**

41. Install the upper shock mount using the grommet and retainer, fastening the

shock stud and to the shock bracket with the upper shock nut.

42. Repeat on the other side of the vehicle. ⚙

43. Bolt sway bar spacer PN **90-2341** the frame using OEM bolts. Attach sway bar and bushings to sway bar spacer using hardware pack, PN **90-6267.** See **Illustration 8.** ⚙

44. Install the hose clamps and screws from hardware pack PN **90-6029.** To the

brake lines.⊕

45. Install your wheels and tires and lower the vehicle to the ground. Tighten the lug nuts to **90 ft-lbs**. ⊕
46. Torque the control arms to specifications chart in the rear of the instructions.
47. With a jack and some jack stands you will need to center the front axle under the truck. You can use a point on each side of the frame and the axle to use as a reference.
48. Once the axle is centered under the truck place the template of the track bar relocation bracket, located on page 12, over the bolts on the rear of the frame and drill a pilot hole in the frame for the third hole into the frame and the track bar relocation bracket 90-3038. Refer to **ILLUSTRATION 8**.
49. With the vehicle to the ground. Drill the new hole in the frame and through the bracket to 1/2 inch. Use the 1/2 X 4 inch bolt, washers and nut to fasten the bracket.

50. Torque the track bar drop hardware according to the torque chart on page 11. Torque the 5/8" X 3" bolt to 150 ft./lbs.
51. Reattach sway bar end links with the vehicle on the ground. Torque down end links and sway-bar bolts.
52. On both sides of the vehicle, check the routing of the brake lines and the ABS wire harnesses. There must be no pinching, rubbing, or stretching of any component. Use zip ties to secure these items to the steering components. At full droop, cycle the steering from lock to lock while observing the reaction of these components. Reposition them if needed.
53. Recheck for proper installation and torque, of all of the newly installed hardware.
54. Have your vehicle aligned.
55. After 100 miles recheck for proper torque on all newly installed hardware.
56. Have your headlights adjusted.
57. Recheck all hardware for tightness after off road use. ⊕

Rear Installation

1. Block the front tires and raise the rear of the vehicle. Support the frame with jack stands forward of the rear springs.
2. Remove the wheels and tires.
3. Remove the shocks on both sides of the vehicle. It may be necessary that you slightly raise the axle to unload the shocks for removal.
4. Install your new Pro Comp shocks (PN **MX6105**) and torque this hardware to **60 ft./lbs**.
5. Reinstall the wheels and tires and lower the vehicle to the ground.
6. Recheck the wheel lug torque on all four

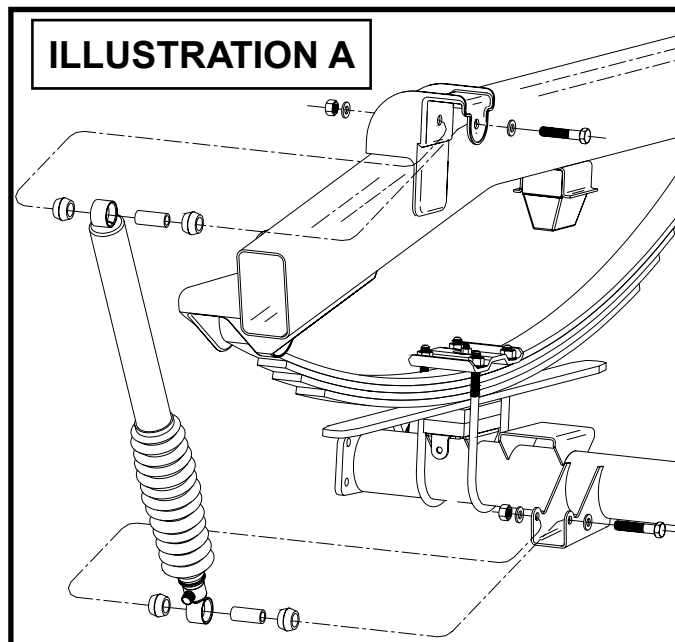

wheels at this time.

7. Recheck all hardware for proper installation and torque at this time. 🔄

Optional Equipment Available from your Pro Comp Distributor!

Check out our outstanding selection of Pro Comp tires to compliment your new installation!

Bolt Torque and ID						
Decimal System			Metric System			
All Torques in Ft. Lbs.						
Bolt Size	Grade 5	Grade 8	Bolt Size	Class 9.8	Class 10.9	Class 12.9
5/16	15	20	M6	5	9	12
3/8	30	45	M8	18	23	27
7/16	45	60	M10	32	45	50
1/2	65	90	M12	55	75	90
9/16	95	130	M14	85	120	145
5/8	135	175	M16	130	165	210
3/4	185	280	M18	170	240	290

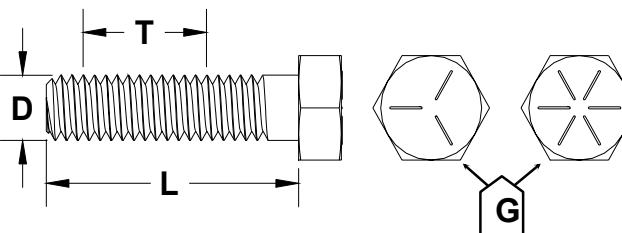
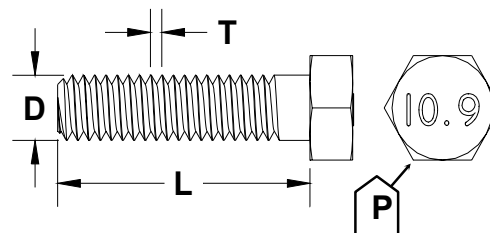
 <p>1/2-13x1.75 HHCS</p> <p>Grade 5 Grade 8 (No. of Marks + 2)</p> <p>D T L X</p>	 <p>M12-1.25x50 HHCS</p> <p>D T L X</p>
<p>G = Grade (Bolt Strength)</p> <p>D = Nominal Diameter (Inches)</p> <p>T = Thread Count (Threads per Inch)</p> <p>L = Length (Inches)</p> <p>X = Description (Hex Head Cap Screw)</p>	<p>P = Property Class (Bolt Strength)</p> <p>D = Nominal Diameter (Millimeters)</p> <p>T = Thread Pitch (Thread Width, mm)</p> <p>L = Length (Millimeters)</p> <p>X = Description (Hex Head Cap Screw)</p>

Track bar relocation bracket template. Cut out bolt holes and cut around outside. Place over bolts and frame then follow the instructions to drill out third hole. The center to center dimension of the two top holes is 4.4609". If the image is distorted it can be shrunk or enlarged on a copy machine.

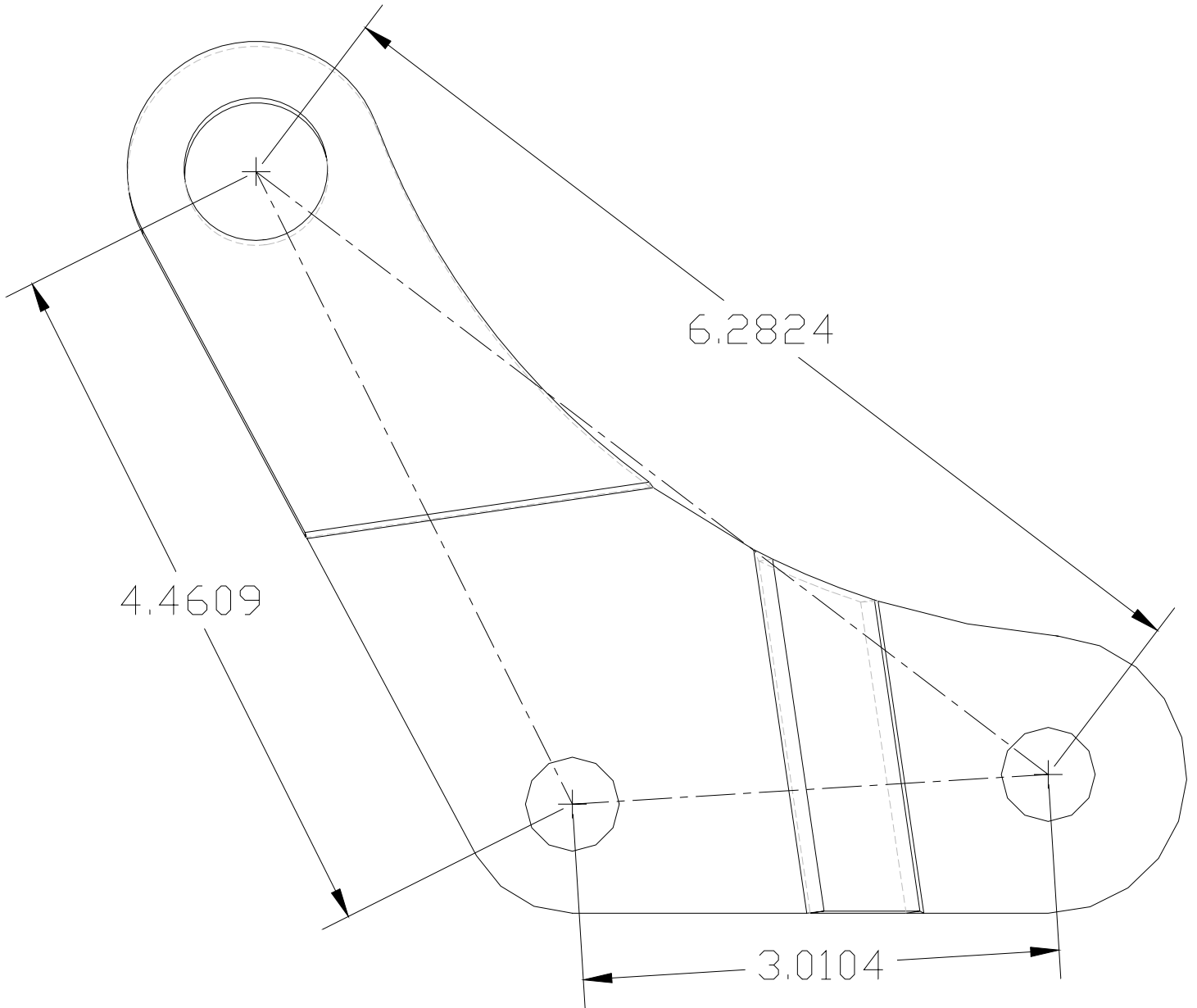

Notice to Owner operator, Dealer and Installer:

Vehicles that have been enhanced for off-road performance often have unique handling characteristics due to the higher center of gravity and larger tires. This vehicle may handle, react and stop differently than many passenger cars or unmodified vehicles, both on and off-road. You must drive your vehicle safely! Extreme care should always be taken to prevent vehicle rollover or loss of control, which can result in serious injury or even death. Always avoid sudden sharp turns or abrupt maneuvers and allow more time and distance for braking! Pro Comp reminds you to fasten your seat belts at all times and reduce speed! We will gladly answer any questions concerning the design, function, maintenance and correct use of our products.

Please make sure your Dealer/Installer explains and delivers all warning notices, warranty forms and instruction sheets included with Pro Comp product.

Application listings in this catalog have been carefully fit checked for each model and year denoted. However, Pro Comp reserves the right to update as necessary, without notice, and will not be held responsible for misprints, changes or variations made by vehicle manufacturers. Please call when in question regarding new model year, vehicles not listed by specific body or chassis styles or vehicles not originally distributed in the USA.

Please note that certain mechanical aspects of any suspension lift product may accelerate ordinary wear of original equipment components. Further, installation of certain Pro Comp products may void the vehicle’s factory warranty as it pertains to certain covered parts; it is the consumer’s responsibility to check with their local dealer for warranty coverage before installation of the lift.

Warranty and Return policy:

Pro Comp warrants its full line of products to be free from defects in workmanship and materials. Pro Comp’s obligation under this warranty is limited to repair or replacement, at Pro Comp’s option, of the defective product. Any and all costs of removal, installation, freight or incidental or consequential damages are expressly excluded from this warranty. Pro Comp is not responsible for damages and / or warranty of other vehicle parts related or non-related to the installation of Pro Comp product. A consumer who makes the decision to modify his vehicle with aftermarket components of any kind will assume all risk and responsibility for potential damages incurred as a result of their chosen modifications. Warranty coverage does not include consumer opinions regarding ride comfort, fitment and design. Warranty claims can be made directly with Pro Comp or at any factory authorized Pro Comp dealer.

IMPORTANT! To validate the warranty on this purchase please be sure to mail in the warranty card.

Claims not covered under warranty-

- Parts subject to normal wear, this includes bushings, bump stops, ball joints, tie rod ends and heim joints
 - Discontinued products at Pro Comp’s discretion
- Bent or dented product
- Finish after 90 days
- Leaf or coil springs used without proper bump stops
- Light bulbs
- Products with evident damage caused by abrasion or contact with other items
- Damage caused as a result of not following recommendations or requirements called out in the installation manuals
- Products used in applications other than listed in Pro Comp’s catalog
- Components or accessories used in conjunction with other manufacturer’s systems
- Tire & Wheel Warranty as per Pro Competition Tire Company policy
- Warranty claims without “Proof of Purchase”
- Pro Comp Pro Runner coil over shocks are considered a serviceable shock with a one-year warranty against leakage only. Rebuild service and replacement parts will be available and sold separately by Pro Comp. Contact Pro Comp for specific service charges.
- Pro Comp accepts no responsibility for any altered product, improper installation, lack of or improper maintenance, or improper use of our products.

**E-Mail: tech@explorerprocomp.com
Website: www.explorerprocomp.com
Fax: (619) 216-1474
Ph: (619) 216-1444**

<u>PLACE</u>
<u>WARRANTY REGISTRATION</u>
<u>NUMBER</u>
<u>HERE:</u> _____