

2360 Boswell Road
Chula Vista, CA 91914
Phone 619.216.1444
Fax 619.216.1474
E-Mail tech@explorerprocomp.com



PRO COMP SUSPENSION

Suspension Systems that Work!

IMPORTANT: In its current configuration the 59005B/59005BMX will not fit vehicles equipped with the "Auto-Leveling Rear Suspension".

This kit can be installed to the vehicle if the "Auto-Leveling Rear Suspension" air shocks and compressor are removed from the vehicle and two NISSAN PN# 55020-7s001 rear coils are purchased and installed.

Please contact our technical line at 1.800.776.0767 for availability of an "Auto-Leveling Rear Suspension" kit.

***NOTE: IF INSTALLING THIS KIT ON A 2WD VEHICLE
SEE PAGE 24 FOR ADDITIONAL 2WD INSTRUCTIONS***

**Part #59005/59005MX
2004-2006 NISSAN
ARMADA
2WD/4WD
w/o auto ride**

This document contains very important information that includes warranty information and instructions for resolving problems you may encounter. Please keep it in the vehicle as a permanent record.

BOX 1 of 4-PN 59005/59005MX-1

| Part # | Description | Qty. | Illus. | Page |
|-----------------|---|-------------|---------------|-------------|
| 90-3132 | REAR CROSSMEMBER | 1 | 4,5 | 11 |
| 90-3119 | SWAY BAR ADAPTER- Driver | 1 | 9 | 15 |
| 90-3122 | SWAY BAR ADAPTER- Passenger | 1 | - | - |
| 90-6317 | HARDWARE PACK: Spacer Mount | 1 | - | - |
| 72-043200810 | 7/16"-20 GR. 8 PLATED HEX NUT | 6 | 7a,7b | 13 |
| 73-04300830 | 7/16" SAE FLATWASHER ZINC | 6 | 7a,7b | 13 |
| 73-04300836 | 7/16" SPLIT LOCK WASHER | 6 | 7a,7b | 13 |
| 90-6184 | HARDWARE PACK: Comp Strut | 1 | - | - |
| 70-0504001800 | 1/2"-13 X 4" HEX BOLT GR.8 YELLOW ZINC | 4 | 10 | 16 |
| 73-05000030 | 1/2" SAE FLAT WASHERS ZINC | 8 | 10 | 16 |
| 72-05000100512 | 1/2"-13 NYLON INSERT LOCK NUT ZINC | 4 | 10 | 16 |
| 90-2126 | COMPRESSION STRUTS | 2 | 10 | 16 |
| 90-6263 | HARDWARE PACK: Bushings And Sleeves | 1 | - | - |
| 15-11148 | COMPRESSION STRUT BUSHING | 8 | 10 | 16 |
| 90-2109 | SLEEVE; COMPRESSION STRUT - 2.75" | 4 | 10 | 16 |
| 90-1104 | COMPRESSION STRUT MOUNT | 2 | 10 | 16 |
| 90-6424 | HARDWARE PACK: Comp Strut/Brake Line/ Skid Plate | 1 | - | - |
| 90-1216 | LOAD WASHER- 1.50" O.D. | 4 | 11 | 17 |
| 90-1838 | COMPRESSION STRUT SPACER | 2 | 10 | 16 |
| 90-2481 | SWAY BAR END LINKS | 2 | 9 | 15 |
| 90-6359 | HARDWARE PACK: Crossmember/ Comp Strut/Shock | 1 | - | - |
| 70-0564501800 | 9/16" X 4 1/2" GR. 8 HEX BOLT | 4 | 2,4 | 9,11 |
| 72-056100816 | 9/16" STOVER NUT | 4 | 2,4 | 10,11 |
| 73-05600834 | 9/16" HARDENED SAE FLAT WASHER | 8 | 2,4 | 10,11 |
| 73-07500832 | 3/4" USS FLAT WASHER | 2 | 10 | 16 |
| 71-141001501000 | 14MM X 1.5 X 100MM 10.9 HEX BOLT | 1 | 5 | 11 |
| 73-01410930 | 14MM 10.9 FLAT WASHER | 1 | 5 | 11 |
| 90-3125 | FRONT CROSSMEMBER | 1 | 2,3 | 10,11 |
| 90-6040 | HARDWARE PACK: Comp Strut | 1 | - | - |
| 70-0501501800 | 1/2" X 1 1/2" USS GR. 8 HEX BOLT | 2 | 10 | 16 |
| 72-05000100815 | 1/2" USS GR. 8 USS STOVER NUT | 2 | 10 | 16 |
| 73-05000042 | 1/2" USS HARDENED FLAT WASHER | 4 | 10 | 16 |
| 90-6425 | HARDWARE PACK: Rear Brake line Drop/Skid Plate | 1 | - | - |
| 70-0370751800 | 3/8"-16 X 3/4" GR. 8 BOLTS | 2 | 11 | 17 |
| 73-03700830 | 3/8" USS FLAT WASHER | 2 | 11 | 17 |
| 90-6364 | HARDWARE PACK: Crossmember | 1 | - | - |
| 90-3117 | REAR CROSSMEMBER SPACER | 2 | 5 | 11 |
| 90-3137 | BLOCK OFF PLATE | 8 | 2,4,5 | 10,11 |
| 90-6360 | HARDWARE PACK: Sway Bar | 1 | - | - |
| 71-120701501000 | 12MM X 1.5 X 70 GR. 10.9 HEX BOLT | 2 | 9 | 15 |

| Part # | Description | Qty. | Illus. | Page |
|--------------------------------------|---|----------|--------------------|-----------------|
| 73-01210930 | 12MM SAE 10.9 FLAT WASHER | 2 | 9 | 15 |
| 72-12175816 | 12MM X 1.5 10.9 STOVER NUT | 2 | 9 | 15 |
| 73-04300832 | 7/16" USS GR. 8 FLAT WASHER | 2 | 9 | 14 |
| 70-0431251800 | 7/16" X 1 1/4" GR. 8 HEX BOLT | 2 | 9 | 15 |
| 72-043100816 | 7/16"-14 STOVER | 2 | 9 | 15 |
| 73-04300834 | 7/16" HARDENED SAE FLAT WASHER | 4 | 9 | 15 |
| 70-0372501800 | 3/8"-16 X 2 1/2" GR. 8 BOLTS | 2 | 9 | 15 |
| 72-037100816 | 3/8" STOVER NUT | 2 | 9 | 15 |
| 73-03700834 | 3/8" HARDENED SAE FLAT WASHER | 4 | 9 | 15 |
| 70-0311251800 | 5/16" X 1 1/4" GR. 8 HEX BOLT | 2 | 9 | 15 |
| 72-031100816 | 5/16" STOVER NUT | 2 | 9 | 15 |
| 73-03100834 | 5/16" HARDENED SAE FLAT WASHER | 4 | 9 | 15 |
| 90-6426 | HARDWARE PACK: Steering stop Reinforcement Plate | 1 | - | - |
| 97-3284 | STEERING STOP REINFORCEMENT PLATE | 2 | 9 | 15 |
| BOX 2 of 4-PN 59005/59005MX-2 | | | | |
| 90-4114 | STEERING KNUCKLE- Driver | 1 | - | - |
| 90-4115 | STEERING KNUCKLE- Passenger | 1 | - | - |
| BOX 3 of 4-PN 59005/59005MX-3 | | | | |
| 90-3233 | REAR DROP BRACKET- (Driver) | 1 | 14,15,18,21 | 19,21,23 |
| 90-3210 | REAR DROP BRACKET- (Pass) | 1 | - | - |
| 90-3258 | REAR BUMP STOP- (Driver) | 1 | 17A,17B | 20 |
| 90-3261 | REAR BUMP STOP- (Pass) | 1 | - | - |
| 90-3213 | EVAPORATOR CAN DROP BRACKET | 1 | - | - |
| 7460 | HARDWARE PACK: Rear Brake Line | 2 | - | - |
| 7460-1 | BRAKE LINE-FRONT- TITAN W/CRUSH WASHER | 2 | 8 | 14 |
| 73-01000536 | 10-24 LOCK WASHER | 2 | 8 | 14 |
| 70-0100625000 | 10-24 X 5/8" ALLEN HEAD BOLT | 2 | 8 | 14 |
| 90-6319 | HARDWARE PACK: Zip Ties | 1 | - | - |
| 10999 | ZIP TIE, 11", BLACK | 12 | - | - |
| 90-3263 | REAR LOWER SHOCK MOUNT INNER-(Pass) | 1 | 20 | 22 |
| 90-3264 | REAR LOWER SHOCK MOUNT OUTER-(Pass) | 1 | 20 | 22 |
| 90-3265 | REAR LOWER SHOCK MOUNT INNER-(Driver) | 1 | - | - |
| 90-3266 | REAR LOWER SHOCK MOUNT OUTER-(Driver) | 1 | - | - |
| 90-6365 | HARDWARE PACK: Sway Bar Spacers | 1 | - | - |
| 60859H | 12MM I.D. SLEEVE | 2 | 9 | 15 |
| 90-2075 | 3/4" O.D. SPACER | 2 | 9 | 15 |
| 45359 | 5/8" HOURGLASS BUSHING | 4 | 9 | 15 |
| 61150 | SHOCK SLEEVE | 2 | 9 | 15 |
| 90-3118 | SWAY BAR SPACER PLATE | 2 | 9 | 15 |

| Part # | Description | Qty. | Illus. | Page |
|------------------------------|---|------|------------|-------|
| 90-3234 | ALUMINUM REAR DROP BRACKET | 2 | 16 | 20 |
| 90-6346 | HARDWARE PACK: Bump Stops | 2 | 17A | 20 |
| 15-11031 | CONE BUMP STOP - SHORT SHAFT | 2 | 17A | 20 |
| 73-03700034 | 3/8" SAE GR. 8 WASHER | 2 | 17A | 20 |
| 72-03700100512 | 3/8" USS GR. 5 NYLOC NUT | 2 | 17A | 20 |
| 90-6417 | HARDWARE PACK: Rear Bracket Spacers | 1 | - | - |
| 90-1539 | BRAKE LINE EXTENSION BRACKET | 2 | - | - |
| 90-2524 | UPPER SHOCK SPACER | 2 | 21 | 23 |
| 90-3256 | 3/8" DOUBLE BOLT PLATE | 4 | 20 | 22 |
| 10N62UHWZ | NO. 10-16 X 5/8" SHEETMETAL SCREWS | 2 | - | - |
| 90-6414 | HARDWARE PACK: Rear Brackets | 1 | - | - |
| 71-141701501000 | 14MM-1.5 X 170MM 10.9 HEX BOLT | 2 | 16 | 20 |
| 71-141701501000 | 14MM-1.5 X 30MM 10.9 HEX BOLT | 4 | 14 | 19 |
| 73-01410930 | 14MM HARDENED FLAT WASHER | 6 | 14,16 | 19,20 |
| 70-0371251800 | 3/8" X 1 1/4" GR. 8 BOLTS | 6 | 17A,17B | 20 |
| 70-0372751800 | 3/8" X 2 3/4" GR. 8 BOLTS | 4 | 18 | 21 |
| 72-037100816 | 3/8" STOVER NUT | 10 | 17A,17B,18 | 20,21 |
| 73-03700030 | 3/8" SAE GR. 8 WASHER | 20 | 17A,17B,18 | 20,21 |
| 72-052100816 | 9/16" STOVER NUT | 4 | 15 | 19 |
| 73-05200034 | 9/16" SAE GR. 8 HARDENED WASHER | 8 | 15 | 19 |
| 70-0562501800 | 9/16" X 2 1/2" GR. 8 BOLTS | 4 | 15 | 19 |
| 90-6415 | HARDWARE PACK: E-brake/ Evap. Canister | 1 | - | - |
| 70-0311001800 | 5/16" X 1" GR. 8 HEX BOLT | 2 | - | - |
| 72-031100816 | 5/16" STOVER NUT - (E-BRAKE DROPS) | 2 | - | - |
| 73-03110830 | 5/16" SAE GR. 8 FLAT WASHER | 4 | - | - |
| 70-0251001800 | 1/4" X 3/4" GR. 8 HEX BOLT | 1 | - | - |
| 72-02500816 | 1/4" STOVER NUT - (E-BRAKE DROPS) | 1 | - | - |
| 73-02500830 | 1/4" SAE GR. 8 FLAT WASHER | 2 | - | - |
| 90-6416 | HARDWARE PACK: Upper/Lower Rear Shock | 1 | - | - |
| 70-0503751800 | 1/2" X 3 3/4" GR. 8 HEX BOLT | 2 | 21 | 23 |
| 73-05000834 | 1/2" FLAT WASHER | 8 | 20,21 | 22,23 |
| 72-050100816 | 1/2" STOVER NUT | 4 | 20,21 | 22,23 |
| 70-0503001800 | 1/2" X 3" GR. 8 HEX BOLT | 2 | 20 | 22 |
| 72-037100512 | 3/8" FLAT WASHER | 8 | 20,21 | 22,23 |
| 73-03700830 | 3/8" STOVER NUT | 8 | 20,21 | 22,23 |
| 90-6410B | HARDWARE PACK: Cam Kit | 1 | - | - |
| 73-01410940 | 14MM FLAT WASHER | 8 | 6 | 12 |
| 72-01415008812 | 14MM NUT | 4 | 6 | 12 |
| 90-3245 | TITAN NOTCHED CAM | 4 | 6 | 12 |
| 90-3246 | TITAN CAM BOLT | 4 | 6 | 12 |
| BOX 4 of 4-PN 59005-4 | | | | |
| 918509 | 9000 SERIES REAR/REAR SHOCK | 2 | 20,21,22 | 22,23 |
| 924543 | 9000 SERIES REAR SHOCK | 2 | - | - |
| 90-2488 | COIL SPACER | 2 | 7b | 13 |
| 90-6429 | HARDWARE PACK: Rear Shocks | 1 | - | - |

| Part # | Description | Qty. | Illus. | Page |
|-----------------------------------|--|----------|------------------|-----------------|
| 73-06200030 | 5/8" SAE GR. 5 FLAT WASHER | 8 | - | - |
| 90-6071 | HARDWARE PACK: Rear Shock sleeves | 1 | - | - |
| 54314 | 1/2" X 5/8" X 1" SHOCK SLEEVE | 4 | - | - |
| 90-6340 | HARDWARE PACK: Sway Bar Drop Bottom | 2 | - | - |
| 70-0431251800 | 7/16" X 1 1/4" GR. 8 HEX BOLT | 4 | D | 28 |
| 73-04300034 | 7/16" HARDENED FLAT WASHER | 8 | D | 28 |
| 72-04300100816 | 7/16" GR. 8 STOVER NUT | 4 | D | 28 |
| 97-3321 | REAR CROSSMEMBER SUPPORT PLATE | 2 | A,B,C,D,E | 26,27,28 |
| 90-6299 | HARDWARE PACK: Spare Tire Guide Bracket | 2 | - | - |
| 70-0311001500 | 5/16" X 1" GR. 5 HEXBOLT | 2 | 23 | 24 |
| 72-03100100512 | 5/16" NYLOCK NUT | 2 | 23 | 24 |
| 73-03100030 | 5/16" SAE FLAT WASHER | 4 | 23 | 24 |
| 90-3293 | SAFETY LOOP EXTENSION BRACKET | 1 | 23 | 24 |
| 90-6168 | HARDWARE PACK: Safety Loop Extension | 1 | - | - |
| 71-1003015008802 | 10MM-1.5 X 30MM ALLEN BOLT | 2 | 23 | 24 |
| 72-01017508812 | 10MM-1.5 NYLOCK NUT | 2 | 23 | 24 |
| OR BOX 4 of 4-PN 59005MX-5 | | | | |
| 621000 | COIL OVER | 1 | 7a | 13 |
| 90-6071 | HARDWARE PACK: Rear Shock sleeves | 1 | - | - |
| 54314 | 1/2" X 5/8" X 1" SHOCK SLEEVE | 4 | - | - |
| 90-6168 | HARDWARE PACK: Safety Loop Extension | 1 | - | - |
| 71-1003015008802 | 10MM-1.5 X 30MM ALLEN BOLT | 2 | 23 | 24 |
| 72-01017508812 | 10MM-1.5 NYLOCK NUT | 2 | 23 | 24 |
| 90-6299 | HARDWARE PACK: Spare Tire Guide Bracket | 2 | - | - |
| 70-0311001500 | 5/16" X 1" GR. 5 HEXBOLT | 2 | 23 | 24 |
| 72-03100100512 | 5/16" NYLOCK NUT | 2 | 23 | 24 |
| 73-03100030 | 5/16" SAE FLAT WASHER | 4 | 23 | 24 |
| 90-6362 | HARDWARE PACK: Coil over mounting spacers | 1 | - | - |
| 90-2433 | UPPER SPACERS | 4 | 7a | 13 |
| 90-2494 | LOWER SPACERS | 4 | 7a | 13 |
| 90-3138 | COIL OVER MOUNT: UPPER BRACKET | 1 | 7a | 13 |
| 97-3321 | REAR CROSSMEMBER SUPPORT PLATE | 2 | A,B,C,D,E | 26,27,28 |
| 90-3293 | SAFETY LOOP EXTENSION BRACKET | 1 | 23 | 24 |
| 90-6317 | HARDWARE PACK: SPACER MOUNT | 1 | - | - |
| 72-043200810 | 7/16-20 GR. 8 PLATED HEX NUT | 6 | 7a,7b | 13 |
| 73-04300830 | 7/16 SAE FLATWASHER ZINC | 6 | 7a,7b | 13 |
| 73-04300836 | 7/16 SPLIT LOCK WASHER | 6 | 7a,7b | 13 |
| 90-6340 | HARDWARE PACK: Sway Bar Drop Bottom | 2 | - | - |

| Part # | Description | Qty. | Illus. | Page |
|--------------------------------|--|----------|-----------------|--------------|
| 70-0431251800 | 7/16" X 1 1/4" GR. 8 HEX BOLT | 4 | D | 28 |
| 73-04300034 | 7/16" HARDENED FLAT WASHER | 8 | D | 28 |
| 72-04300100816 | 7/16" GR. 8 STOVER NUT | 4 | D | 28 |
| MX6112 | MX6 REAR SHOCK-(stock Location) | 1 | - | - |
| 918509 | 9000 SERIES REAR/REAR SHOCK | 1 | 20,21,22 | 22,23 |
| 90-6429 | HARDWARE PACK: Rear Shocks | 1 | - | - |
| 73-06200030 | 5/8" SAE GR. 5 FLAT WASHER | 8 | - | - |
| BOX 5 of 5-PN 59005MX-5 | | | | |
| 621000 | COIL OVER | 1 | 7a | 13 |
| 90-3010 | COIL OVER WRENCH LARGE | 1 | - | - |
| 90-3011 | COIL OVER WRENCH SMALL | 1 | - | - |
| 90-6318 | HARDWARE PACK: Coil Over Mount | 1 | - | - |
| 70-0502751800 | 1/2"-13 X 2 3/4" BOLT | 2 | 7a | 13 |
| 73-05000830 | 1/2" SAE FLATWASHER ZINC | 4 | 7a | 13 |
| 72-050100816 | 1/2-13 UNITORQUE NUT GR. C Z | 2 | 7a | 13 |
| 90-3138 | COIL OVER MOUNT: Upper Bracket | 1 | 7a | 13 |
| MX6112 | MX6 REAR SHOCK-(stock Location) | 1 | - | - |
| 918509 | 9000 SERIES REAR/REAR SHOCK | 1 | 20,21,22 | 22,23 |

Equipment Available from your Pro Comp Distributor!

Coil Over Add On Kit:

59006BMX

Rear MX-6 Shocks:

MX6112

Also, Check out our outstanding selection of Pro Comp tires to compliment
your new installation!

Introduction:

- ◆ This installation requires a professional mechanic!
- ◆ We recommend that you have access to a factory service manual for your vehicle to assist in the disassembly and reassembly of your vehicle. It contains a wealth of detailed information.
- ◆ Prior to installation, carefully inspect the vehicle's steering and driveline systems paying close attention to the tie rod ends, ball joints, wheel bearing preload, pitman and idler arm. Additionally, check steering-to-frame and suspension-to-frame attaching points for stress cracks. The overall vehicle must be in excellent working condition. Repair or replace all worn or damaged parts!
- ◆ Read the instructions carefully and study the illustrations before attempting installation! You may save yourself a lot of extra work.
- ◆ Check the parts and hardware against the parts list to assure that your kit is complete. Separating parts according to the areas where they will be used and placing the hardware with the brackets before you begin will save installation time.
- ◆ Check the special equipment list and ensure the availability of these tools.
- ◆ Secure and properly block vehicle prior to beginning installation.
- ◆ ALWAYS wear safety glasses when using power tools or working under the vehicle!
- ◆ Use caution when cutting is required under the vehicle. The factory undercoating is flammable. Take appropriate precautions. Have a fire extinguisher close at hand.
- ◆ Foot pound torque readings are listed on the Torque Specifications chart at the end of the instructions. These are to be used unless specifically directed otherwise. Apply thread lock retaining compound where specified.
- ◆ **Please note that while every effort is made to ensure that the installation of your Pro Comp lift kit is a positive experience, variations in construction and assembly in the vehicle manufacturing process will virtually ensure that some parts may seem difficult to install. Additionally, the current trend in manufacturing of vehicles results in a frame that is highly flexible and may shift slightly on disassembly prior to installation. The use of pry bars and tapered punches for alignment is considered normal and usually does not indicate a faulty product. However, if you are uncertain about some aspect of the installation process, please feel free to call our tech support department at the number listed on the cover page. We do not recommend that you modify the Pro Comp parts in any way as this will void any warranty expressed or implied by the Pro Comp Suspension company.**

Important!

Due to differences in manufacturing, dimensions and inflated measurements, tire and wheel combinations should be test fit prior to installation. Tire and wheel choice is crucial in assuring proper fit, performance, and the safety of your Pro Comp equipped vehicle. For this application, a 17" wheel not to exceed 8" in width with a minimum backspacing of 4.5" to a maximum 5", additionally, a 17" X 9" wheel with 5" of backspacing is also acceptable. A quality tire of radial design, not exceeding 35" tall X 13.5" wide is recommended. Please note that the use of a 35" X 13.5" tire may require fender modification. Violation of these recommendations will not be endorsed as acceptable by Pro Comp Suspension and will void any and all warranties either written or implied.

IMPORTANT!: Not all 17" wheels will fit over the brake calipers. Be sure to test fit the wheels prior to purchase and installation.

NOTE: Factory installed side steps may contact the front wheels of the vehicle. Vehicles equipped with the factory side steps may need to have them removed.

Please Note:

- * Front suspension and head light realignment is necessary!
- * Speedometer and ABS recalibration will be necessary if larger tires (10% more than stock diameter) are installed.
- * Always use NEW cotter pins on re-assembly! (These items are NOT supplied)
- * **IT IS ADVISABLE THAT YOU HAVE HELP AVAILABLE WHEN INSTALLING THIS KIT. SOME COMPONENTS ARE HEAVY AND AWKWARD. ADDITIONAL HELP IS GOOD INSURANCE AGAINST INJURY!**

Special Tools:

Please refer to your service manual for more information.
A special removal tool is required for safe removal of the tie rods.
These tool may be purchased at your local Nissan dealer.
You may be able to rent any of these tools at your local parts store.

Front Installation:

1. Prior to installing this kit, with the vehicle on the ground. Measure the height of your vehicle. This measurement can be recorded from the center of the wheel, straight up to the top of the inner fender lip. Record the measurements below.

LF: _____ RF: _____

LR: _____ RR: _____

2. Ensure that your work space is of adequate size and the work surface is level. Place the vehicle in park. Place your floor jack under the front cross member and raise vehicle. Place jack stands under the frame rails behind the front wheel wells and lower the frame onto the stands. Remove the jack and place the vehicle back in gear, set the emergency brake, and place blocks both in front of and behind the rear wheels. Remove the front wheels.
3. Remove any skid plates if necessary.
4. Work on one side of the vehicle at a time.
5. Remove the sway bar. Remove the end links from the sway bar and discard. Save hardware for reuse.
6. Remove the brake caliper from the rotor and secure them clear from the work area. ***DO NOT*** let the caliper hang by the brake line or damage may result. Place an alignment mark on the rotor and the hub for reinstallation.
7. Remove the front rotors from the front hub.
8. Remove the nut from the end of the CV shaft in the hub. Remove the 6 bolts from the inner CV flange. Place an alignment mark on the CV and the differential mounting flange for reinstallation.
9. Unclip the ABS line from the knuckle and remove the anti-lock wiring and sensor

from the hub if applicable.

10. Using the appropriate tool, remove the tie rod end nut and separate from the knuckle.
11. Support the knuckle and remove the upper ball joint nut from the knuckle and separate using the appropriate tool.
12. Remove the C/V axle from the vehicle.
13. Remove the pinch bolt from the lower ball joint housing on spindle. Remove the knuckle from the vehicle.
14. Support the lower A-arm and remove the three nuts from the top of the coil over assembly and the one large nut and bolt on the bottom. Remove the coil-over from the vehicle. Save the hardware for reuse.
15. Remove the two bolts that retain the lower a-arm and remove it from the vehicle.
16. Repeat steps **6 through 15** on the other side of the vehicle.
17. Mark the front drive shaft orientation and unbolt it from the differential and secure it up clear of the work area.
18. Remove the rear crossmember brace. Retain the **(2)** passenger side bolts and nuts for reuse. See ILLUSTRATION 1.
19. Make sure that the front differential is well supported, remove existing hardware from both passenger and driver side differential mounting areas. Carefully lower differential out of vehicle and set aside. Note the differential vent tube routing for reinstallation. Be careful the differential is heavy. Save the two front mount bolts for reuse.

NOTE: If you have a truck with nut plates in the frame instead of nuts on the differential bolts, use the nuts off the rear U-bolts as a replacement.

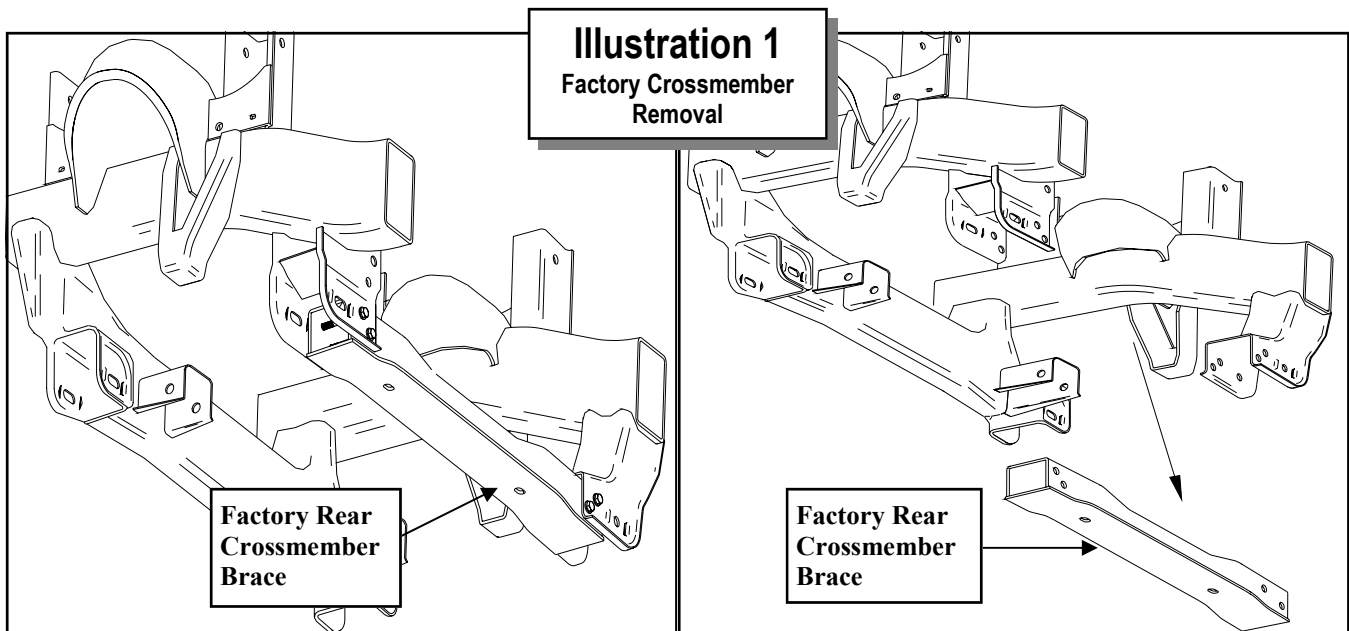

20. Install the front cross member (**90-3125**) into original front A-arm mounting locations, using the supplied **9/16 X 4 1/2"** bolts, cam block off plates (**90-3137**) and hardware with the heads to the front, leave loose. See ILLUSTRATION 2.

NOTE: Make sure all cam block off plates are installed with the notch in the block off plate facing in the same direction.

21. Support the differential with a jack and reinstall into the front differential mounts on the new front crossmember. Secure using previously removed **OE** hardware. Do not tighten at this time. See ILLUSTRATION 3.

NOTE: Bend outward the front passenger differential mount tabs if they appear close to the CV mounting flange on the differential.

22. Install the new rear cross member (**90-3132**) by guiding the rear differential mount into place on the drivers side. Insert the supplied **9/16" X 4 1/2"** bolts and cam block off plates (**90-3137**) into the A-Arm pockets with the heads to the rear. **On passenger side only** reinstall (2) **OE** crossmember brace bolts through holes

in rear crossmember. See ILLUSTRATION 4. Do not tighten at this time.

23. Install rear differential **14mm X 1.5 X 100mm** bolt and **14mm** washer with the head facing the rear of the vehicle. Insert (2) "C" washer (**90-3117**) on each side of the bolt with the flat side butted up against the frame. The **OE** nut will be reused. See ILLUSTRATION 5. Do not tighten at this time.

NOTE: If in some vehicles the "C"

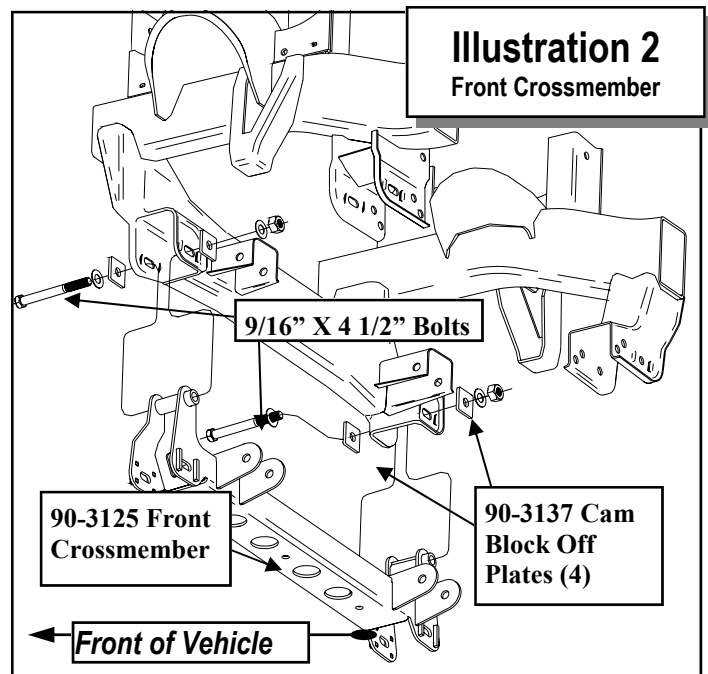

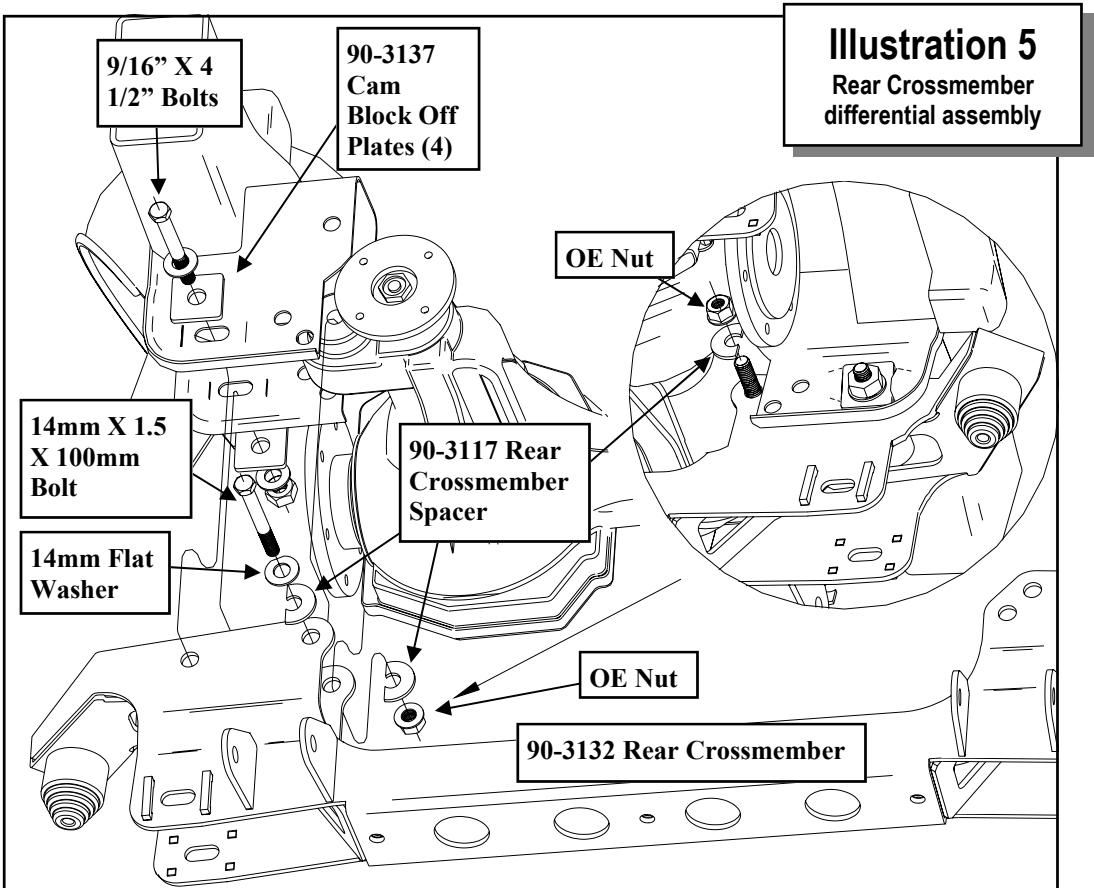
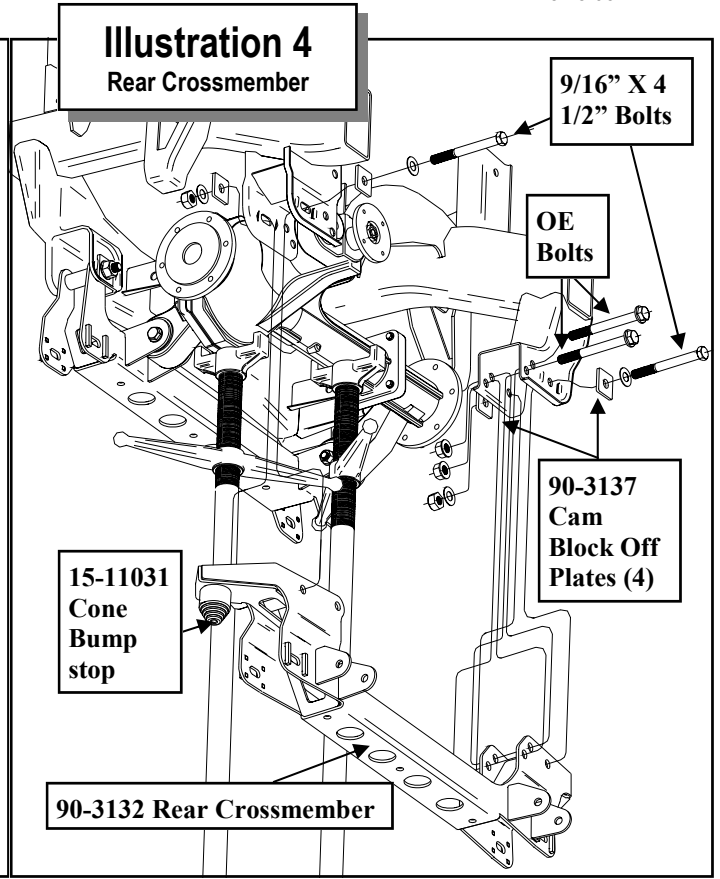
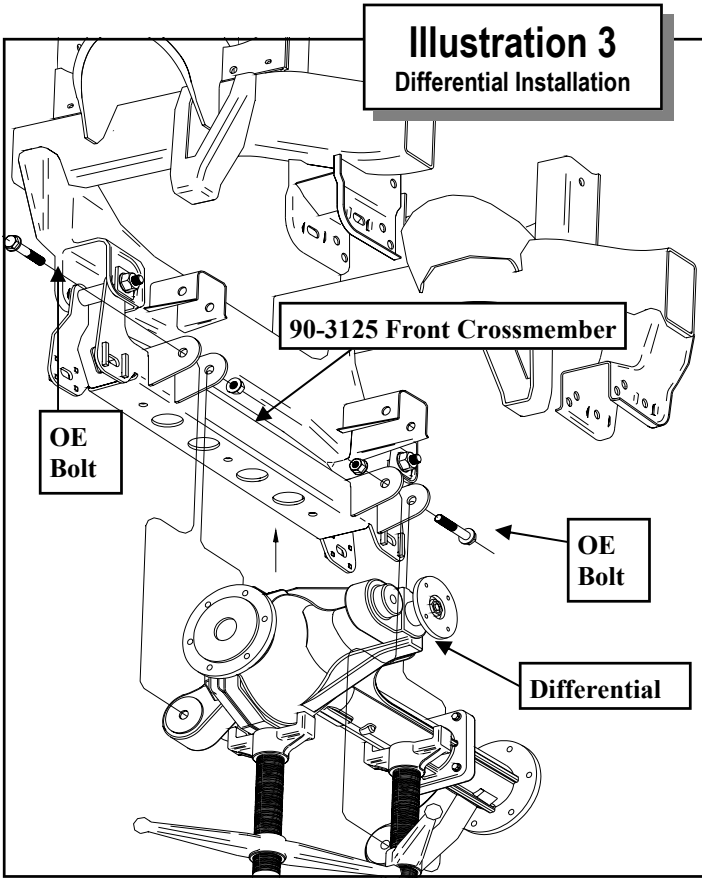

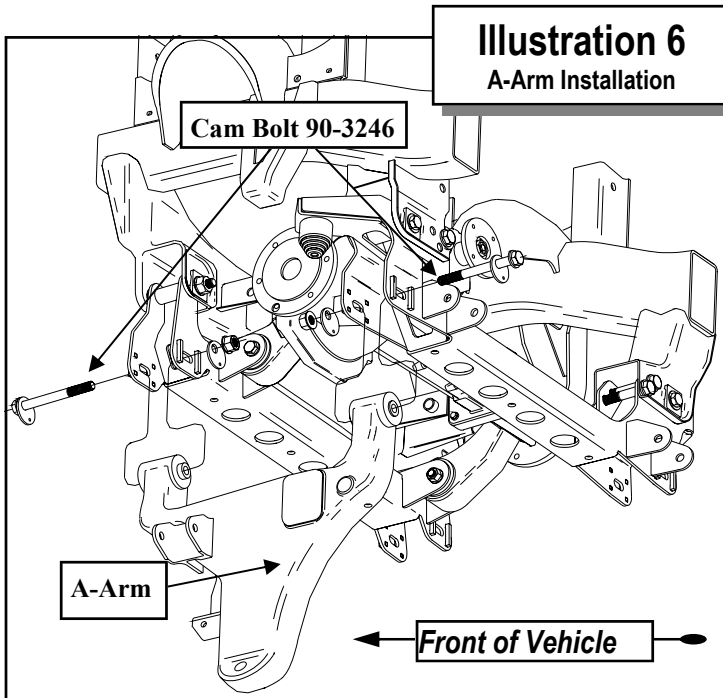

Illustration 6

A-Arm Installation

washer (90-3117) does not fit perfectly, it can be ground down to fit.

24. Install bump stops (15-11031) into rear crossmember using 3/8" hardware from hardware pack (90-6346).
25. Reconnect and route the differential vent hose as previously noted. Use the supplied zip ties to secure the hose.
26. Line up the previously applied marks and reinstall the front driveshaft.
27. Install the lower a-arms into the new cross members with the cam bolts (90-3246) from pack (90-6410B). The cams should fit between the cam guides on the cross members. See ILLUSTRATION 6. **Do not tighten until wheels are on and vehicle is on the ground.**
28. Torque the front and rear Pro Comp cross member mounting bolts to 105 ft./lbs.
29. Tighten all of the remaining hardware to factory specifications.
30. **WITH THE COIL OVERS.** Insert the mono ball spacers (90-2433) from pack (90-6362) in the top of the coil over as shown in ILLUSTRATION 7a.

31. Insert the mono ball spacers (90-2494) from pack (90-6362) in the bottom of the coil over as shown in ILLUSTRATION 7a.

NOTE: The spacers are a tight fit. A press might be needed to fit the spacers into the mono balls.

32. Install the new Pro-Comp coil over shock (621000) to the upper bracket (90-3138) with the supplied 1/2" X 2 3/4" hardware from hardware pack (90-6318). Fasten upper bracket to truck using the supplied 7/16" hardware on the top from hardware pack (90-6317) and torque to 45-50ft./lbs. See ILLUSTRATION 7a.

NOTE: Supplemental Instructions for MX kit Coil Over Installation are located in box 59005BMX-4.

33. **WITH THE COIL SPACERS.** Attach the shock spacer (90-2488) to the top of the shock using the OE hardware. Torque to 22 ft./lbs. Fit the shock and spacer into the stock mounting locations. Fasten using the supplied hardware on the top from hardware pack (90-6317) torque to 45-50ft./lbs. See ILLUSTRATION 7b.
34. Install the OE bolt through the lower shock mount and a-arm. Torque to 99 ft./lbs.
35. Transfer all the parts from the factory knuckles to the supplied Pro-Comp knuckles.

NOTE: Tighten all the factory hardware carefully. Be sure to follow the factory assembly procedures and torque the 3 wheel hub mounting bolts to 155 ft./lbs.

36. Support lower A-arms. Position the new front knuckles (90-4114 driver and 90-4115 passenger). Attach the knuckle to lower ball joint. Install pinch bolt and torque to 70 ft./lbs.
37. Slide the CV through the knuckle from the rear. Attach the nut to the end of the CV shaft. Torque to 101 ft./lbs. Install

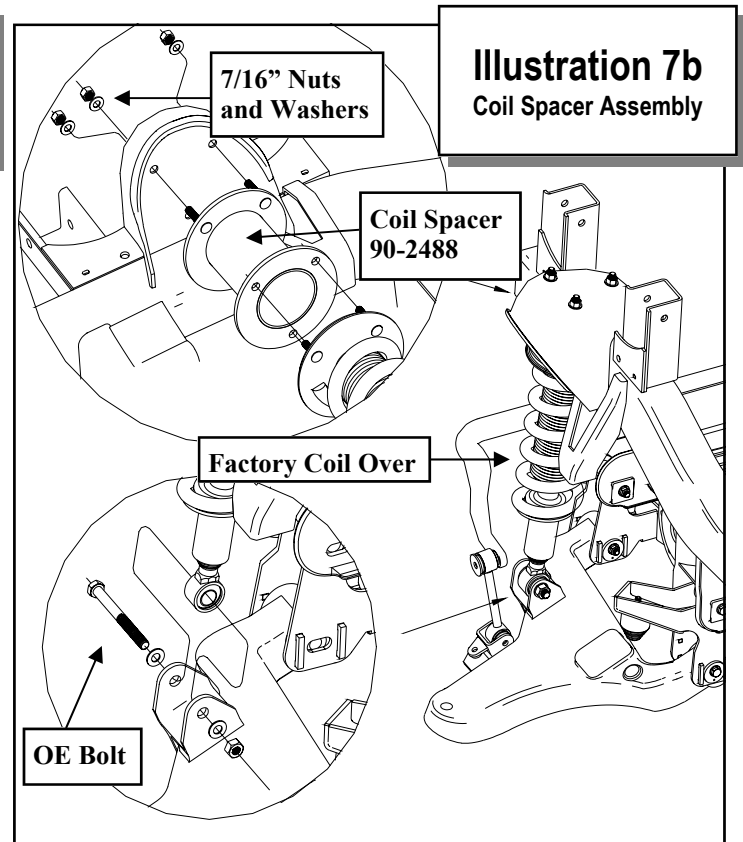
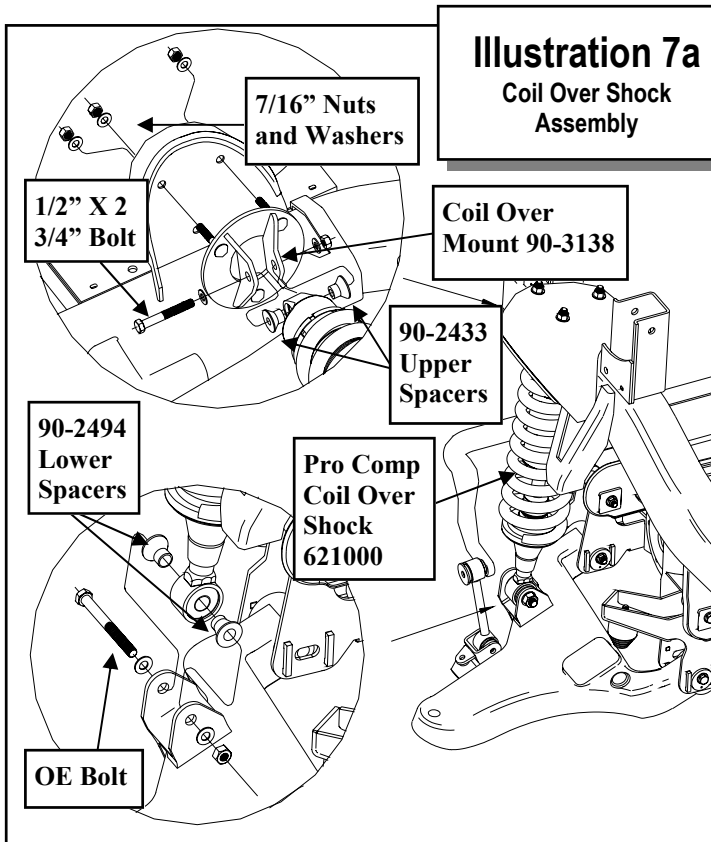

new cotter pin and reattach dust cap.

38. Attach the CV axles to the differential and use thread locking compound and torque to 54 ft./lbs.
39. Attach the knuckle to the upper ball joint. Torque to 58 ft./lbs.
40. The driver side tie rod end and the passenger side tie rod end need to be exchanged to provide adequate tire clearance.
41. On driver side, loosen the lock nut and remove the tie rod end.
42. On passenger side, loosen the lock nut and remove the tie rod end.

NOTE: Be sure to note the position of the lock nut, before you loosen it, for proper tie rod reinstallation.

43. Install the previously removed driver side tie rod end on to the passenger side. Thread tie rod on until it is in its original location on the steering rack shaft with

the stud facing down.

44. Install the previously removed passenger side tie rod end on to the driver side. Thread tie rod on until it is in its original location on the steering rack shaft with the stud facing down.
45. Re-lock the newly installed tie rod ends with the **OE** lock nut.
46. Insert from the top and fasten tie rod end to the knuckle and torque to 63 ft./lbs.
47. Connect the anti-lock wiring harness and sensor to the hub if applicable.
48. Repeat the installation on the other side of the vehicle.
49. Install the front rotors on to the front hubs.
50. At the driver side, install the brake caliper and locate the rubber brake hose that runs from caliper to frame. Pinch it closed with vise grips or a small "C" clamp and detach it from the caliper Plug

Illustration 8

Front Brake Line Bracket
Typical Routing Shown

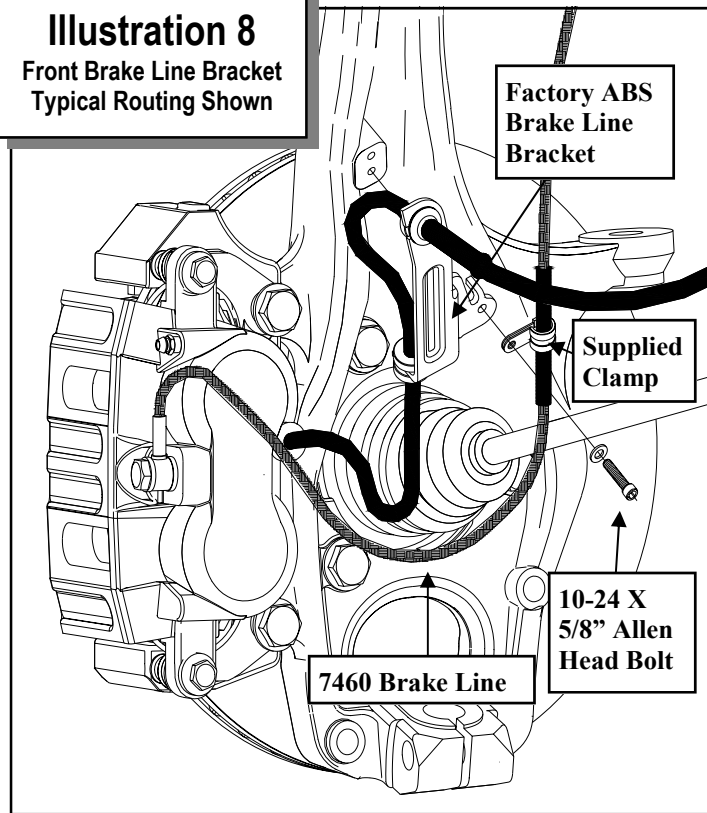

or cover the caliper opening and remove the brake line from the vehicle.

51. Thoroughly clean all mating surfaces and install the supplied stainless steel brake line (**PN 7460**). At the upper end of the brake line install the supplied jam nut to threaded end of the brake line. The U-shaped clip will not be reused. Insert the threaded end of the brake line from the bottom through factory mounting bracket. Attach the Pro Comp brake line to the factory metal brake line and tighten. Install the brake line to the caliper using the factory banjo bolt and new crush washer. Position the line so it doesn't make contact with any other parts. Make sure brake lines are clean and dry of any material before ABS brake bleeding.
52. Bend flat the factory ABS bracket. Place supplied clamps from hardware pack (**7460**) around the new brake lines. Secure the ABS bracket and brake line clamp to the new spindle using the provided **10-24 X 5/8"** Allen head bolt and

lock washer. See ILLUSTRATION 8.

53. Repeat on the remaining side of vehicle.

BLEEDING OF THE BRAKE SYSTEM SHOULD BE DONE ACCORDING TO NISSAN ARMADA FACTORY SERVICE MANUAL.

IMPORTANT: BE VERY CAREFUL NOT TO LET THE MASTER CYLINDER RUN DRY! WITH ABS BRAKES THIS SITUATION WILL DAMAGE THE SYSTEM!

IMPORTANT: Move the A-arm assembly up and down to its limits several times to check for binding and to ensure that there are no interference or pinching problems with the brake lines and ABS wiring.

54. Assemble sway bar end links (**90-2481**) using (**2**) **5/8"** hourglass bushings (**45359**), **12mm** sleeve (**60859H**) and **3/8"** sleeve (**61150**). See ILLUSTRATION 9, STEP 1.
55. Fasten Sway Bar adapter (**90-3119 DRVR** and **90-3122 PASS**) to the sway bar end link (**90-2481**) using the **3/8" X 2 1/2"** bolt and hardware. See ILLUSTRATION 9, STEP 1.

NOTE: Make sure to place the angled ends of the sway bar end link toward the sway bar.

56. Install the sway bar assembly to the A-Arm first using **5/16 X 1 1/4"** bolt and spacer (**90-2075**). Insert the steering stop reinforcement plate (**97-3284**) underneath the sway bar end link mounting tab. Secure using the **5/16"** hardware. See ILLUSTRATION 9, STEP 2. Do not tighten at this time.

NOTE: The steering stop reinforcement plate (97-3284) MUST be welded in place to the sway bar end link mounting tab.

57. Insert the **7/16" X 1 1/4"** bolt in the re-

Illustration 9 Sway Bar End Link Assembly Driver Side

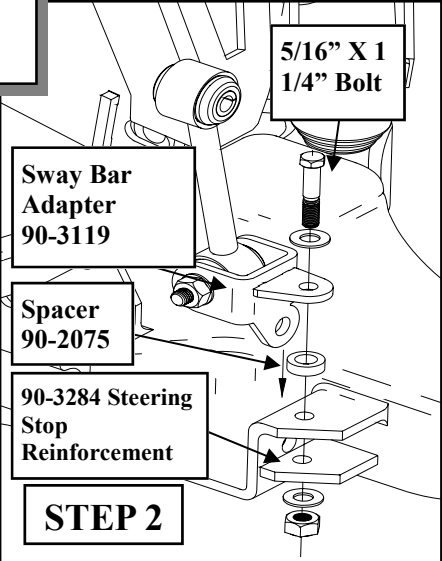
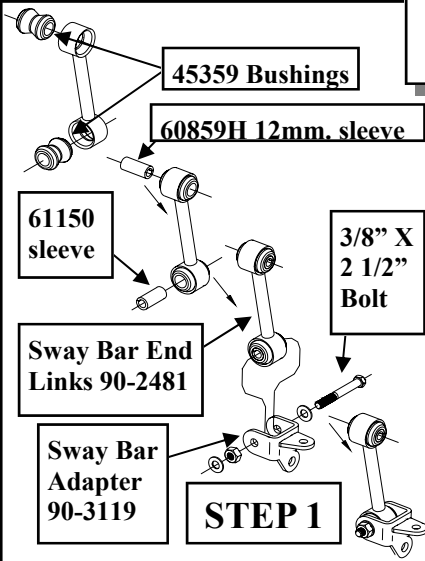

FINISHED ASSEMBLY

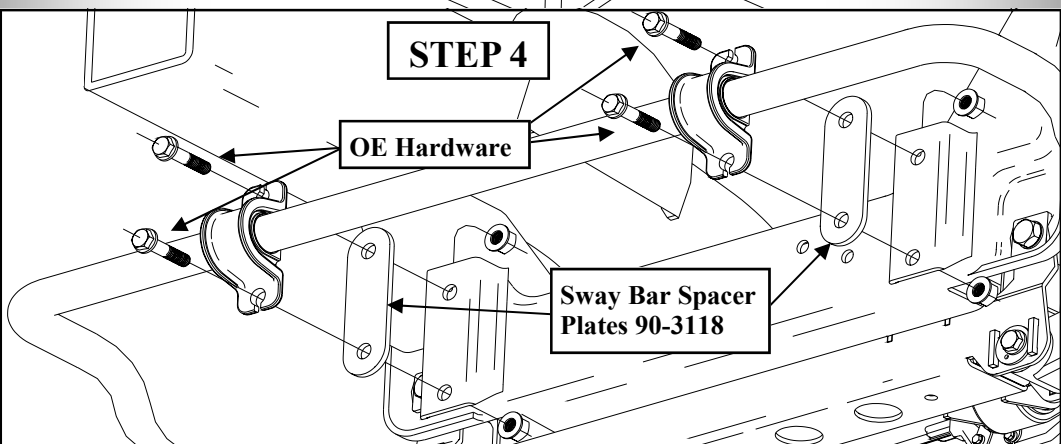
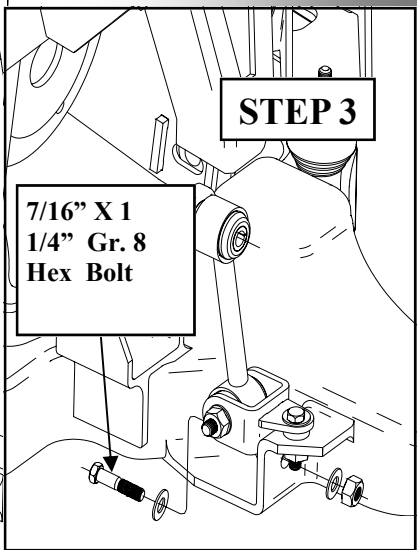
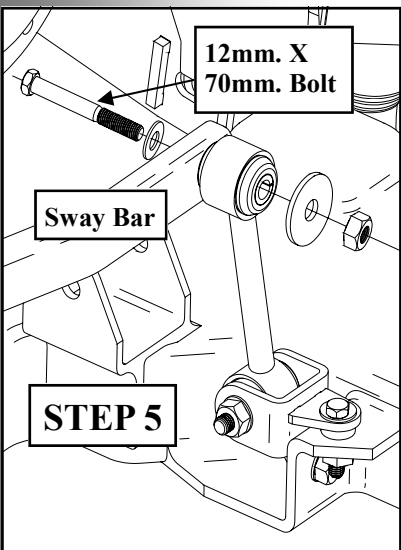

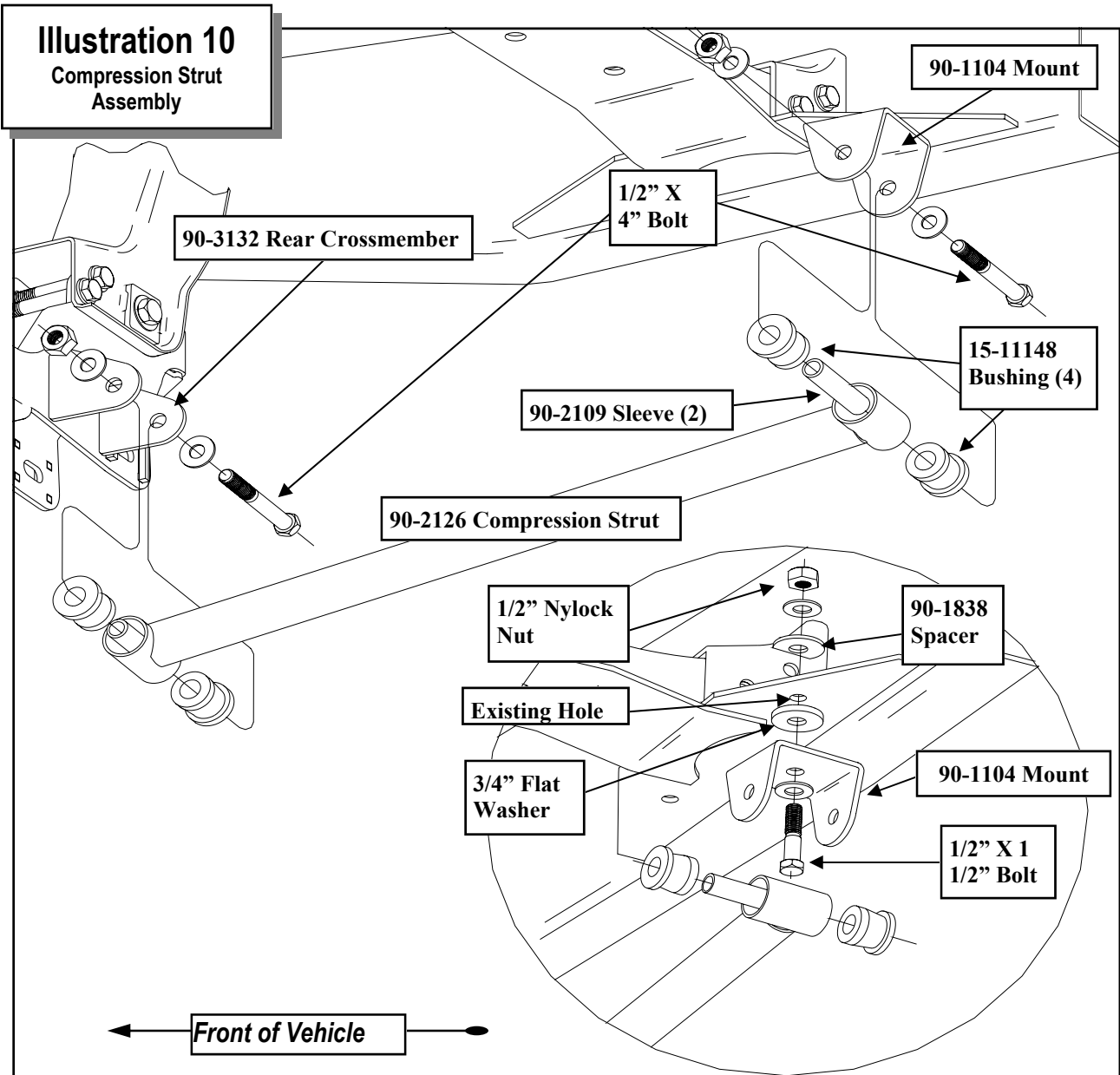

maintaining lower hole in the sway bar adapter. See ILLUSTRATION 9, STEP 3. Tighten the 7/16" bolt first and the 5/16" second.

58. Insert sway bar spacer plate (90-3118) in between the mount and the frame and reinstall sway bar using OE hardware. Torque bolts to 94 ft./lbs. See ILLUSTRATION 9, STEP 4.
59. Using the 12mm X 70mm bolt, fasten sway bar end link to sway bar. See ILLUSTRATION 9, STEP 5.

NOTE: The head of the 12mm. bolt must be facing toward the center of the vehicle or it will contact the coil-over shock.

60. Torque sway bar hardware to proper specifications.
61. Repeat on the opposite side of the vehicle.
62. Install the bushings (15-11148) and sleeves (90-2109) from hardware pack (90-6263) into the compression struts (90-2126).

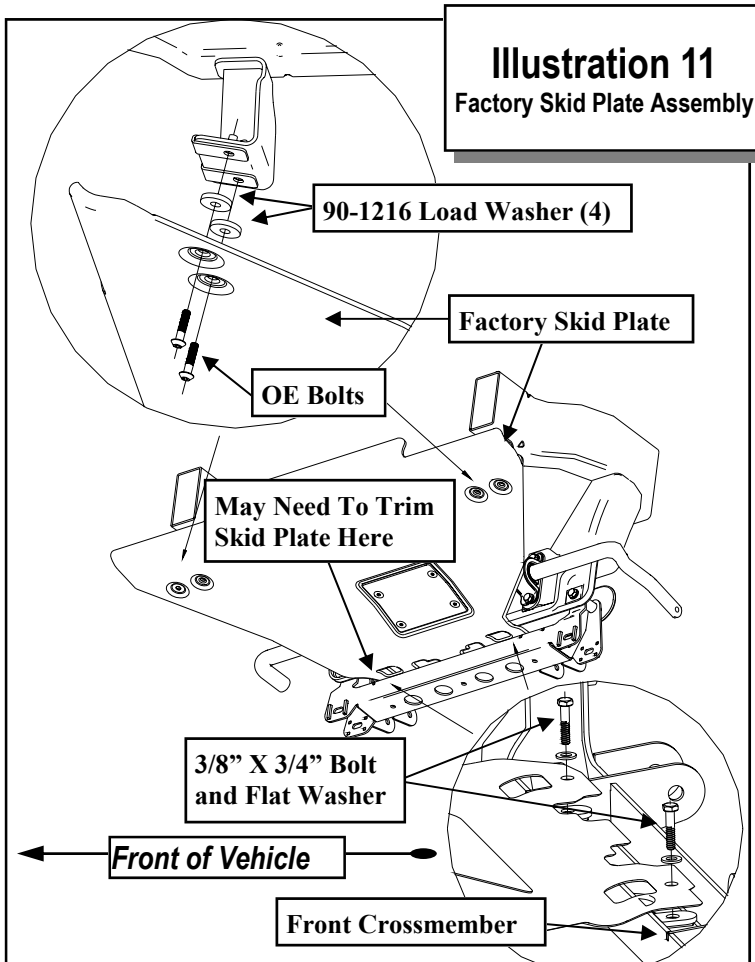

Illustration 11
Factory Skid Plate Assembly

the vehicle to the ground. Torque to factory specifications.

69. If Reinstalling factory skid plate do so at this time. Fasten the skid plate to the front factory brackets using (4) spacer (90-1216) and OE bolts. Fasten rear of plate to the front crossmember tabs using the 3/8" X 3/4" bolts and washers. See ILLUSTRATION 11.

NOTE: The factory skid plate requires minor trimming near the passenger side crossmember mount to clear crossmember.

70. Torque lower a-arm cam bolts to 103 ft./lbs.

71. On both sides of the vehicle, check the routing of the brake lines and the ABS wire harnesses. There must be no pinching, rubbing, or stretching of either component. Use zip ties to secure these items to the steering components. At full droop, cycle the steering from lock to lock while observing the reaction of these components. Reposition them if needed.

63. See ILLUSTRATION 10.

64. Install compression struts into mounts on the rear cross member (90-3132) using supplied 1/2" X 4" hardware. See ILLUSTRATION 10.

65. Using the existing hole attach the compression strut mounts (90-1104) to the transmission crossmember gusset. Use the supplied 3/4" USS washer, notched spacer (90-1838), 1/2" X 1 1/2" bolt and hardware to secure the mounts to the crossmember. See ILLUSTRATION 10.

66. Rotate the compression struts up and secure them to the mounts using the supplied 1/2" X 4" bolt and hardware. See ILLUSTRATION 10.

67. Recheck all hardware for proper installation and torque at this time.

68. Reinstall the wheels and tires and lower

NOTES:

- ⇒ On completion of the installation, have the suspension and headlights re-aligned.
- ⇒ After 100 miles recheck for proper torque on all newly installed hardware.
- ⇒ Recheck all hardware for tightness after off road use.

Rear Installation:

1. Block the front tires and raise the rear of the vehicle. Support the frame with jack stands forward of the rear subframe assembly.
2. Remove the rear wheels.
3. Consult the factory manual and remove the spare tire from underneath the vehicle.
4. Unbolt the spare tire guide bracket from the rear crossmember. Save for reinstallation.
5. Unbolt the rear safety bracket from the rear sub frame assembly. Save bracket and hardware for reinstallation.
6. Unbolt evaporator canister from the sub frame assembly. Save bolt for reuse.
7. Unbolt the emergency brake line brackets from the frame above the driveshaft.
8. Remove the factory bump stops from the frame.
9. Drill out the hole in the existing bump stop mounting hole using a **3/8"** drill bit. See ILLUSTRATION 12.
10. Remove the shocks on both sides of the vehicle. It may be necessary that you slightly raise each control arm to unload the shocks for removal.
11. Locate the rubber brake hose that runs from caliper to frame and detach it from the caliper. Pinch the line closed with vise grips or a small "C" clamp. Plug or cover the caliper opening.
12. Unclip the ABS lines from the frame move out of the work area.
13. Unclip the evaporator hose and carefully cut the evaporator hose clip bracket from the rear sub frame assembly. Be sure to grind the frame smooth after removal. See ILLUSTRATION 13.
14. Support the rear suspension assembly

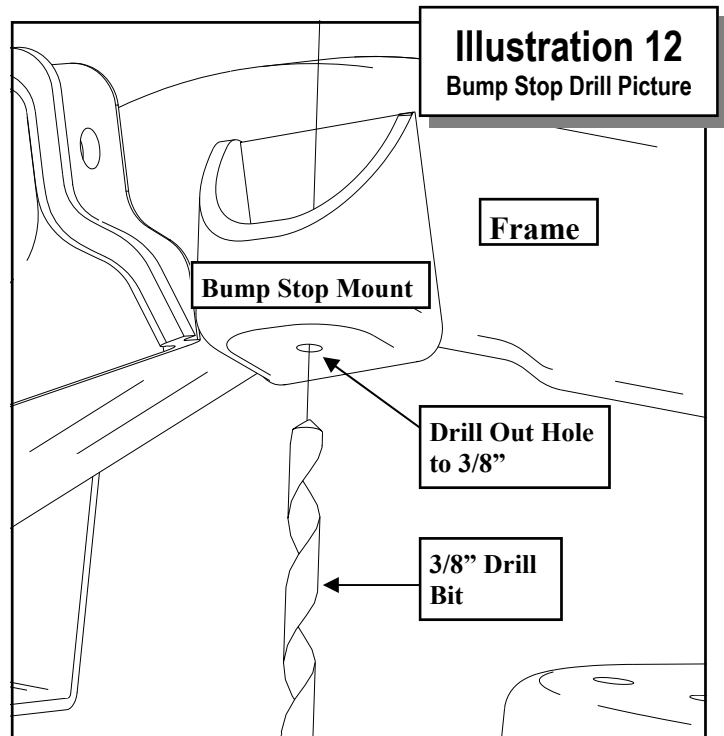

with floor jacks. Unbolt the entire rear assembly from the frame and lower it to allow for installation of the rear brackets. Support assembly with jack stands.

15. Bolt the rear drop brackets (**90-3233 Driver and 90-3210 Pass**) to the frame using the supplied **14mm X 30mm** bolts and hardware. See ILLUSTRATION 14. Do not tighten at this time.
16. Raise the rear sub frame assembly and fasten to the rear drop brackets using the supplied **(4) 9/16" X 2 1/2"** bolts and hardware. See ILLUSTRATION 15. Do

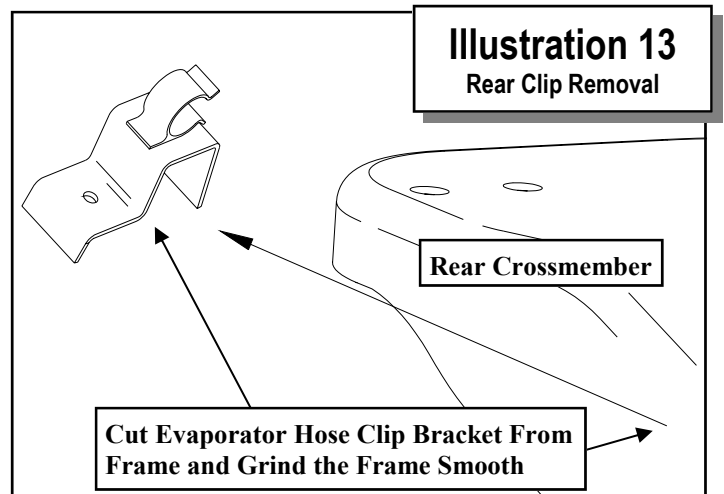

Illustration 14
Rear Assembly to Frame
Install Driver Side

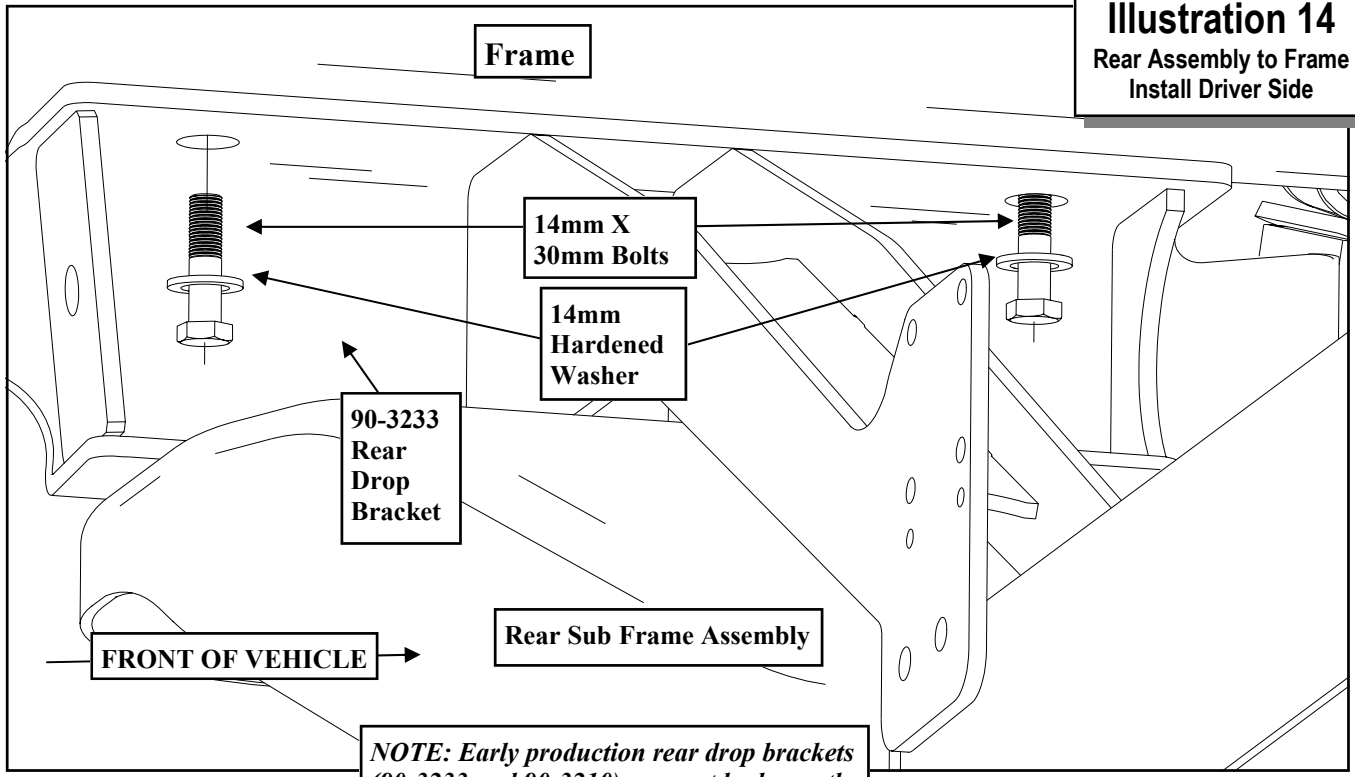
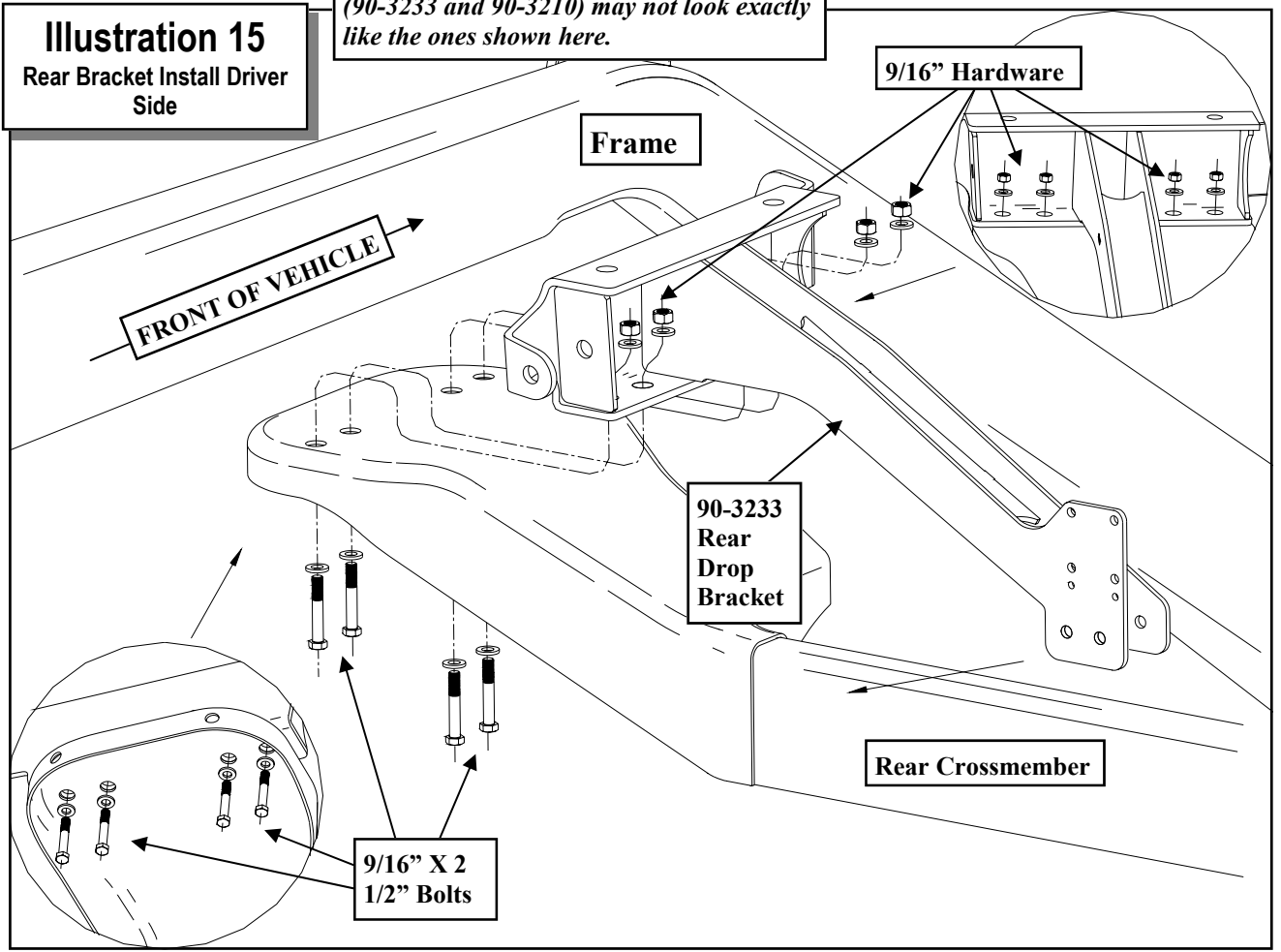
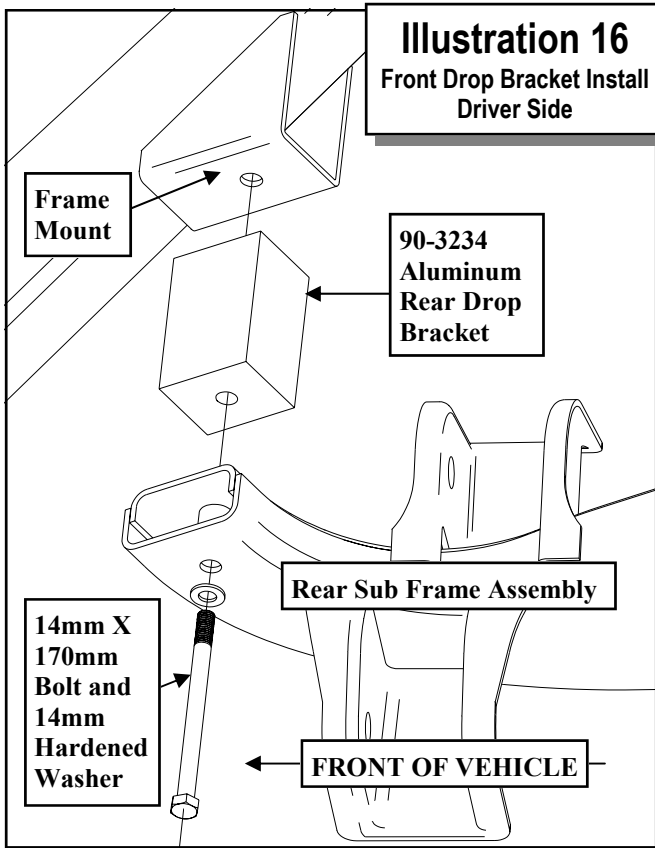

Illustration 15
Rear Bracket Install Driver Side





not tighten at this time.

17. Insert the Aluminum rear drop brackets (90-3234) and secure using the supplied 14mm X 170mm bolts. See ILLUSTRATION 16. Do not tighten at this time.
18. Loosely attach the bump stop extensions (90-3258 pass 90-3261 driver) to the frame using the 3/8" X 1 1/4" bolts and loosely secure the extensions to the rear bracket using the supplied 3/8" X 1 1/4" bolts. See ILLUSTRATION 17a & 17b.
19. Install the supplied bump stops (15-11031) to the drop brackets using the supplied 3/8" hardware.
20. Torque all new rear sub frame assembly drop bracket hardware according to the torque chart on page 29.
21. Using the rear bracket support arms (90-3233 driver and 90-3210 pass) as a template, center punch the holes in the rear subframe crossmember.

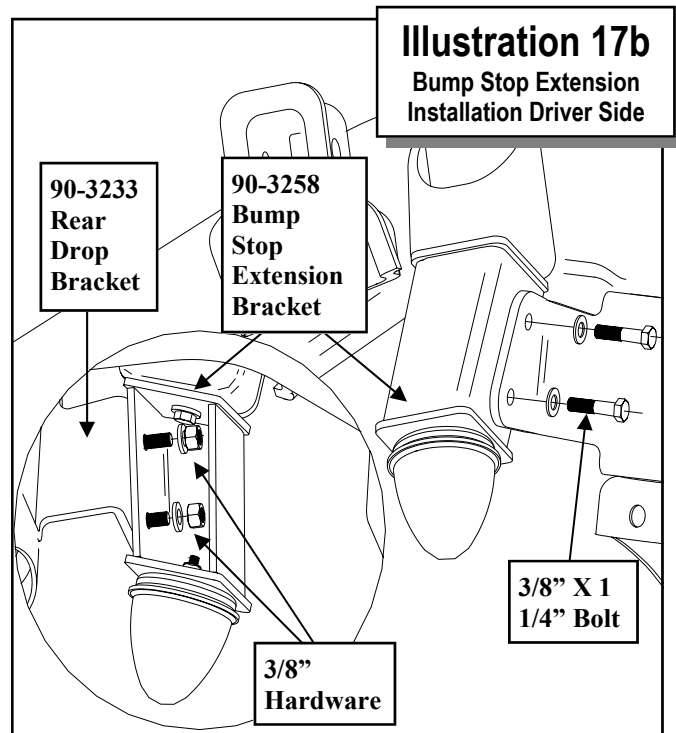
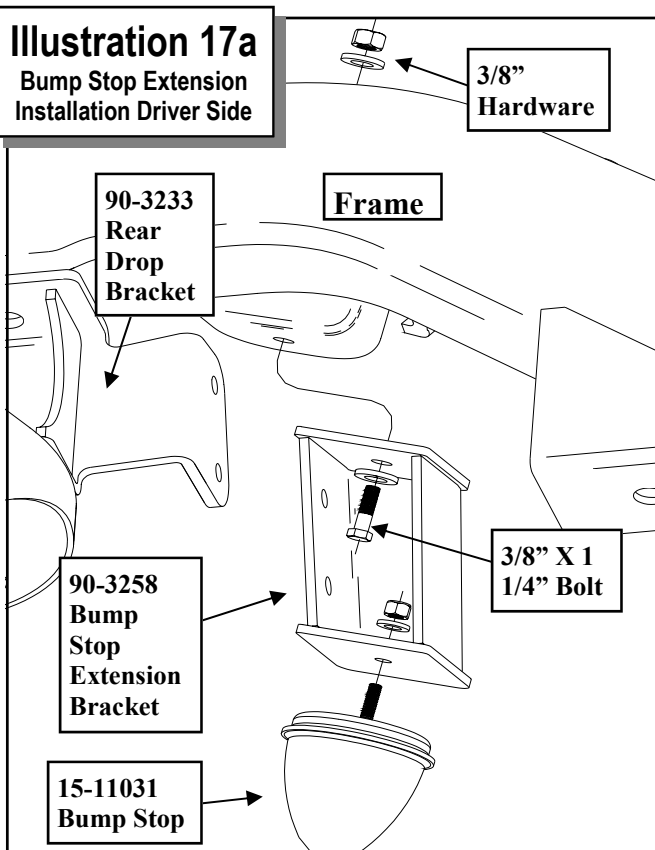

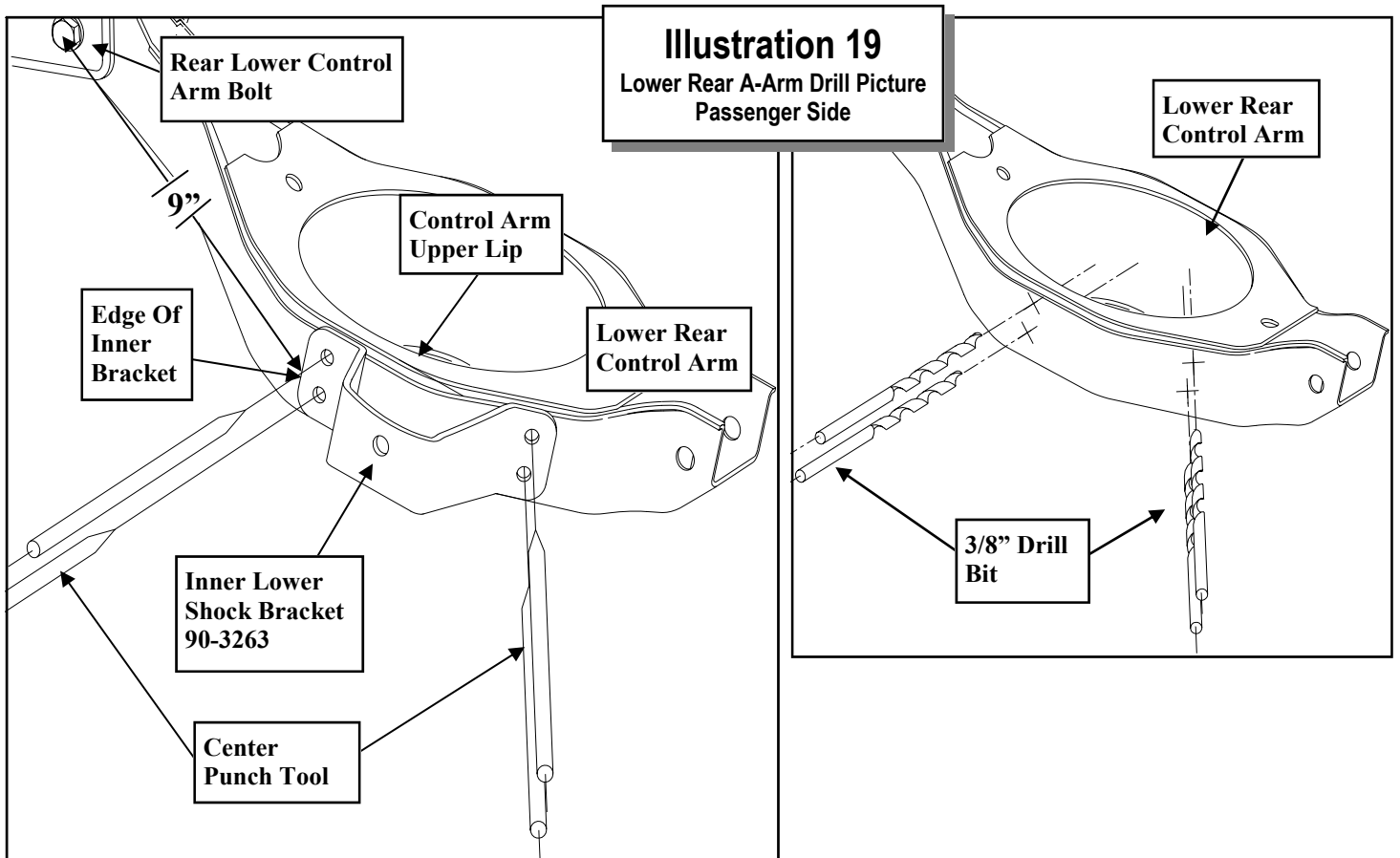
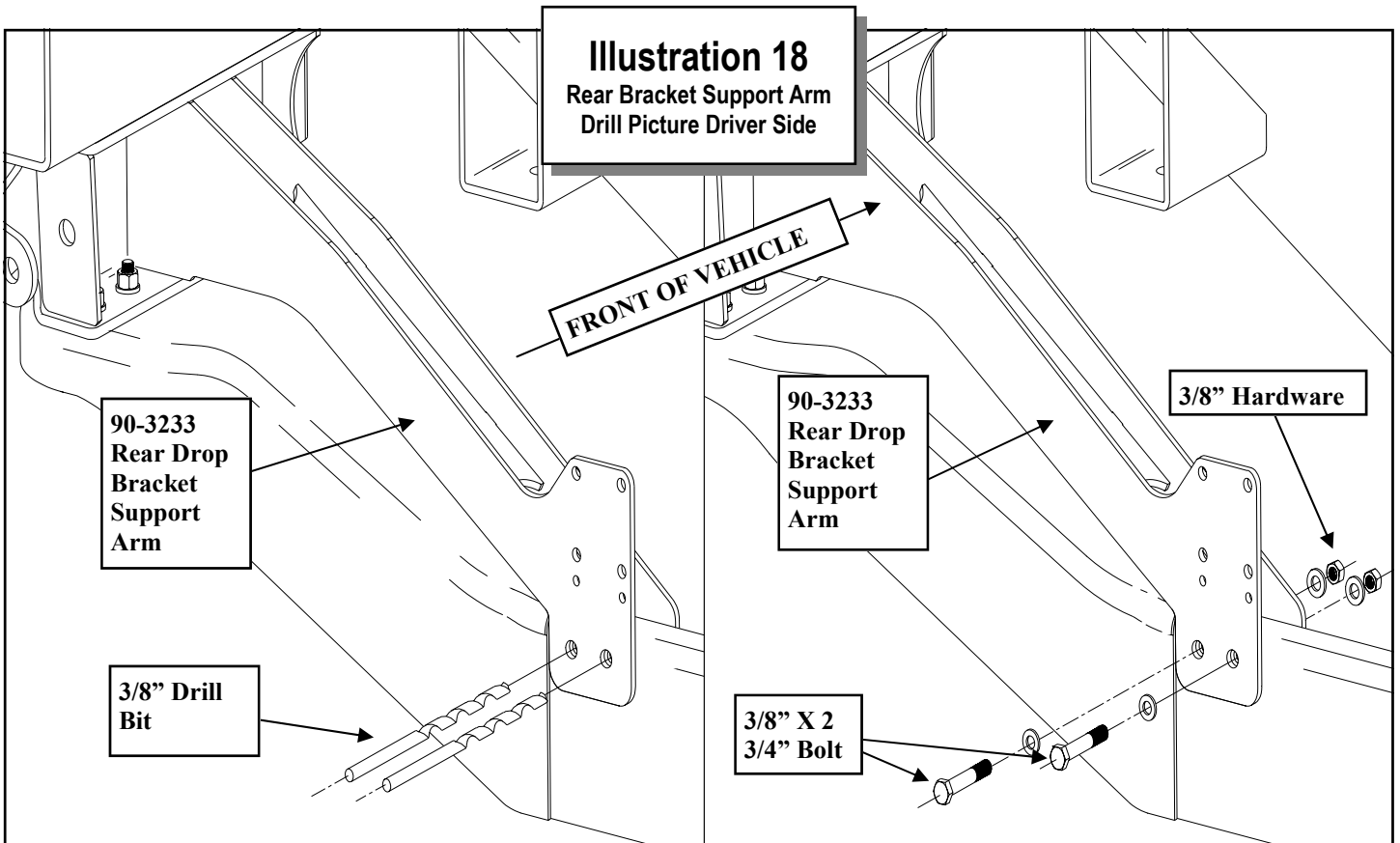

- 22. Drill the previously marked holes using a **3/8"** drill bit. See ILLUSTRATION 18.
- 23. Bolt the rear bracket support arms to the rear crossmember using the **(4)** supplied **3/8" X 2 3/4"** bolts. See ILLUSTRATION 18.
- 24. Torque the new rear bracket support hardware according to the torque chart on page 29.
- 25. Bolt the evaporator canister drop bracket **(90-3213)** to the sub frame assembly using the previously removed **OE** bolt.
- 26. Bolt the drop bracket to the evaporator canister using the supplied **1/4" X 3/4"** bolt and hardware.
- 27. Using the **OE** bolts, install the **(2)** emergency brake cable drop brackets **(90-1539)** to the frame. Secure the emergency cable brackets to the new drop

brackets **(90-1539)** using supplied **5/16" X 1"** bolts and hardware.

- 28. On the driver's side, detach the rubber brake line from the factory metal brake line and remove it from the vehicle.
- 29. Thoroughly clean all mating surfaces and install the supplied stainless steel brake line **(PN 7460)**. At the upper end of the brake line install the supplied jam nut to threaded end of the brake line. The U-shaped clip will not be reused. Insert the threaded end of the brake line from the bottom through factory mounting bracket. Attach the Pro Comp brake line to the factory metal brake line and tighten. Install the brake line to the caliper using the factory banjo bolt and new crush washer. Position the line so it doesn't make contact with any other parts. Make sure brake lines are clean and dry of any material before ABS brake bleeding.

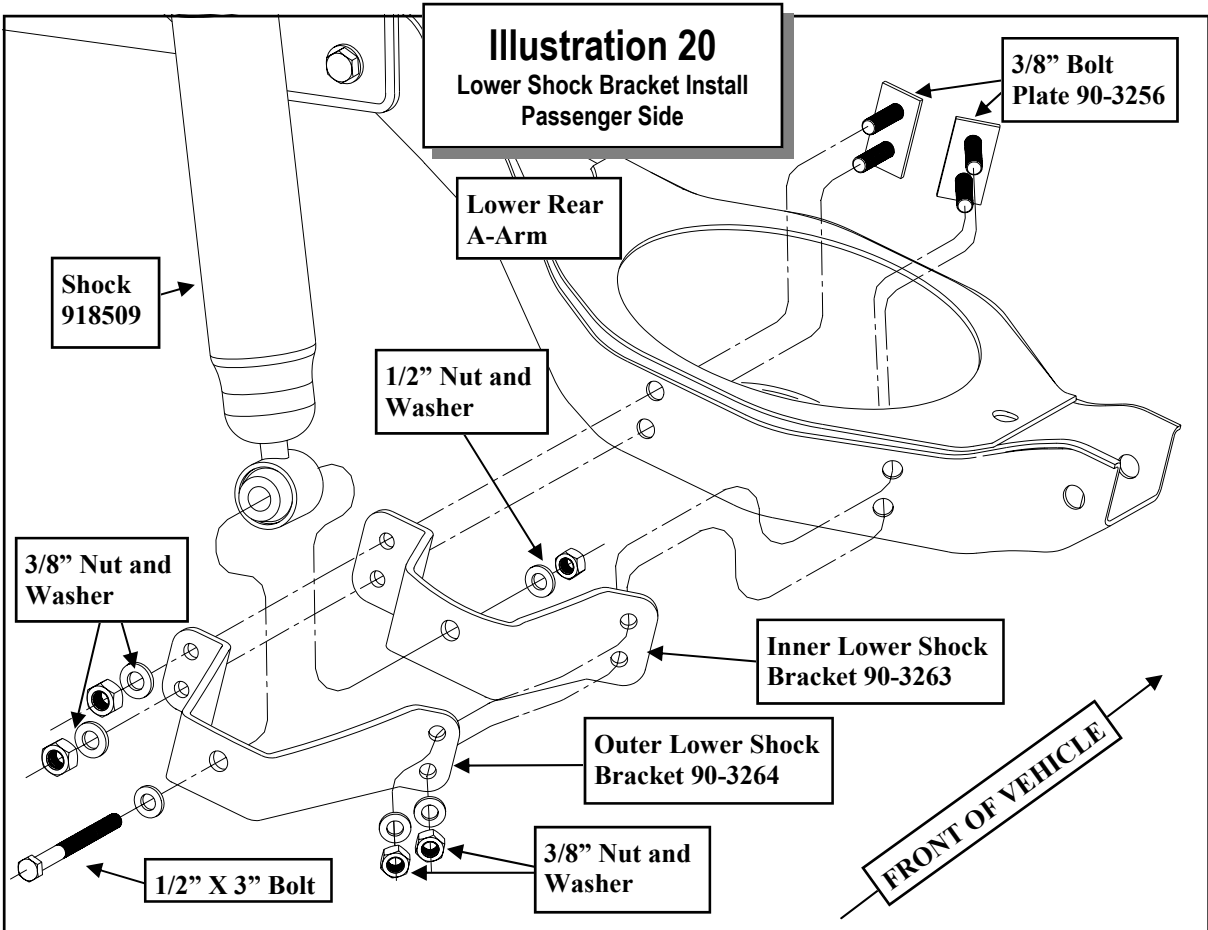

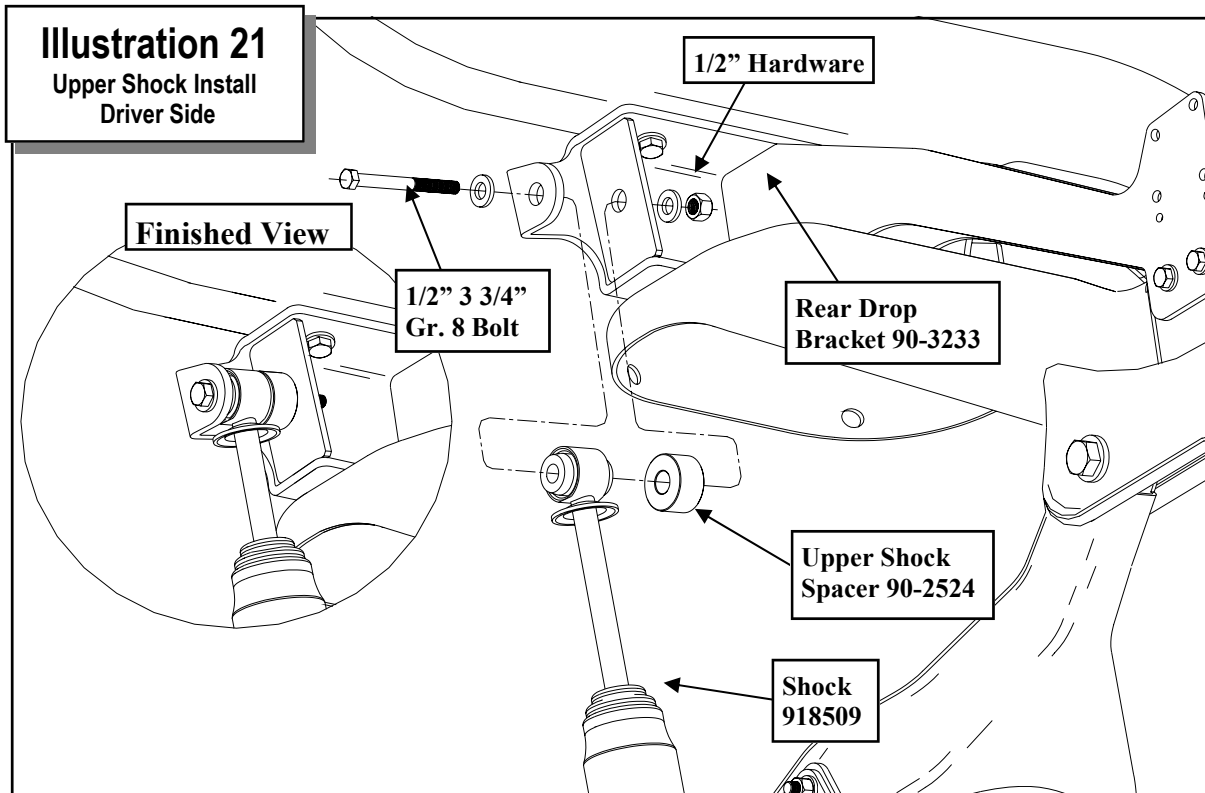

30. Secure the rear brake line to the upper rear control arm using the supplied Adel clamp and sheet metal screw (10N62UHWZ) from pack (90-6417).

NOTE: Be sure to position the protective rubber brake line sleeve under the Adel clamp to prevent rubbing of the steel brake line.

31. Repeat on the remaining side of vehicle.

BLEEDING OF THE BRAKE SYSTEM SHOULD BE DONE ACCORDING TO NISSAN ARMADA FACTORY SERVICE MANUAL.

IMPORTANT: BE VERY CAREFUL NOT TO LET THE MASTER CYLINDER RUN DRY! WITH ABS BRAKES THIS SITUATION WILL DAMAGE THE SYSTEM!

IMPORTANT: MOVE THE A-ARM ASSEMBLY UP AND DOWN TO ITS LIMITS SEVERAL TIMES TO CHECK FOR BINDING AND TO ENSURE THAT THERE ARE NO INTERFERENCE OR

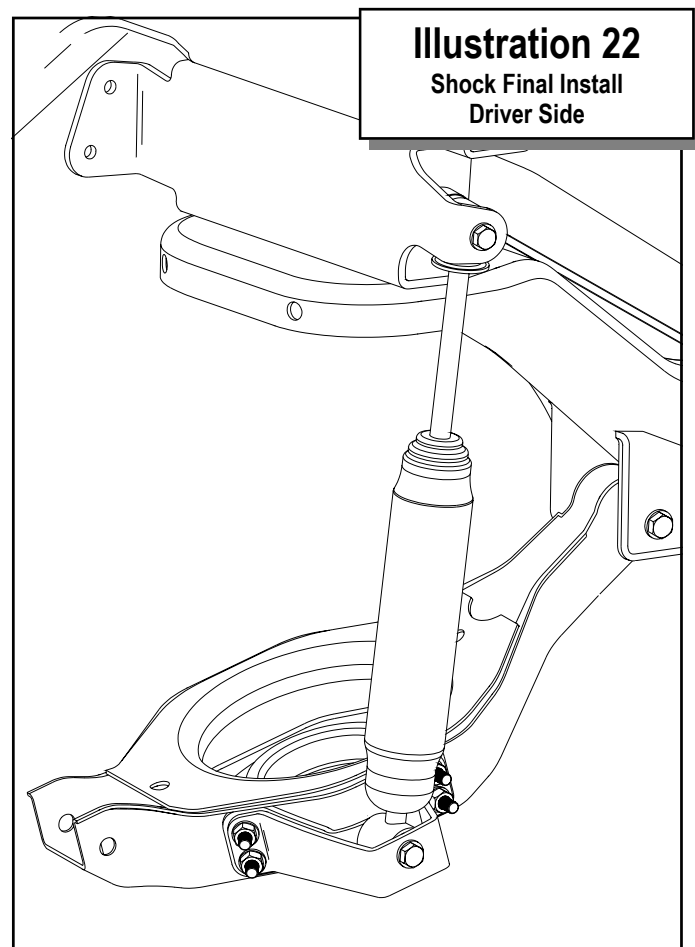

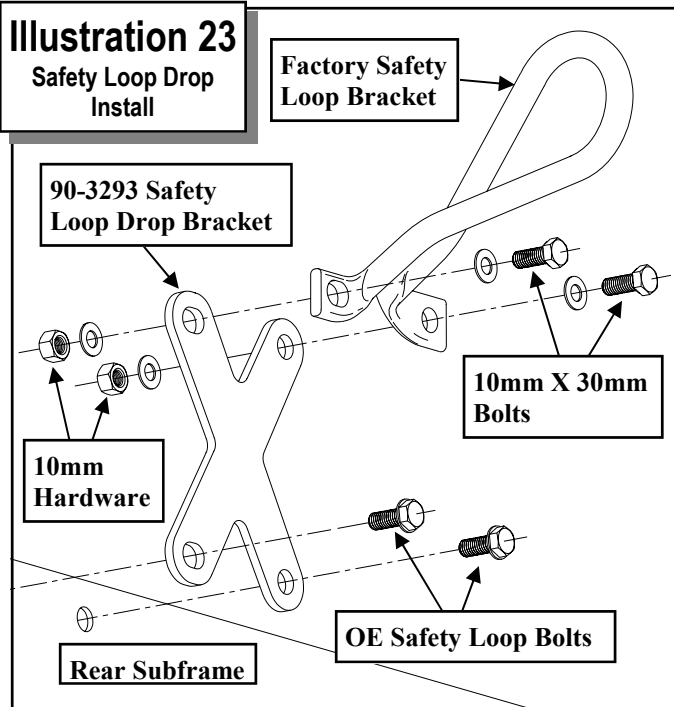

PINCHING PROBLEMS WITH THE BRAKE LINES AND ABS WIRING.

32. Install your new Pro Comp shocks (**MX6112 or 924543 w/ shaft end up**) into the stock location using **OE bolts and 5/8"** washers from pack (**90-6429**) inside the top and bottom mounts. Torque this hardware to 75 ft./lbs.
33. On the driver's side, place the inner lower shock bracket (**90-3265 driver and 90-3263 pass**) against the upper lip of the rear lower control arm with the

curvature facing up. The inner edge of the bracket will be placed **9"** down the control arm from the center of the control arm mounting bolt. Make sure the bracket is firmly pressed up against the upper lip on both sides. Clamp the bracket in place using C-clips. See ILLUSTRATION 19.

34. Using the bracket as a template, center punch the holes for drilling. Remove the bracket and drill the **3/8"** holes (**2** per side) in the rear of the lower rear control arms. See ILLUSTRATION 19.
35. Slip the bolt plate studs (**90-3256**) through the previously drilled holes in the rear lower control arm. See ILLUSTRATION 20.
36. Reinstall the inner lower shock bracket (**90-3263 pass and 90-3265 driver**) with the curvature facing up. Install the outer lower shock bracket (**90-3264 pass and 90-3266 driver**) with the longer leg facing the out toward the tire. See ILLUSTRATION 20.
37. Secure the lower shock brackets to the bolt plates using the supplied **3/8"** hardware.
38. Install the shock sleeves (**54314**) from hardware pack (**90-6071**) into both ends

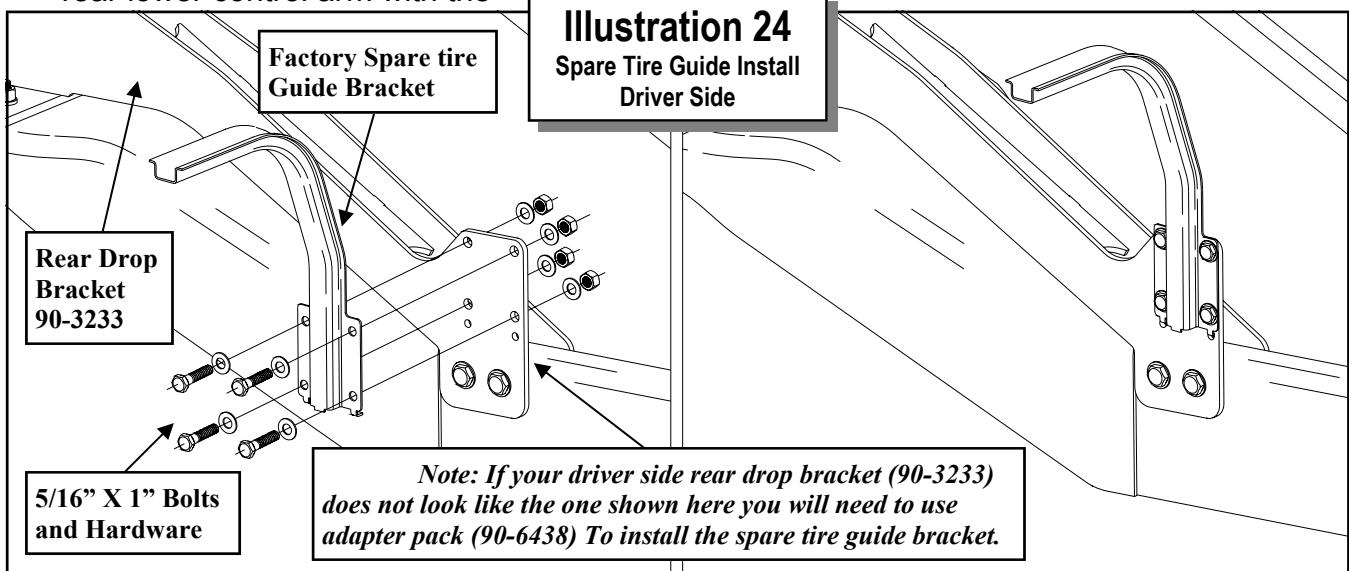

of rear shock **(918509)**.

39. Install the rear shock **(918509 w/ shaft end up)** to the lower bracket assembly using the supplied **1/2" X 3"** bolt and hardware. See ILLUSTRATION 20.
40. Compress the shock and slide it into the rear tab on the rear drop bracket. Secure using the supplied **1/2" X 3 3/4"** bolt, **(90-2524)** spacer (on the inside toward the rear bracket) and hardware. See ILLUSTRATION 21.
41. Repeat on the passenger side.
42. Reconnect the ABS lines.
43. On both sides of the vehicle, check the routing of the brake lines and the ABS wire harnesses. Use the supplied zip ties to secure lines. There must be no pinching, rubbing, or stretching of either component. Use zip ties to secure these items to the steering components.
44. Install the safety loop extension bracket **(90-3293)** to the existing safety loop holes in the rear subframe assembly using the previously removed **OE** bolts. See ILLUSTRATION 23.
45. Reinstall the **OE** safety loop to the safety loop extension bracket using the supplied **10mm X 30mm** bolts and hardware. See ILLUSTRATION 23.
46. Reinstall the wheels and tires and lower the vehicle to the ground. Torque the lug

nuts according to manufacturers specifications.

47. Reinstall the spare tire guide to the driver side rear drop bracket support arm **(90-3233)** and secure with the supplied **5/16" X 1"** bolts and hardware. See ILLUSTRATION 24.

Note: If your driver side rear drop bracket (90-3233) does not look like the one shown in illustration 24 you will need to use adapter pack (90-6438) To install the spare tire guide bracket.

48. Reinstall the spare tire into it's original position. Consult the factory manual for proper reinstallation.
49. Recheck the wheel lug torque on all four wheels at this time.
50. Recheck all hardware for proper installation and torque at this time.

NOTES:

- ⇒ **On completion of the installation, have the suspension and headlights re-aligned.**
- ⇒ **After 100 miles recheck for proper torque on all newly installed hardware.**
- ⇒ **Recheck all hardware for tightness after off road**

NOTICE: FOR 2WD VEHICLES ONLY!

1. Clamp the crossmember support plates (**97-3321 front and rear**) into place on the rear crossmember. See ILLUSTRATION A.

NOTE: Be sure that the top edges of the plates are pressed firmly against the top lip of the crossmember.

2. Using the holes in the support plates (**97-3321**) as guide holes, center punch the rear crossmember for drilling. See ILLUSTRATION B.
3. Scribe a line along the top edge of the crossmember support plates (**97-3321 front and back**) onto the rear crossmember as shown in ILLUSTRATION C.
4. Unclamp and remove the support plates (**97-3321**) from the vehicle.
5. Using a suitable cutting tool, (abrasive cutoff wheel, Sawz-all, etc.) cut the rear crossmember along the previously scribed lines as shown in ILLUSTRATION C.
6. Using a **7/16"** drill bit, drill out the guide marks in the rear crossmember.
NOTE: Do not drill out the outer hole on the driver side rear plate. It is blocked by the fuel tank and is not necessary for this installation.
7. Install and secure the support plates (**97-3321 front and rear**) to the rear crossmember using the **7/16" X 1 1/4"** bolts and hardware. Torque the bolts according to the chart on page 27. See ILLUSTRATION D.
8. It is recommended that the support plates be stitch welded (**1" of weld then skip 1" and then 1" of weld then skip 1" and so on**) to the rear crossmember. Stitch weld along the inside edge of the support plates where they contact the frame. See ILLUSTRATION E.
9. After welding the support plates to the crossmember, clean the area thoroughly and paint the exposed metal with a good quality paint.

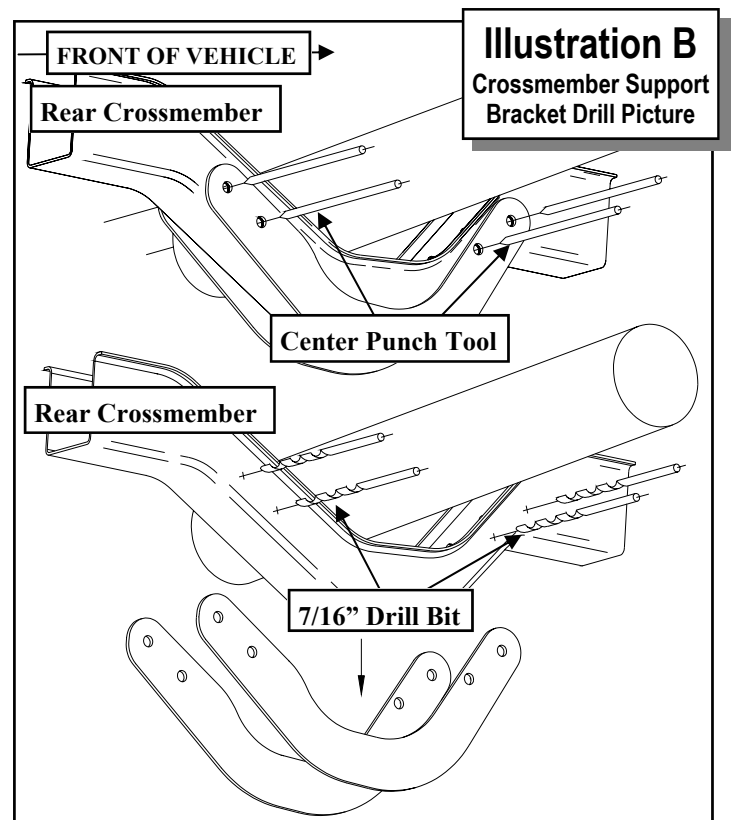
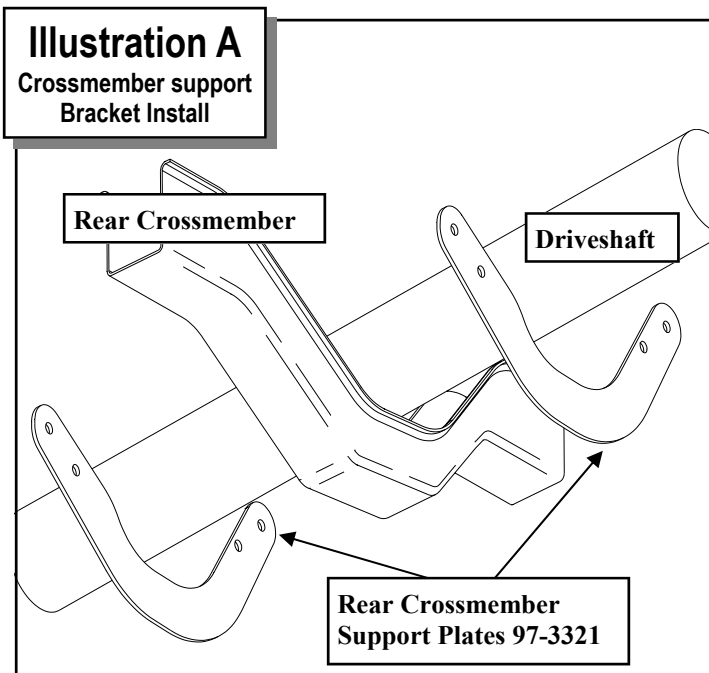
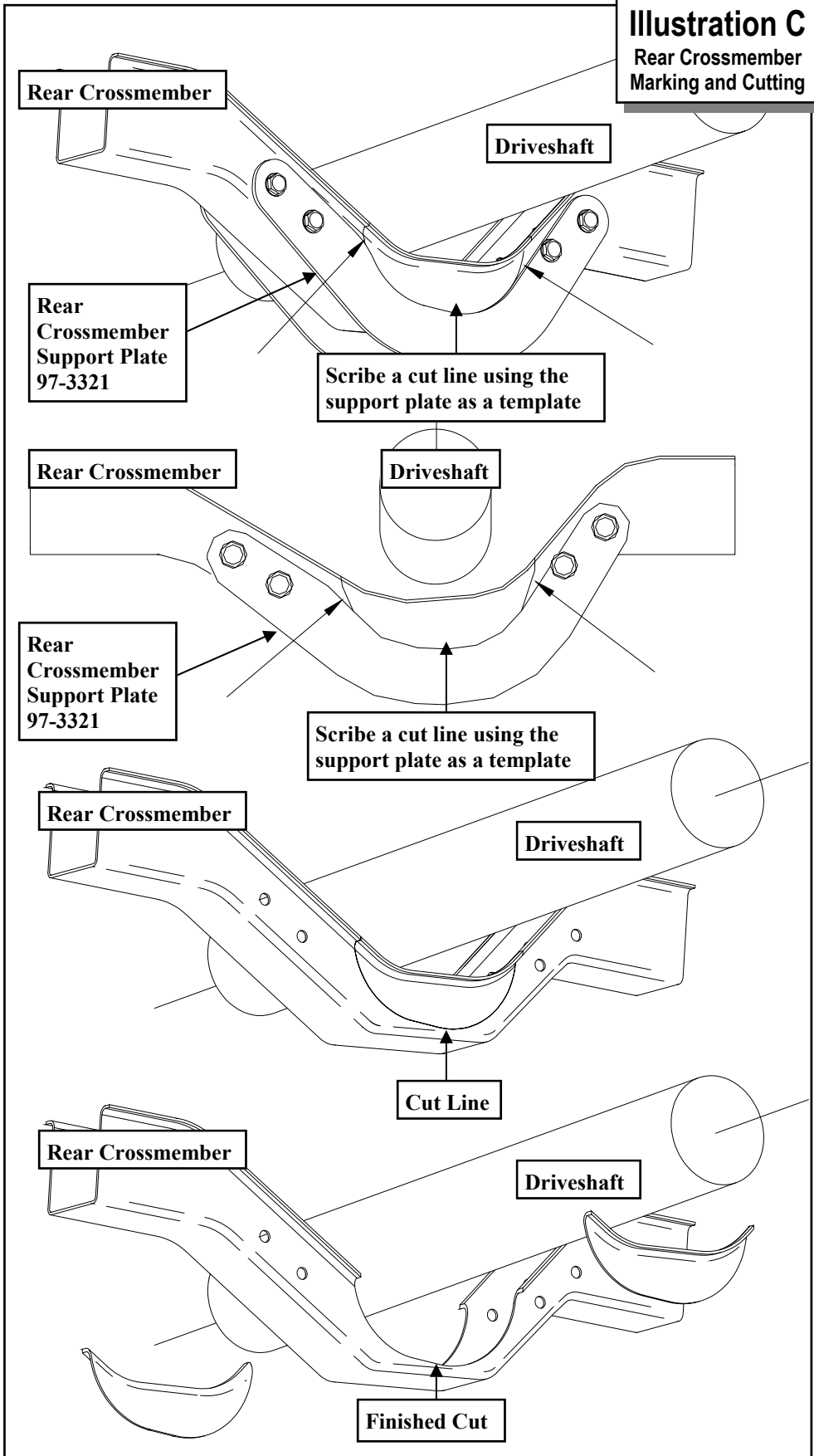
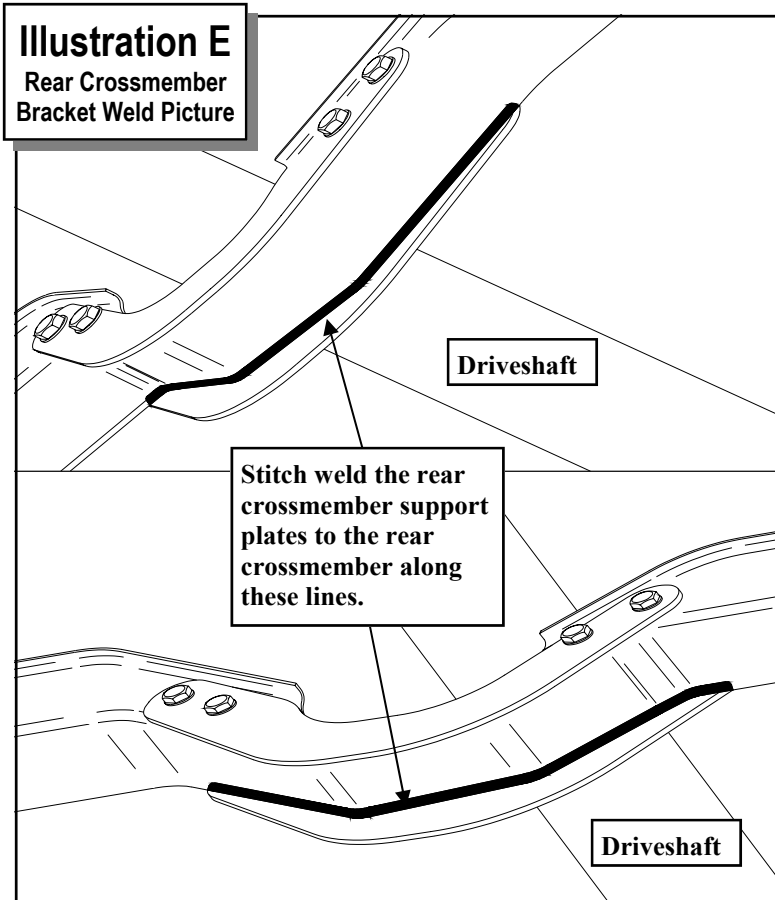
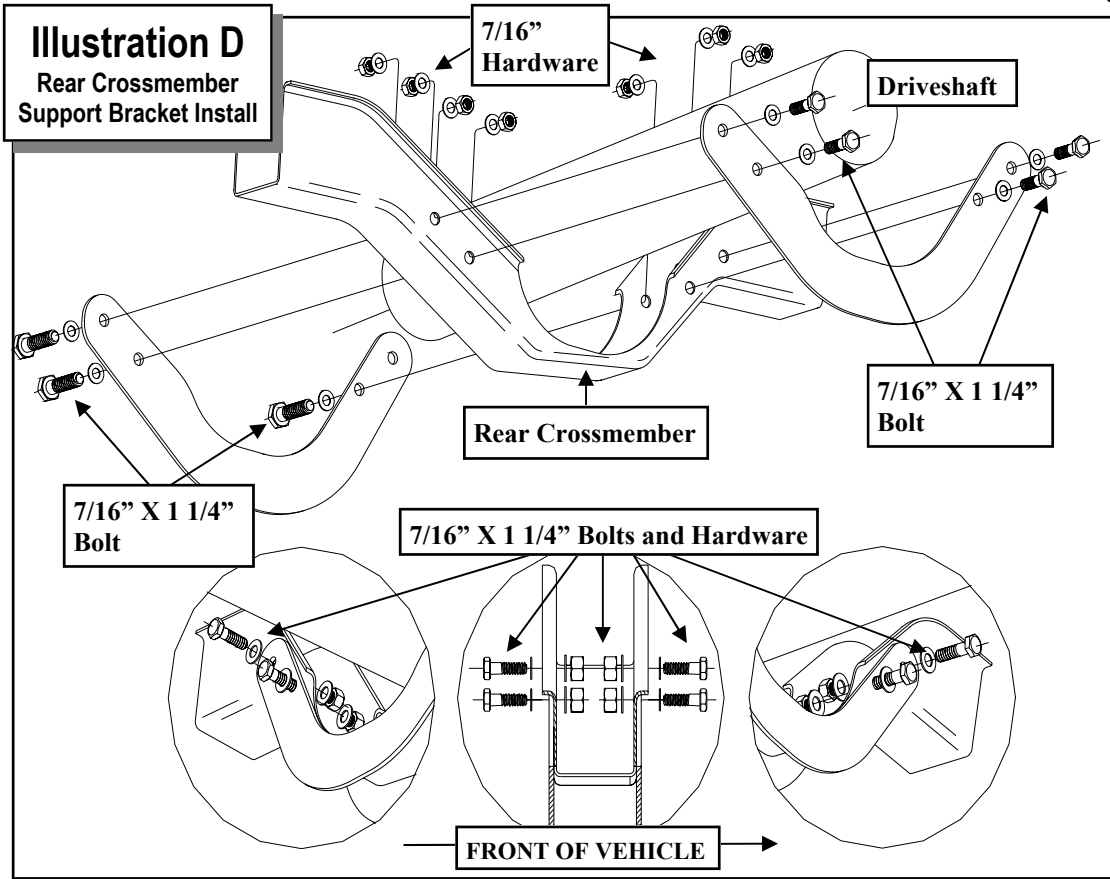

Illustration C
Rear Crossmember
Marking and Cutting





Use this only as a guide for hardware without a called out torque specification in the instruction manual.

| Bolt Torque and ID | | | | | | |
|----------------------------------|---------|---------|----------------------|-----------|------------|------------|
| Decimal System | | | Metric System | | | |
| All Torques in Ft. Lbs. Maximums | | | | | | |
| Bolt Size | Grade 5 | Grade 8 | Bolt Size | Class 9.8 | Class 10.9 | Class 12.9 |
| 5/16 | 15 | 20 | M6 | 5 | 9 | 12 |
| 3/8 | 30 | 45 | M8 | 18 | 23 | 27 |
| 7/16 | 45 | 60 | M10 | 32 | 45 | 50 |
| 1/2 | 65 | 90 | M12 | 55 | 75 | 90 |
| 9/16 | 95 | 130 | M14 | 85 | 120 | 145 |
| 5/8 | 135 | 175 | M16 | 130 | 165 | 210 |
| 3/4 | 185 | 280 | M18 | 170 | 240 | 290 |

1/2-13x1.75 HHCS Grade 5 Grade 8
 (No. of Marks + 2)

D T L X

G = Grade (Bolt Strength)
 D = Nominal Diameter (Inches)
 T = Thread Count (Threads per Inch)
 L = Length (Inches)
 X = Description (Hex Head Cap Screw)

M12-1.25x50 HHCS

D T L X

P = Property Class (Bolt Strength)
 D = Nominal Diameter (Millimeters)
 T = Thread Pitch (Thread Width, mm)
 L = Length (Millimeters)
 X = Description (Hex Head Cap Screw)

Notice to Owner operator, Dealer and Installer:

Vehicles that have been enhanced for off-road performance often have unique handling characteristics due to the higher center of gravity and larger tires. This vehicle may handle, react and stop differently than many passenger cars or unmodified vehicles, both on and off-road. You must drive your vehicle safely! Extreme care should always be taken to prevent vehicle rollover or loss of control, which can result in serious injury or even death. Always avoid sudden sharp turns or abrupt maneuvers and allow more time and distance for braking! Pro Comp reminds you to fasten your seat belts at all times and reduce speed! We will gladly answer any questions concerning the design, function, maintenance and correct use of our products.

Please make sure your Dealer/Installer explains and delivers all warning notices, warranty forms and instruction sheets included with Pro Comp product.

Application listings in this catalog have been carefully fit checked for each model and year denoted. However, Pro Comp reserves the right to update as necessary, without notice, and will not be held responsible for misprints, changes or variations made by vehicle manufacturers. Please call when in question regarding new model year, vehicles not listed by specific body or chassis styles or vehicles not originally distributed in the USA.

Please note that certain mechanical aspects of any suspension lift product may accelerate ordinary wear of original equipment components. Further, installation of certain Pro Comp products may void the vehicle's factory warranty as it pertains to certain covered parts; it is the consumer's responsibility to check with their local dealer for warranty coverage before installation of the lift.

Warranty and Return policy:

Pro Comp warrants its full line of products to be free from defects in workmanship and materials. Pro Comp's obligation under this warranty is limited to repair or replacement, at Pro Comp's option, of the defective product. Any and all costs of removal, installation, freight or incidental or consequential damages are expressly excluded from this warranty. Pro Comp is not responsible for damages and / or warranty of other vehicle parts related or non-related to the installation of Pro Comp product. A consumer who makes the decision to modify his vehicle with aftermarket components of any kind will assume all risk and responsibility for potential damages incurred as a result of their chosen modifications. Warranty coverage does not include consumer opinions regarding ride comfort, fitment and design. Warranty claims can be made directly with Pro Comp or at any factory authorized Pro Comp dealer.

IMPORTANT! To validate the warranty on this purchase please be sure to mail in the warranty card.

Claims not covered under warranty-

- Parts subject to normal wear, this includes bushings, bump stops, ball joints, tie rod ends and heim joints
 - Discontinued products at Pro Comp's discretion
- Bent or dented product
- Finish after 90 days
- Leaf or coil springs used without proper bump stops
- Light bulbs
- Products with evident damage caused by abrasion or contact with other items
- Damage caused as a result of not following recommendations or requirements called out in the installation manuals
- Products used in applications other than listed in Pro Comp's catalog
- Components or accessories used in conjunction with other manufacturer's systems
- Tire & Wheel Warranty as per Pro Competition Tire Company policy
- Warranty claims without "Proof of Purchase"
- Pro Comp Pro Runner coil over shocks are considered a serviceable shock with a one-year warranty against leakage only. Rebuild service and replacement parts will be available and sold separately by Pro Comp. Contact Pro Comp for specific service charges.
- Pro Comp accepts no responsibility for any altered product, improper installation, lack of or improper maintenance, or improper use of our products.

E-Mail: tech@explorerprocomp.com
Website: www.explorerprocomp.com
Fax: (619) 216-1474
Ph: (619) 216-1444

| |
|---|
| PLACE WARRANTY REGISTRATION NUMBER HERE: _____ |
|---|