



**1136 1988-1998
CHEVROLET / GMC
4WD 1/2 TON PICKUP
(6 LUG) 6" IFS
NON-AUTO TRAC**

This document contains very important information that includes warranty information and instructions for resolving problems you may encounter. Please keep it in the vehicle as a permanent record.

Part #	Description	Qty.	Illus.	Page
BOX 1 OF 4 PN 1136-1				
90-1799	REAR CROSS MEMBER	1	10,12,13	12,14
90-2126	LATERAL COMP STRUT-(Not Included- Available as an Option)	2	13,14	14,15
90-2354	STEERING DROP/CENTER LINK	1	8	10
90-6286	HARDWARE PACK: BUSHINGS/ SLEEVES	1	-	-
15-11018	BUMP STOP - LOW PROFILE - HEX	2	10	12
15-11031	CONE BUMP STOP - SHORT SHAFT	2	10	12
15-11148	BUSHING - DIFFERENTIAL MOUNT/COMP STRUT	12	7	9
90-2108	SLEEVE-GM (PASS.) DIFF DROP	2	7	9
90-2109	SLEEVE-GM COMPRESSION STRUT	4	13,14	14,15
90-2110	SLEEVE-GM COMPRESSION STRUT - (not used)	2	-	-
73-03700030	3/8" SAE GR. 8 WASHER -	4	10	12
72-03700100512	3/8" USS GR. 5 NYLOC NUT	4	10	12

BOX 2 OF 4 PN 1136-2

90-1807	FRONT CROSS MEMBER	1	8,9,12	10,11,14
90-1261	(PASS.) DIFF. DROP BRACKET	1	7	9
90-3012	(DRIVER.) DIFF. DROP BRACKET	1	6	9
90-2124	TORQUE TUBE	1	6	9
13-90347	U-BOLT, SQUARE 5/8"-18	4	16,17	17,18
95-550	5 1/2" LIFT BLOCK	2	16,17	17,18
20-65471	HARDWARE PACK: U-BOLTS	1	-	-
13-10488	HIGH NUT, 5/8"	8	16,17	17,18
13-30369	FLAT WASHER, 5/8"	8	16,17	17,18

Optional Equipment Available from your **Pro Comp** Distributor!

TRACTION BARS:	71000
TRAC BAR MOUNTING KIT:	71182, 71082(SHORT BED)
SKID PLATE:	51196 (KIT)
LIGHT BAR: (HOOP)	21400 (BLACK), 21400G (GREY)
LIGHT BAR: (PRO RUNNER)	14000 (BLACK), 14000G (GREY)
STEERING STABILIZER:	217513

Also, check out our outstanding selection of **Pro Comp** tires to compliment your new installation!

BOX 3 OF 4 PN 1136-3

Part #	Description	Qty.	Illus	Page
90-6083	HARDWARE PACK: A-ARM DROPS	1	-	-
90-2111	SLEEVE W/ WASHER	2	11	13
90-2112	SLEEVE-.750"X.50"X3.94"	2	11	13
90-2113	SLEEVE-.750"X.50"X3.44"	2	11	13
90-1215	LOAD WASHER-FLAT SIDE-2.0" O.D.X.550" ID.	6	11	13
90-1216	LOAD WASHER-1.50" O.D. X .532" I.D.	2	11	13
90-6080	HARDWARE PACK: TORSION DROP	1	-	-
70-0375001500	3/8" X 5" USS GR. 5 HEX BOLT	2	15	16
70-0504001500	1/2" X 4" USS GR. 5 HEX BOLT	4	15	16
72-03700100512	3/8" USS NYLOC NUT	2	15	16
72-05000100512	1/2" USS NYLOC NUT	4	15	16
73-03700030	3/8" SAE FLAT WASHER	4	15	16
73-05000030	1/2" SAE FLAT WASHER	8	15	16
90-6078	HARDWARE PACK: A-ARM DROPS	1	-	-
70-0505501500	1/2" X 5 1/2" USS GR.. 5 HEX BOLT	6	11	13
72-05000100512	1/2" USS NYLOC NUT	6	11	13
73-05000030	1/2" SAE FLAT WASHER	12	11	13
96-1313	DIFF. MOUNT COVER PLATE	1	4,5	8
90-6084	HARDWARE PACK: BRAKE LINE	1	-	-
7225 AB	BRAKE LINE-FRONT GM IFS W/CRUSH WASHER	2	-	-
90-6029	HARDWARE PACK-BRAKE LINE SUPPORT KIT	1	-	-
90-6085	HARDWARE PACK CONTAINING: SHOCK FLIP	1	-	-
45558	STRAIGHT 5/8" BLACK BUSHING	4	-	-
600040-1	CUT 5/8" BLACK "T" BUSHING	4	-	-
90-1155	UPPER A-ARM DROP BRACKET (DRIVER.)	1	11	13
90-1162	UPPER A-ARM DROP BRACKET (PASS.)	1	-	-
90-1104	STRUT MOUNT -(Not Included- Available as an Option)	2	14	15
90-6079	HARDWARE PACK: (Not Included- Available as an Option)	1	-	-
73-05000030	1/2" SAE FLAT WASHER	12	13,14	14,15
72-05000100512	1/2" USS NYLOC NUT	6	13,14	14,15
70-0503001500	1/2" X 3" USS GR.5 HEX BOLT - (not used)	2	-	-
70-0504001500	1/2" X 4" USS GR.5 HEX BOLT	4	13,14	14,15
90-4124	TORSION BAR DROP	2	15	16
90-6077	HARDWARE PACK: DIFF DROP	1	-	-
70-0431251500	7/16" X 1 1/4" USS GR.5 HEX BOLT	1	6	9
70-0564001500	9/16" X 4" USS GR.5 HEX BOLT	1	6	9
72-043100512	7/16" USS NYLOC NUT	1	6	9
72-056100512	9/16" USS NYLOC NUT	1	6	9
73-04300030	7/16" SAE FLAT WASHER	2	6	9
73-05600030	9/16" SAE FLAT WASHER	2	6	9

Part #	Description	Qty.	Illus.	Page
90-6282	HARDWARE PACK: CENTER LINK DROP	1	-	-
90-2055	1/2" ID X 1 1/2" OD X 3/8" SPACER	2	8	10
90-2014	SPACER, 3/4" OD X 1/2" ID X 1/4"	4	8	10
90-4053	STEERING LINK	2	8	10
90-4036	STEERING CONE REDUCER	4	8	10
90-1820	CAM BLOCK OFF PLATES	8	11	13
90-2394	CENTER LINK SPACER- (Steering Stabilizer)	2		
90-6309	HARDWARE PACK: CENTER LINK DROP	1	-	-
70-0372501800	3/8" X 2.5" GR. 8 HEX BOLT- (Steering Stabilizer)	2	-	-
72-03700100512	3/8" USS NYLOC NUT- (Steering Stabilizer)	2	-	-
73-03700030	3/8" SAE FLAT WASHER - (Steering Stabilizer)	4	-	-
70-0504001800	1/2" X 4" GR. 8 HEX BOLT	2	8	10
72-05000100512	1/2" USS NYLOC NUT	2	8	10
73-05000030	1/2" SAE FLAT WASHER	4	8	10
73-05000838	1/2" AN FLAT WASHER - (not used)	2	-	-
90-6283	HARDWARE PACK: STEERING LINK	1	-	-
73-05000030	1/2" SAE FLAT WASHER	4	8	10
72-05000100512	1/2" USS NYLOC NUT	2	8	10
70-0502751800	1/2" X 2 3/4" GR. 8 HEX BOLT	2	8	10
90-6284	HARDWARE PACK: CROSSMEMBERS	1	-	-
70-0624501800	5/8" X 4 1/2" USS GR. 8 HEX BOLT	2	12	14
70-0625501800	5/8" X 5 1/2" USS GR. 8 HEX BOLT	2	12	14
72-06200100512	5/8" USS NYLOC NUT	4	12	14
73-06200030	5/8" SAE FLAT WASHER	8	12	14
90-6302	HARDWARE PACK: CAM BLOCK OFF PLATE	1	-	-
70-0564001800	9/16"-12 X 4" GR. 8	4	11	13
73-05600832	9/16" SAE FLAT WASHER	8	11	13
72-056100816	9/16" USS STOVER NUTS	4	11	13
90-6277	HARDWARE PACK -(Not Included- Available as an Option)	1	-	-
90-1582	1/2" NUT PLATE	2	14	15
70-0501001500	1/2" X 1 1/2" HEX BOLT USS GR 5	2	14	15
72-050001000512	1/2" USS NYLOCK NUT GR. 5	2	14	15
73-05000032	1/2" USS FLAT WASHER GR. 5	4	14	15

BOX 4 OF 4 PN 1136-4

324501	ES3000 FRONT SHOCK ABSORBERS	2	-	-
329500	ES3000 REAR SHOCK ABSORBERS	2	-	-

Introduction:

- ◆ This installation requires a professional mechanic!
- ◆ We recommend that you have access to a factory service manual for your vehicle to assist in the disassembly and reassembly of your vehicle. It contains a wealth of detailed information.
- ◆ Ensure that your work space is of adequate size and the work surface is level. Place the vehicle in neutral. Place your floor jack under the front cross member and raise vehicle. Place jack stands under the frame rails behind the front wheel wells and lower the frame onto the stands. Remove the jack and place the vehicle back in gear, set the emergency brake, and place blocks both in front and behind the rear wheels.
- ◆ Prior to installation, carefully inspect the vehicle's steering and driveline systems paying close attention to the tie rod ends, ball joints, wheel bearing preload, pitman and idler arm. Additionally, check steering-to-frame and suspension-to-frame attaching points for stress cracks. The overall vehicle must be in excellent working condition. Repair or replace all worn or damaged parts!
- ◆ Read the instructions carefully and study the illustrations before attempting installation! You may save yourself a lot of extra work.
- ◆ Check the parts and hardware against the parts list to assure that your kit is complete. Separating parts according to the areas where they will be used and placing the hardware with the brackets before you begin will save installation time.
- ◆ Check the special equipment list and ensure the availability of these tools.
- ◆ Secure and properly block vehicle prior to beginning installation.
- ◆ ***ALWAYS*** wear safety glasses when using power tools or working under the vehicle!
- ◆ Use caution when cutting is required under the vehicle. The factory undercoating is flammable. Take appropriate precautions. Have a fire extinguisher close at hand.
- ◆ Foot pound torque readings are listed on the Torque Specifications chart at the end of the instructions. These are to be used unless specifically directed otherwise. Apply thread lock retaining compound where specified.
- ◆ ***Please note that while every effort is made to ensure that the installation of your Genuine Truck Accessories lift kit is a positive experience, variations in construction and assembly in the vehicle manufacturing process will virtually ensure that some parts may seem difficult to install. Additionally, the current trend in manufacturing of vehicles results in a frame that is highly flexible and may shift slightly on disassembly prior to installation. The use of pry bars and tapered punches for alignment is considered normal and usually does not indicate a faulty product. However, if you are uncertain about some aspect of the installation process, please feel free to call our tech support department at the number listed on the cover page. We do not recommend that you modify the Genuine Truck Accessories parts in any way as this will void any warranty expressed or implied by the Genuine Truck Accessories company.***
- ◆ This instruction packet contains valuable warranty information and should be kept in the vehicle as a permanent record.
- ◆ If you are up grading from an existing Genuine Truck Accessories kit you will need to get a new factory center link from the dealer. It is install with the nut of the tie rod end to the front of the vehicle. As it was installed from the factory.

Special Equipment

A special removal tool is required for safe removal and installation of the torsion adjuster arms. This special puller can be purchased from your local GM dealer (Tool #J36202) or from Kent Moore Tool Group in Roseville, MI. (800) 345-2233 or (313) 774-9500 (Part #J22517-C). You may be able to rent one of these at your local parts store. Please refer to your GM service manual for more information.

WARNING:

Be extremely careful when loading or unloading the torsion bars! There is a tremendous amount of stored energy in the bars. Keep your hands and body clear of the adjuster arm assembly and puller tool in case anything slips or breaks! Remember your safety glasses!

This kit requires a minor amount of welding. Make sure you have access to a welder and someone qualified to do the welding.

Please Note:

- ◆ Front end and headlight realignment is necessary.
- ◆ Exhaust modifications may be necessary. Genuine Truck Accessories kit 51088-20 can be used on some models.
- ◆ Speedometer and ABS recalibration will be necessary if larger tires (10% more than stock diameter) are installed
- ◆ This suspension system utilizes the stock torsion bars which normally afford the best ride quality. If, after kit is installed, ride or handling seems too “soft”, heavier Gross Vehicle Weight Rating (GVWR) bars can be installed. GM offers various bars for up to 10,000 lbs. GVWR.
- ◆ **Due to differences in manufacturing, dimensions and inflated measurements, tire and wheel combinations should be test fit prior to installation.** Tire and wheel choice is crucial in assuring proper fit, performance, and the safety of your Genuine Truck Accessories equipped vehicle. For this application, a wheel not to exceed 9” in width with a minimum backspacing of 3.25” must be used. Additionally, a quality tire of radial design, not exceeding 35” tall X 12.5” wide is recommended. Please note that the use of a 35” X 12.5” tire may require fender modification. Violation of these recommendations will not be endorsed as acceptable by Genuine Truck Accessories and will void any and all warranties either written or implied.

NOTICE TO INSTALLER AND OPERATOR

Front end noise and vibration may occur on '94-'95 vehicles equipped with new downsized Spicer type u-joint front drive shafts and operated in 4wd on even surfaces such as pavement. It is recommended not to exceed 20 mph in these conditions or replacement to a C.V. style (early model) front driveshaft may be required.

FRONT DISASSEMBLY:

1. Measure and record the distance from the center of each wheel to the top of its fender opening. Record below.

LF: _____ RF: _____

LR: _____ RR: _____

2. Ensure that your work space is of adequate size and the work surface is level. Place the vehicle in neutral. Place your floor jack under the front cross member and raise vehicle. Place jack stands under the frame rails behind the front wheel wells and lower the frame onto the stands (*It is important to have the vehicle sitting level side-to-side on jack stands before starting this project*). Remove the jack and place the vehicle back in gear, set the emergency brake, and place blocks both in front and behind the rear wheels.
3. Remove front wheels.
4. Remove any skid plates or debris shields from the vehicle.
5. Measure the torsion bar adjusting screw depth and record this dimension for later use on re-assembly. See ILLUSTRATION 1.

LEFT: _____ RIGHT: _____

WARNING! Be extremely careful when unloading or loading the torsion bars on your vehicle. There is a tremendous amount of stored energy! Keep your hands and body clear of the adjuster arm assembly and puller tool in case anything slips or breaks!

6. Mark the torsion bar orientation for later re-installation. Apply a small amount of lubrication grease to the puller threads and the puller shaft-to-adjuster arm contact point. Load

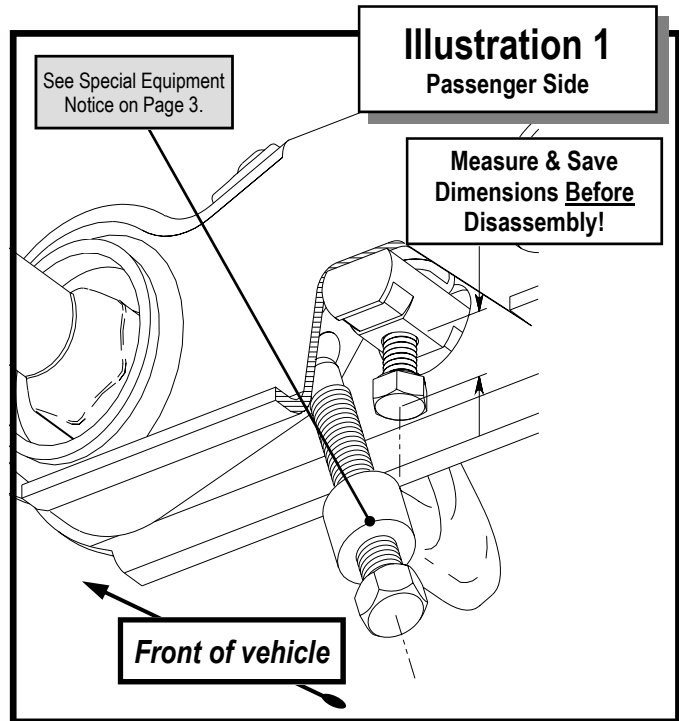

the puller and torsion adjuster arm until the adjuster nut can be removed from the cross member. Remove the torsion bar adjusting screw. Release the puller to unload the torsion bar. With the bar unloaded, slide it forward into the lower control arm until the adjuster arm falls free.

NOTE: If the bar seems stuck, use a hammer and punch through the hole in the rear of the cross member to dislodge it.

7. Repeat this procedure on the other side of the vehicle.

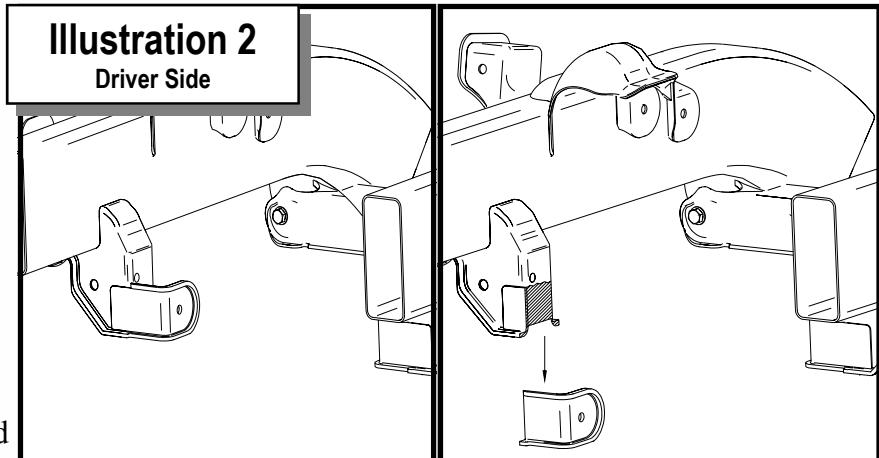

8. Remove the torsion bars from the lower A-arms.
9. Remove the torsion bar cross member by unbolting it from the frame.
10. If you have a steering damper mounted, remove it from the vehicle.
11. Remove the front shock absorbers.
12. Remove the nut from the OE tie rod end. Using an appropriate removal tool, remove the tie rod end from the spindle.
13. Remove the brake calipers from the rotor and secure them clear of the work area. Secure calipers up with wire so they do not hang.

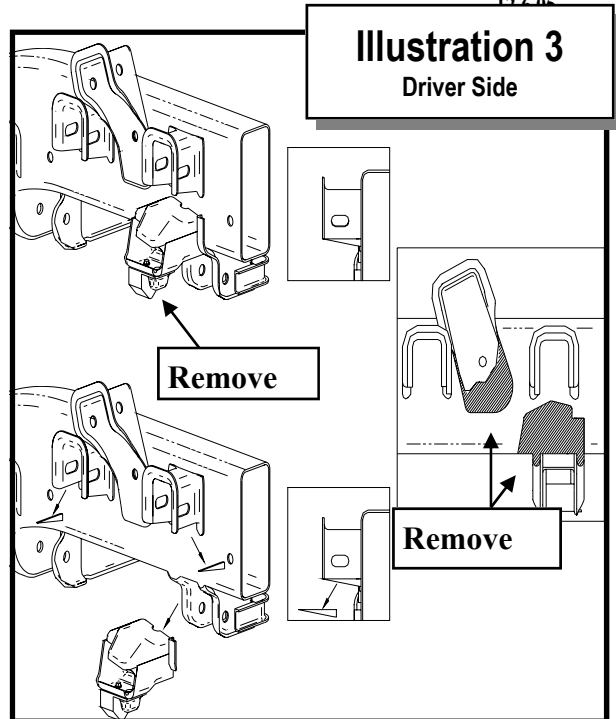

STEPS 14 THROUGH 18 ARE PERFORMED ONE SIDE AT A TIME:

14. At driver side front, locate the rubber brake hose that runs from caliper to frame. Pinch it closed with vise grips or a small "C" clamp and detach it from the caliper. Plug or cover the caliper opening to prevent contamination.

NOTE: *If your vehicle is equipped with an Anti-Lock Brake System, disconnect the sensor wire at plug and reposition so not to damage ends.*

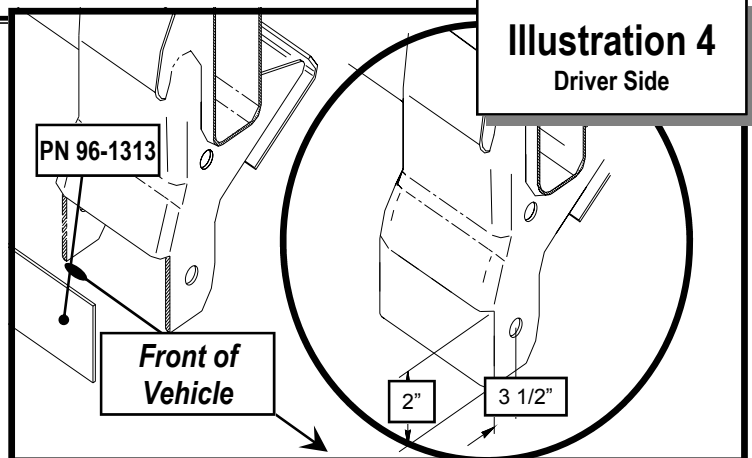

15. Remove the 6 bolts that attach CV axle to the differential.
16. Detach inner end of tie rod from relay rod/center link.
17. Remove both anti-sway bar end links, which connect bar body to lower control arms. The link nuts, accessed through the bottom of the arms, are somewhat restricted. It may be necessary to detach the bar at the frame.
18. Place a floor jack under the hub assembly. Remove upper and lower control arm bolts and lower assembly to floor.

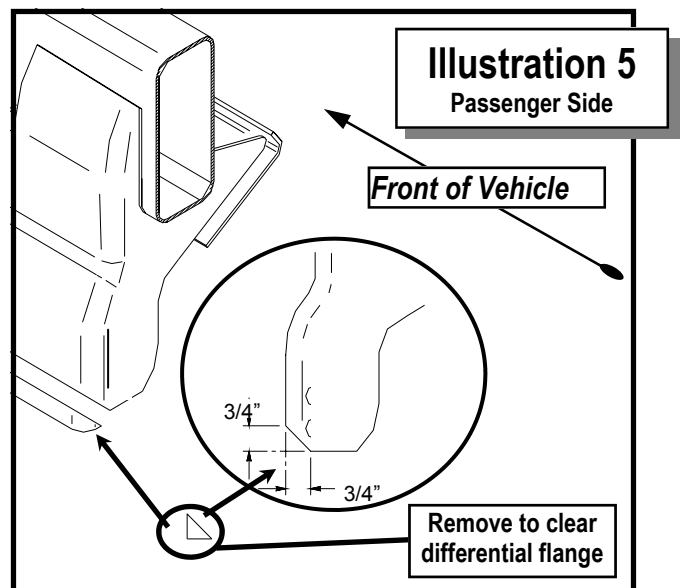

Repeat steps 14 through 18 on the remaining side of the vehicle:

19. Detach the drive shaft at the differential and secure it out of the way.
20. If vehicle has a differential skid plate, remove it at this time.
21. Unplug the differential's electronic coupler and vent hose.
22. Remove the bolt that attached the rear of the differential to lower control arm/differential mount. Using a hack saw or suitable cutting tool, cut off the driver side rear wrap around differential bracket as shown in ILLUSTRATION 2. This allows differential to drop straight down. See ILLUSTRATION 2 for additional information.

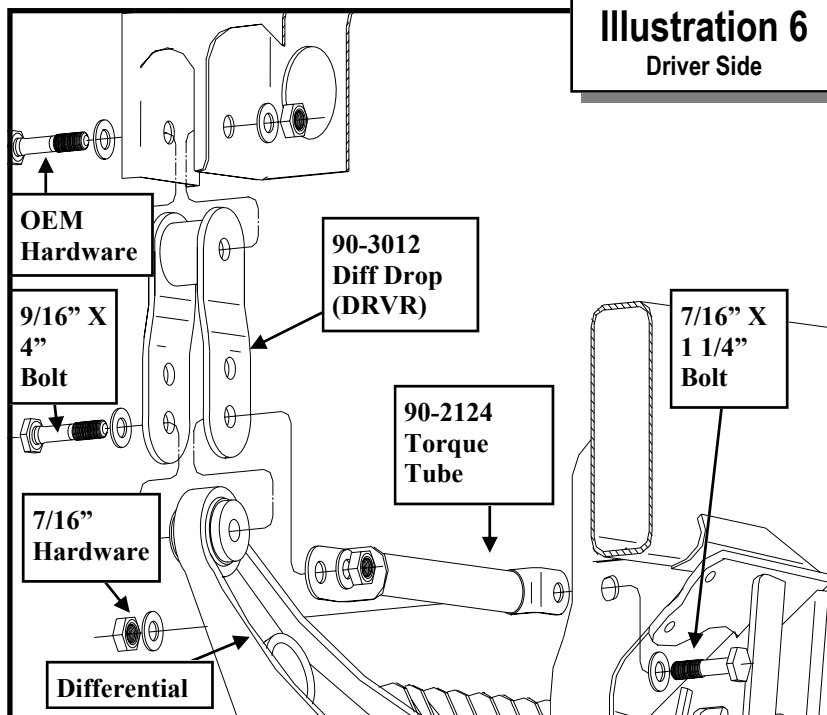

Illustration 6
Driver Side

23. Position a floor jack under the differential and remove the 3 remaining bolts:
 - 1 bolt - driver side differential to crossmember
 - 2 bolts - passenger side axle tube to frame
24. Now lower the assembly to the floor.
25. On both sides of the frame near the upper rear control arm mounts, unbolt the stock rubber up travel compression stops from their steel frame mount brackets and discard. With a torch, or reciprocating saw carefully trim the steel frame mount brackets from the frame as shown in ILLUSTRATION 3.
26. **CAUTION: UNDERCOATING IS FLAMMABLE.** Grind clean all cutting slag from the trimming performed in previous steps. Paint and undercoat exposed metal.
27. Detach the relay rod/ center link

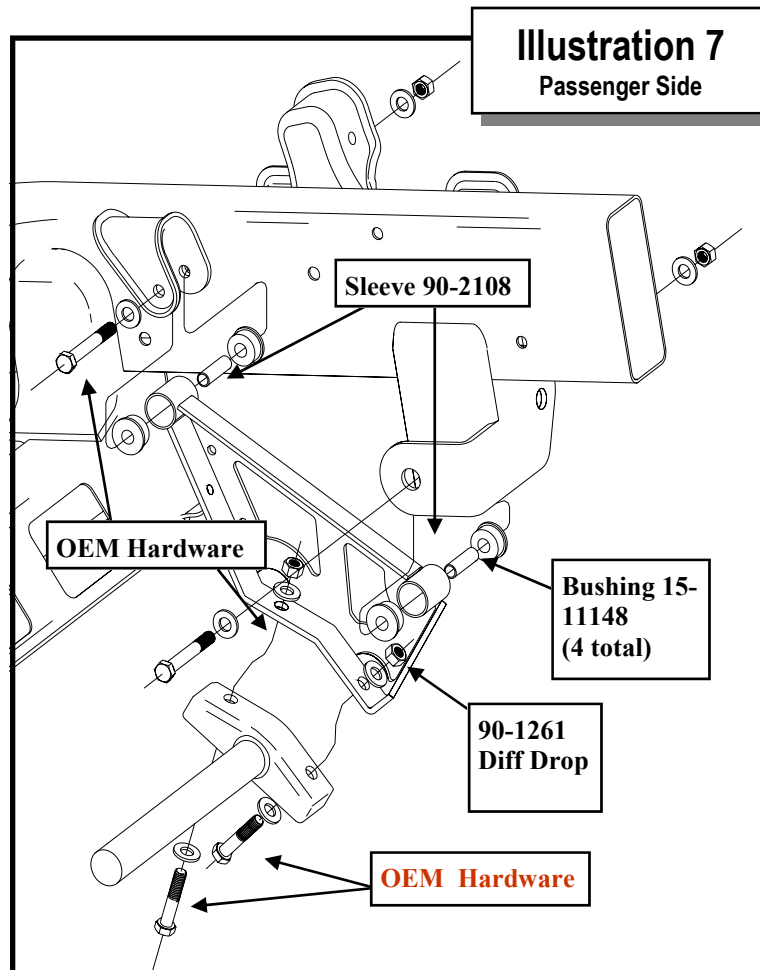

Illustration 7
Passenger Side

from the pitman and idler arm studs.

28. Detach the anti-sway bar mounts from the frame. Re-install, sway bar flipped over from the original position.
29. On the driver side lower A-arm pocket, carefully cut the rear section out using the weld in plate (PN 96-1313) and ILLUSTRATION 4 & 5 as a guide.

FRONT INSTALLATION:

1. Tack the weld in plate (PN 96-1313) to the back of the pocket. **DO NOT** finish welding until the front differential has been reinstalled to ensure there is adequate clearance between the differential and the frame. See ILLUSTRATION 4 & 5.
2. Loosely install the driver side differential drop (PN 90-3012) into the OEM location with the OEM nut and bolt. ILLUSTRATION 6.
3. Assemble pass side differential drop (PN 90-1261) using bushings and sleeves (PN 15-11148

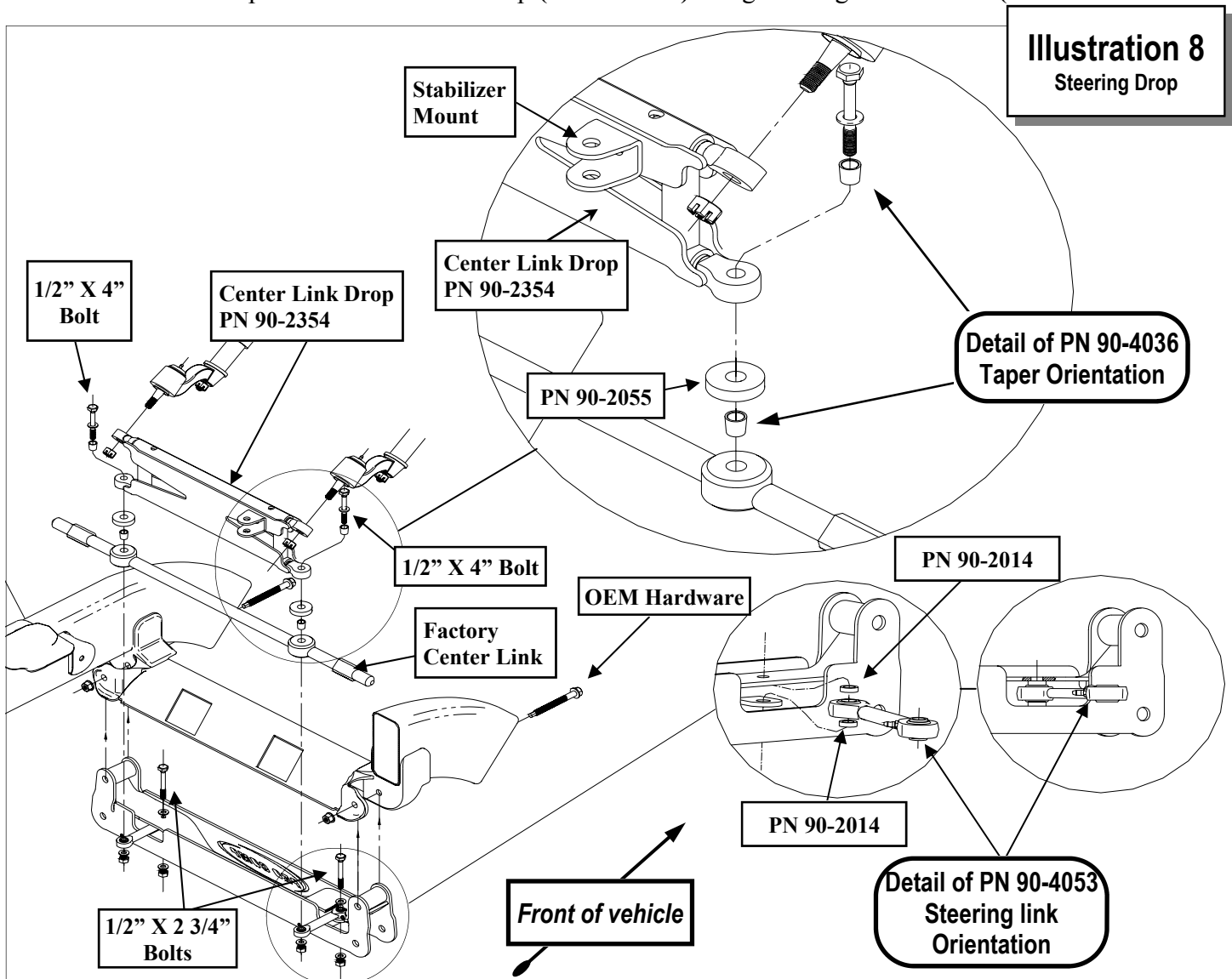

and PN 90-2108) install using the OEM nuts and washers, install the passenger side differential drop to the OEM mount as shown in ILLUSTRATION 7.

4. Hang the differential from the drivers side drop (PN 90- 3012) using the supplied 9/16" X 4" bolt. Install the supplied torque strut (PN 90-2124) to diff. drop using 9/16" hardware as shown in ILLUSTRATION 6. Install the supplied washer and lock nut and tighten the assembly enough so that the strut can be moved without much effort to complete step 10.
5. Attach the differential to the passenger side diff drop bracket (PN 90-1261) as shown in ILLUSTRATION 7 with the OEM nuts and bolts. At this point, leave the fasteners slightly loose until the torque strut is positioned and the main cross member is back in place. **Please note: On some models a small amount of material will have to be removed from the frame around the passenger drop for adequate clearance. Maintain a minimum of 1/4" clearance around this flange. SEE ILLUSTRATION 5.**
6. Install the rear cross member (PN 90-1799) into the truck using the OEM bolts with heads facing rearward to hold it in place. Carefully guide the differential mounting bushing into the mounting flange on the new cross member. See ILLUSTRATION 10
7. Install the OEM bolt through the rear cross member and differential bushing with the threads to the inside of the truck and install the OEM nut. Snug all differential mounting hardware to secure the differential location at this time.

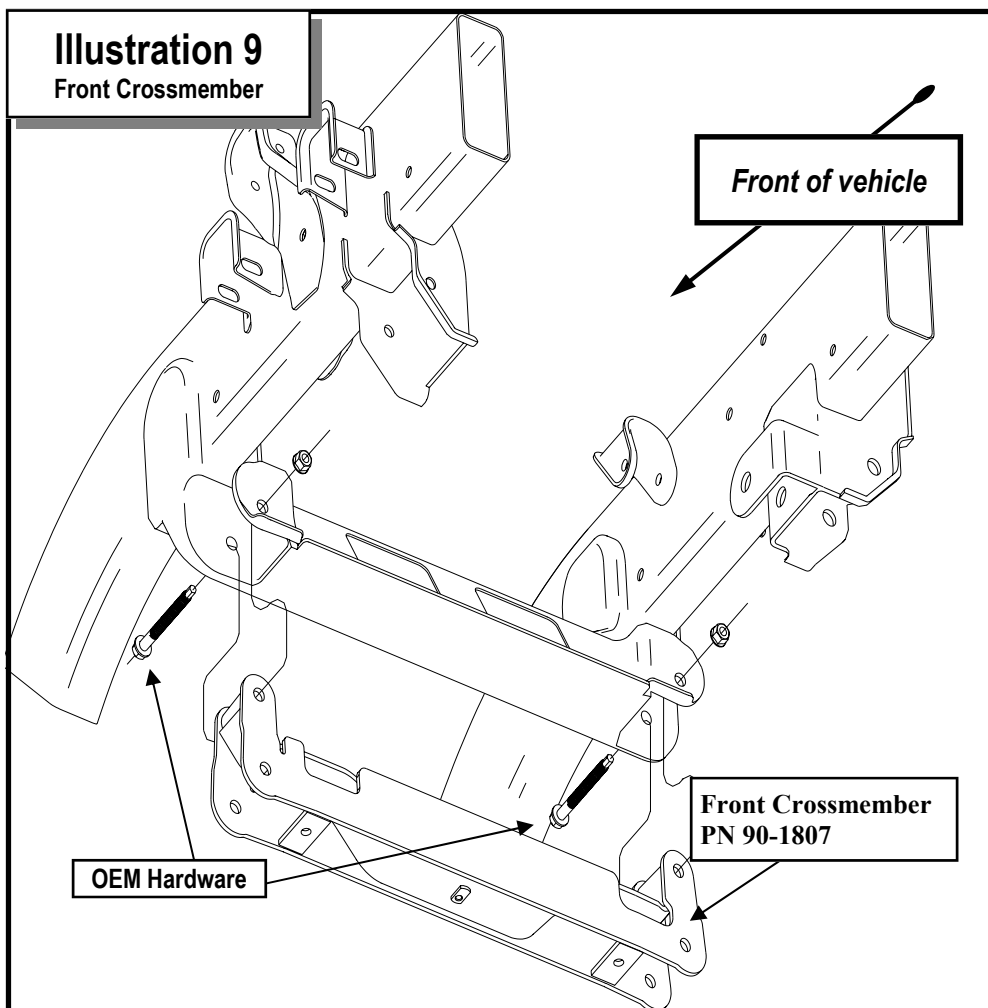

NOTE: It is very important that the differential is centered in the chassis. The best way to accomplish this is to measure the distance from the C.V. flange on the differential to the rear lower control arm mounting hole. Compare driver side to passenger side and move differential to center. On some models the cast ribs on the differential case will need to be ground away to provide adequate clearance between differential case and the factory lower control arm pocket.

⇒ Failure to center the differential may cause premature constant velocity (C.V.) joint wear or failure.

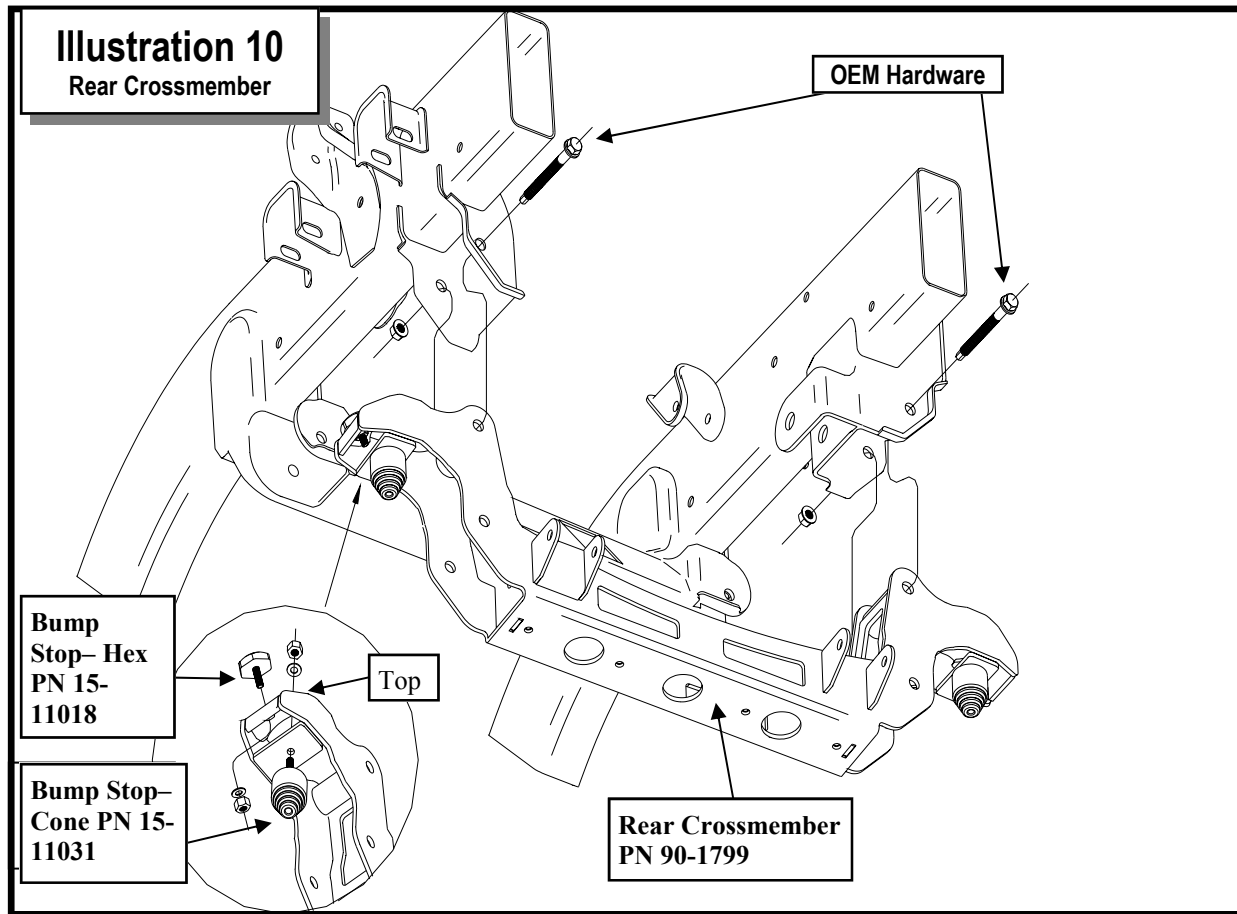

8. Check clearance between the differential and the weld in plate. If needed, remove more material until adequate clearance is achieved. See ILLUSTRATION 8.
9. Finish welding the weld in plate (PN 96-1313). Paint the welded areas to prevent rust.
10. Rotate the torque strut into place and install the supplied 7/16" X 1 1/4" bolt through the strut and hole in the frame member. Leave all hardware loose until the completion of the rear crossmember installation.
11. Install bump stops (PN 15-11018) and (PN 15-11031) onto Rear Crossmember (PN 90-1799) as shown in ILLUSTRATION 10.
12. Reinstall the rear cross member. Torque all differential and cross member hardware to specifications.
13. With the front cross member on a workbench, assemble the steering link assemblies (PN 90-4053) into the front cross member as shown in ILLUSTRATION 8, 1/2" X 2 3/4" bolts and spacers (PN 90-2014) provided. Make sure the bolts are inserted from the top. Torque the bolts to specifications.
14. Mount the assembled front cross member to the existing front lower A-arm pockets with the OEM bolts and nuts with heads to front. The steering link units are oriented to the rear as seen in ILLUSTRATION 8. Tighten to specs. *Please note: you may have to clearance the frame above the bolt heads that secure the Steering link supports (PN 90-4053) to the front cross member to avoid contact.*

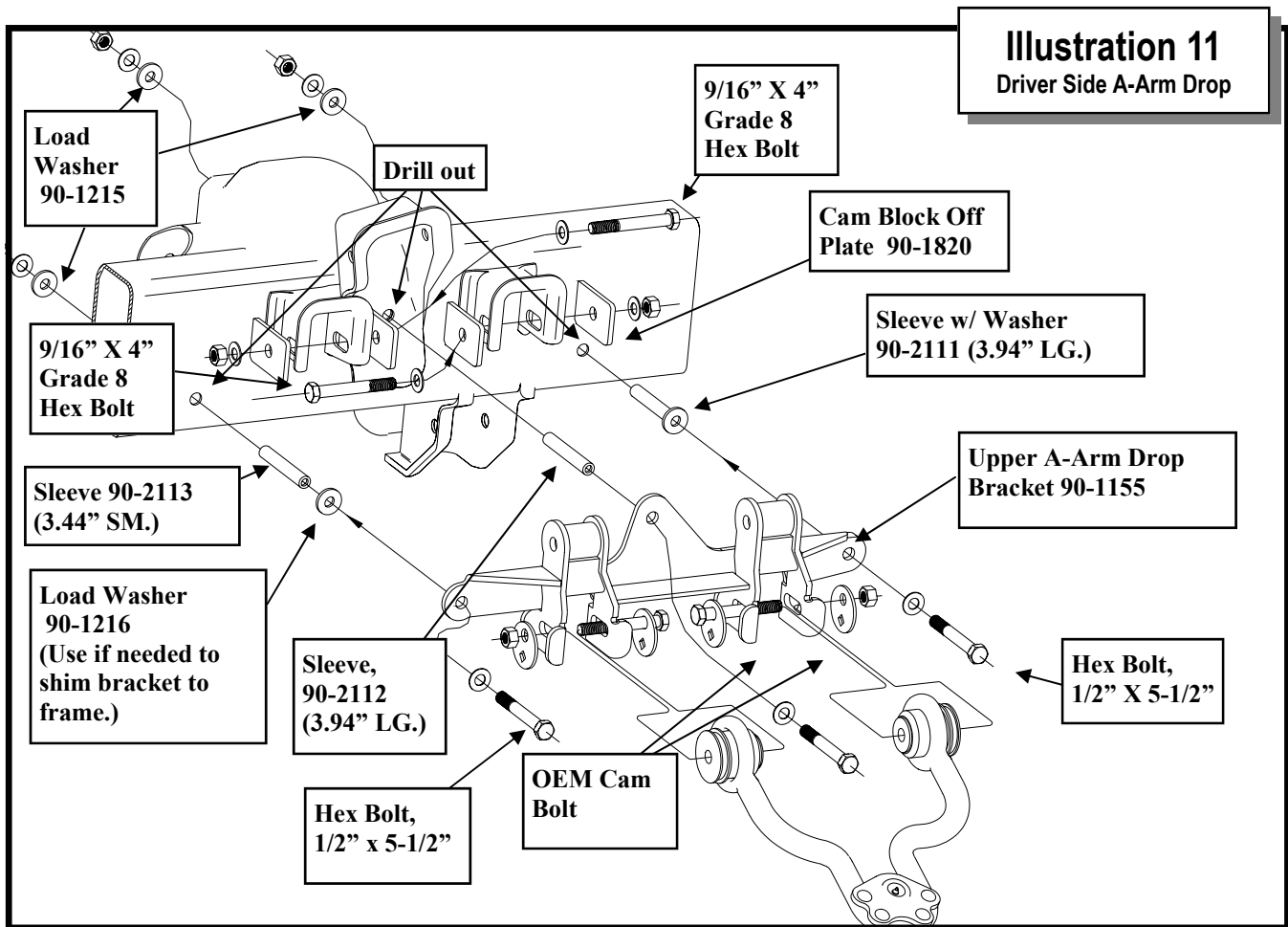

Illustration 11
Driver Side A-Arm Drop

NOTE: Due to space constraints if you are installing a Genuine Truck Accessories steering stabilizer kit 217513, install the mount and hardware detailed in the following step at this time. If you are not installing a stabilizer at this time it is highly recommended that you follow the next step anyway to aid in a potential future installation.

15. Place the center link drop (PN 90-2354) on a bench and insert the sleeves (PN 90-2394), mount (if applicable) and 3/8" X 2 1/2" bolts with the threads facing the front of the vehicle through the holes on the passenger side of the center link drop. Use ILLUSTRATION 8 to show the proper orientation of center link drop in the vehicle and location of stabilizer mount. Torque bolts to 20 ft lbs.
16. Install the center link drop (PN 90-2354) to the pitman arm and idler arm using the OEM nuts. Notice that the center link drop taper ends are welded at slightly different angles on each end of the drop. There is a mount for the steering stabilizer on either end. This mount is oriented to the top right of the center link drop. Use ILLUSTRATION 8 for reference. When properly installed, the center link will NOT contact the differential and the support links will align properly.
17. Connect the factory center link to the center link drop (PN 90-2354) and the steering links (PN 90-4053) from the front cross member using the 1/2" X 4" bolts, spacers (PN 90-2055), and reducer cones (PN 90-4036) provided. Follow the assembly shown in ILLUSTRATION 8.

NOTE: If you are installing steering stabilizer kit 217513 do so at this time.

18. Install the driver side upper a-arm drop bracket (90-1155) into the stock a-arm location points and onto the frame. Reference ILLUSTRATION 11 and note the following

a) Temporarily bolt (or hold tightly) the new upper a-arm drop bracket in place. Use an angle indicator to insure the bracket sits parallel (90 degrees) to the frame rail. If it doesn't, grind a little more where the bump stop was cut off.

b) Once positioned, use the upper a-arm drop bracket as a guide to drill the 3 necessary 1/2" holes in the frame.

c) Enlarge the two holes in the outer face only of the frame to 3/4" so that the anti-crush sleeves (PN 90-2112 and PN 90-2113) can be inserted into them. The holes on the backside are only large enough for the bolts to protrude, not the sleeves. The sleeves are trapped between the inner frame wall and the drop bracket. The sleeves prevent the frame from crushing when the bracket's bolts are torqued to specifications during final assembly.

NOTE: The center hole uses the longer sleeve and the front hole uses the shorter sleeve

NOTE: If you are installing a Pro Comp shock hoop, install it at this time.

Illustration 12
Front Suspension

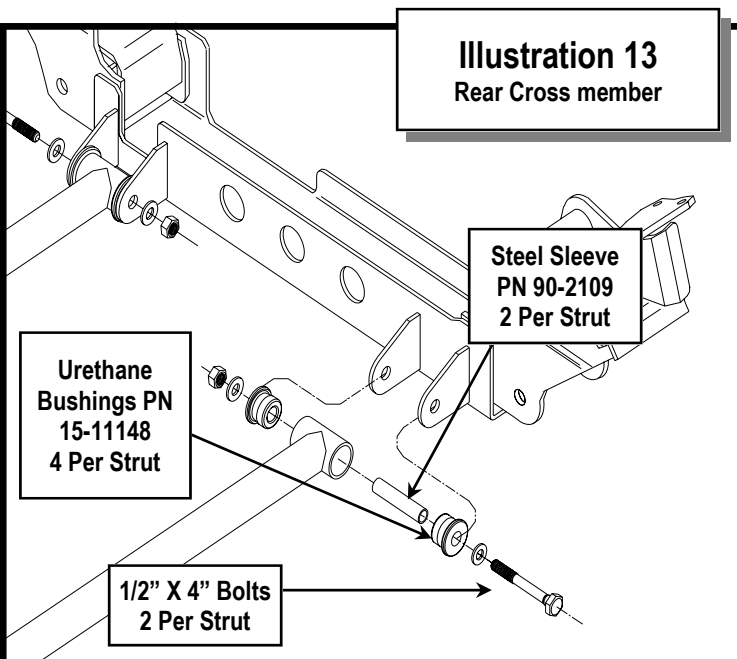
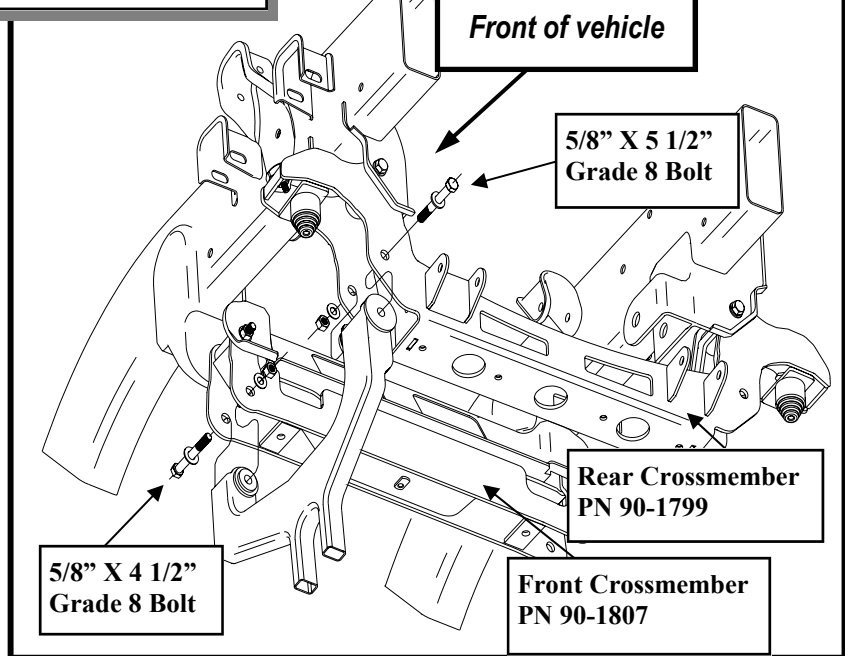

d) Install the upper a-arm drop bracket into the original bracket slots using the hardware provided as outlined in ILLUSTRATION 11.

⇒ **REPEAT STEP 18 ON THE PASSENGER SIDE.**

STEPS 19 THROUGH 26 ARE PERFORMED ONE SIDE AT A TIME:

19. Re-hang control arms. Start at the driver side. Both sides install identically. Raise the control arm assembly into position with a floor jack. Install with 5/8" hardware at the lower control arm attaching point with the threads pointing in at each other as shown in ILLUSTRATION 12. Now attach

upper control arm to brackets per ILLUSTRATION 11. Be sure that the anti-sway bar body is pivoted down so it is below the upper control arm's front leg. Install **OEM cam bolts** and adjust bolts to a neutral, or centered position (torque to 75-90 ft./lbs.)

20. Attach CV axle flange to differential. Use OEM bolts and loctite. Torque to 60 ft./lbs.
21. Raise the lower control arm using the floor jack. Attach the front knuckle to the upper ball joint. Fasten with the OEM nuts.
22. Torque the lower ball joint nut to 94 ft./lbs.
23. Torque the upper ball joint nut to 74 ft./lbs.
24. Install the front caliper assemblies to each side of the vehicle. Install the ABS sensor wiring and secure them to the brake lines with zip-ties. Again, the harness must be routed to prevent breakage or chaffing. **IMPORTANT: Move the A-arm assembly up and down to its limits several times to check for binding and to ensure that there are no interference or pinching problems with the brake lines and ABS wiring.**
25. Reinstall the tie rod ends and fasten with the OEM nuts.
26. Torque the tie rod ends to 40 ft./lbs

Repeat steps 19 through 26 on the remaining side of the vehicle:

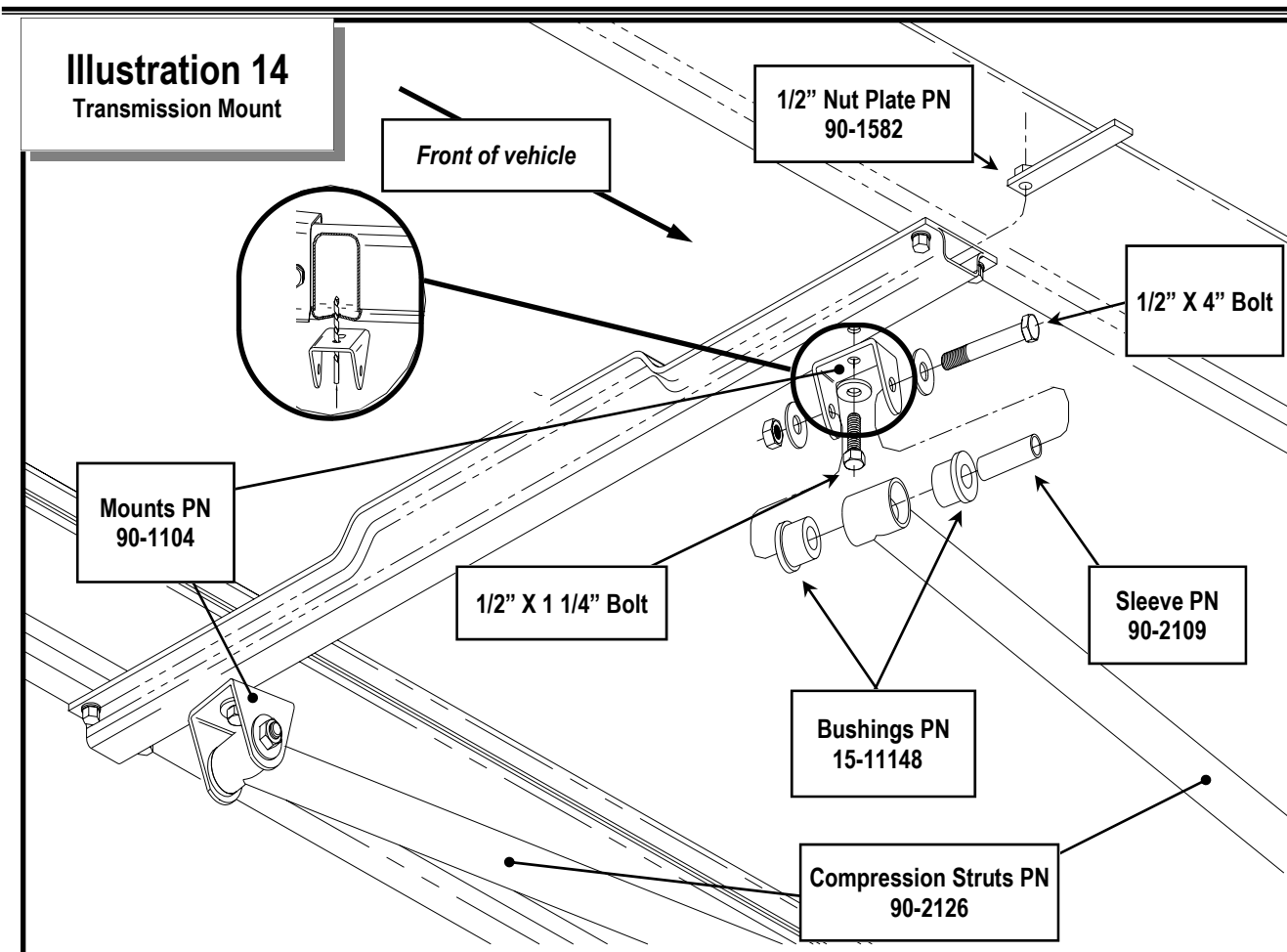

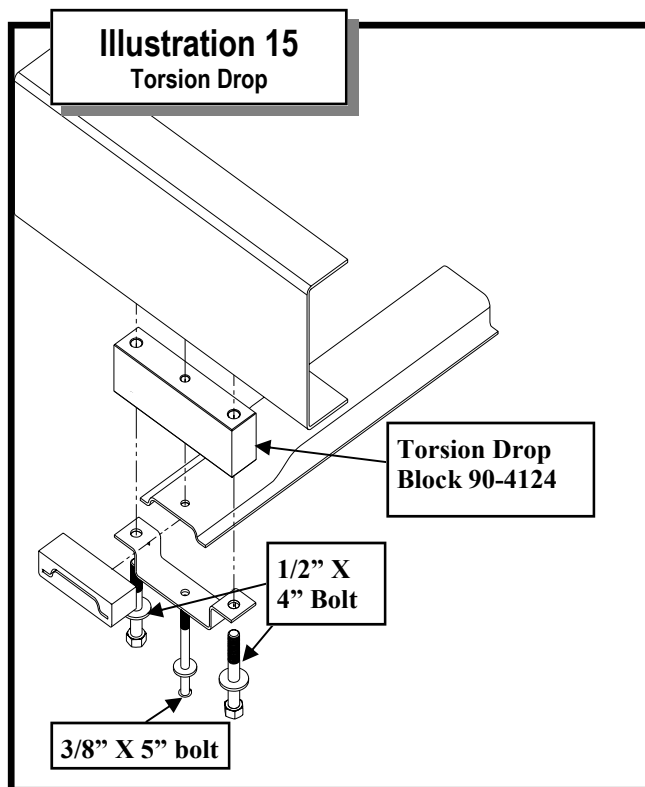

27. Assemble both ends of the compression struts as shown in ILLUSTRATION 13 & 14 using the bushings (PN 15-11148) and sleeves (PN 90-2109).
 28. Position the compression struts (PN 90-2126) into the tabs on the rear cross member using the supplied 1/2" X 4" bolts, washers, and nuts. See ILLUSTRATION 13. The strut ends welded at an angle go to the front, the struts are angled from the front of the vehicle rearward to the outside of the vehicle.
 29. Rotate the strut up to the transmission cross member and test fit the mounts (PN 90-1104) until a satisfactory location is found. Mounts have offset holes and can be rotated 180 degrees to fit. After you have located the position of the holes, drill them out with a 1/2" drill bit and install the saddles (PN 90-1104) to the transmission crossmember with the supplied 1/2" X 1 1/4" bolts, washers, and 1/2" nut plates. See ILLUSTRATION 14. Rotate the struts back up and install the 1/2" X 4" bolts supplied. Repeat this procedure for the other side. Torque the compression strut hardware to specifications.
 30. Install the new steel brake hose (PN 7225-AB). Thoroughly clean all mating surfaces. Make sure old crush washers are removed. Attach the new grommet to the upper control arm mount with the hardware provided. Position hoses so they don't make contact with any other parts. Hoses must be able to slide unrestricted through the grommets.
 31. Install the front shock absorbers (PN 324501). Torque upper and lower bolts to 48 ft./lbs. Cycle suspension through the full travel cycle and check for adequate clearance between shocks, bump stops and brake hoses. Brake hose should be routed behind shocks. Make sure brake lines are clean and dry of any material before ABS brake bleeding.
- *On 97 and later vehicles it may be necessary to invert the front shocks to provide adequate clearance with the upper control arm. See parts pack 90-6085 for detailed instructions.*
32. Reinstall the differential vent hose and wiring harness.
 33. Re-install the factory front anti-sway bar end links. Both sides install identically. Tighten end link bolt just until bushings swell slightly.
 34. Reinstall the front driveshaft. If it does not clear the exhaust crossover pipe, re-route a new section of pipe either above or below the shaft. If necessary, the vehicle can be driven with the front shaft completely removed. Torque hardware to factory specifications.

NOTE: *Manually turn driveshaft and check the U-joints for binding. If U-joints do bind flip driveshaft 180 degrees with slip yoke now facing front of truck.*

35. Re-install the torsion bar cross member by flipping torsion crossmember brackets so they mount under the frame, install the new aluminum torsion bar drop brackets (**PN 90-4124**) as shown in ILLUSTRATION 15. Torque all fasteners to spec.
36. Install the torsion bars by reversing the order in which they were removed. Again, be very careful to install them with the same orientation that they were removed (i.e. left front to left front, right front to right front!).

NOTE: Load the torsion bars by reversing the sequence of ILLUSTRATION 1, again being very careful. Tighten until arms are just clearing nut blocks both sides. Load torsion bolts to original measurements taken from step 5 in front disassembly.

RECHECK CLEARANCES:

1. **With vehicle still on jack stands and suspension hanging at full extension travel, cycle steering lock to lock to check all components for proper operation and clearance. Make sure brake lines and ABS lines do not come in contact with tires. If they do reposition them.**
2. **Thoroughly bleed air from brake system as per the factory service manual's instructions.**
3. **Reinstall front wheels at this time**
4. **WITH VEHICLE ON THE GROUND GO THROUGH AND TIGHTEN/TORQUE ALL BOLTS TO REQUIRED SPECIFICATIONS ACCORDING TO THE SPEC CHART AT THE END OF THE INSTRUCTIONS. CYCLE STEERING AND CHECK FOR CLEARANCE OF BRAKELINE AND ABS ROUTING. DO NOT RE-TIGHTEN BOLTS WHERE LOCTITE WAS USED. ⚠**

REAR INSTALLATION:

ADD-A-LEAF (13124) INSTALLATION

NOTE: In order to properly install the add-a-leaf spring, it will be necessary to contain the elasticity in the leaf spring with "C" clamps when the center bolt is removed. Some springs have a factory helper spring consisting of one or more flat leaves installed at the bottom of the leaf pack. DO NOT install the add-a-leaf spring in or below the helper spring.

- 1) Place floor jack underneath rear axle and raise vehicle. Place jack stands under frame to support vehicle and remove rear wheels.
- 2) With the floor jack, raise the rear axle enough to relieve tension on the shock absorbers and remove them. Disconnect the axle vent hose from the axle housing.

- 3) Remove the axle u-bolts. Remove the spring eye bolts and/or shackles and remove the springs from the vehicle.
- 4) Hold the spring assembly securely together with "C" clamp. Remove any spring leaf alignment clamps. Remove the spring center bolt. A hammer and drift punch may be used to drive it out if necessary.
- 5) Carefully remove "C" clamps and lay un-assembled spring aside.

NOTE: Add-a-leaf will be placed in the spring assembly progressively according to length. For example, if the existing leaves are 32" long and 25" long and the add-a-leaf is 28" long, place the add-a-leaf between the exist-

Illustration 16
Rear Leaf Spring Assembly

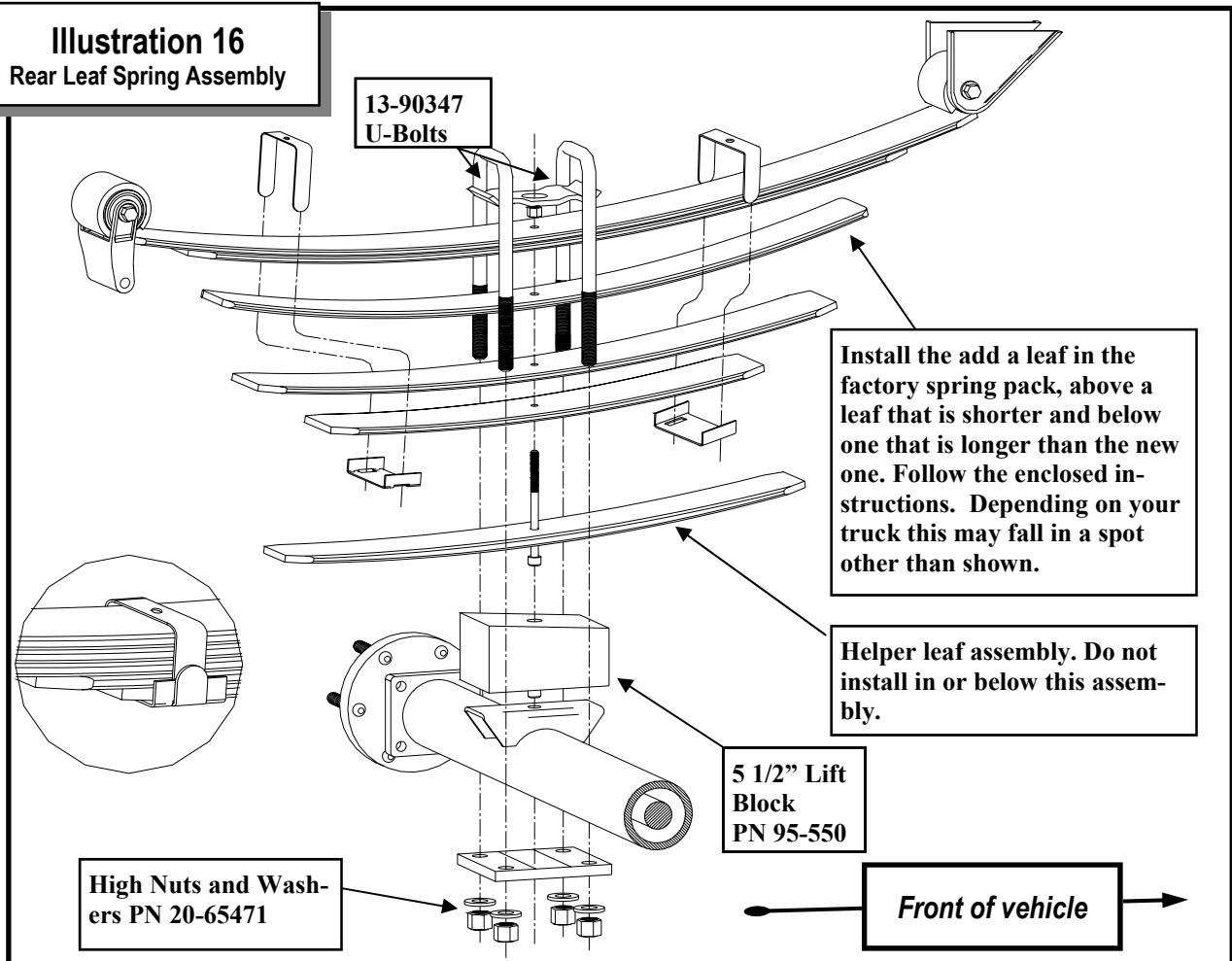

ing leaves.

- 6) Apply a small amount of grease to the end of the add-a-leaf, place it in the spring assembly as described in the note above, and reassemble the leaf springs using the "C" clamps.
- 7) Insert the new center bolt and torque the center bolt nut to 20 ft./lbs. Install new leaf alignment clamps as shown in illustration 18. With a hacksaw, cut the center bolt even with the top of the nut.
- 8) Loosely assemble the complete spring assemblies into their respective axle mounts. As shown in ILLUSTRATION 16, place the riser blocks in position. Make sure the pin in the block is in the hole of the axle housing spring pad. The short end of the block goes toward the front of the vehicle. Install the block so the pinion moves up.

- 9) Raise the axle housing up until the pin in the spring aligns with the hole in the block.
- 10) Re-mount the axle to the springs using the new u-bolts, washers and nuts and the existing spring plates; tighten and torque u-bolt nuts to 85-100 ft./lbs. See ILLUSTRATION 17.
- 11) Re-mount the axle vent hose and install rear shock absorbers (PN 329500).

NOTE: It may be necessary on some vehicles equipped with a one piece drive shaft to remove the rear frame brace in order to avoid contact with the driveshaft. Remove the rivets out and take out the brace and flip it around so that the driver side is now on the passenger side and re-mount it on the bottom of the frame.

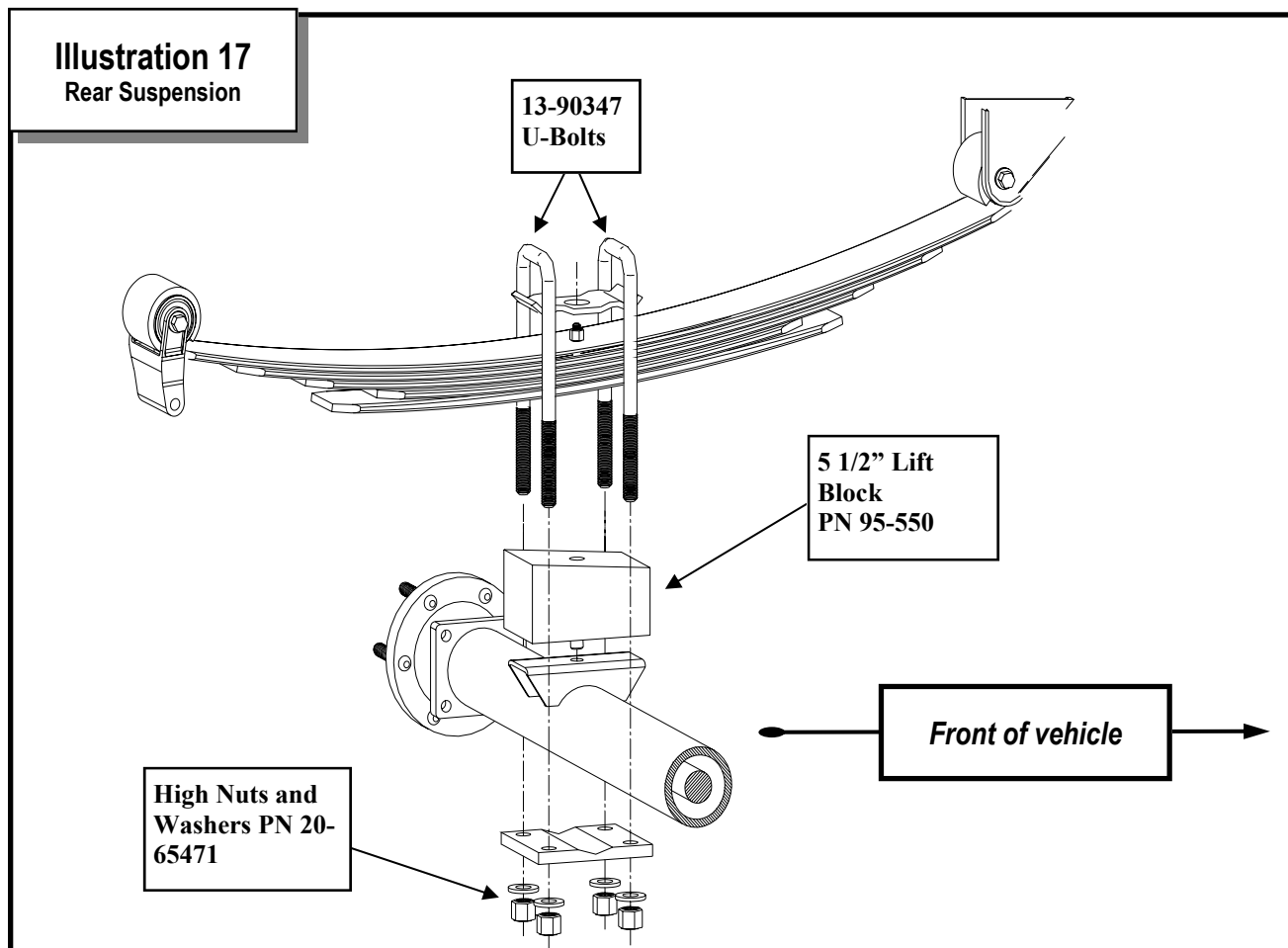

- 12) pre-settle the bars and springs. Evenly adjust-up the torsion bar bolts until the front of the vehicle is approximately 1/2" above the final desired ride height. Bars will settle slightly after vehicle is driven.

NOTE:

- ⇒ *Make sure to check rear brake line for any pinching, rubbing or excess stretching. Modify rear drop if needed.*
- ⇒ *Each bar may require slightly different adjustment to level vehicle side to side.*
- ⇒ *At maximum ride height, there still must be at least 3/16" of clearance between the bump stop and the front lower control arm. Operating the vehicle with less bump stop clearance will result in a harsh ride and accelerated suspension component wear. ⚠*

Final notes:

- 1. If new tires are installed that are more than 10% taller than original tires, the speedometer must be recalibrated for the rear wheel anti-lock brake system to function properly. Contact an authorized GM dealer for details on recalibration.**
- 2. With vehicle on the floor, cycle the steering from lock to lock and inspect the steering, suspension and driveline systems for proper operation, tightness and adequate clearance. Recheck brake hose/fittings for leaks. Be sure all brake lines are long enough for safe operation.**
- 3. Have headlights readjusted to the proper settings.**
- 4. Realign front end to factory specifications. Be sure the vehicle is at the desired ride height prior to realignment.**
- 5. Recheck ALL fasteners at 100 miles to make sure they have not come loose. Due to the additional wear and tear created by larger tires and wheels, we recommend that you periodically check the suspension system and steering components to ensure service life and safe vehicle operation. ⚠**

Bolt Torque and ID

Decimal System

Metric System

All Torques in Ft. Lbs.

Bolt Size	Grade 5	Grade 8	Bolt Size	Class 9.8	Class 10.9	Class 12.9
5/16	15	20	M6	5	9	12
3/8	30	45	M8	18	23	27
7/16	45	60	M10	32	45	50
1/2	65	90	M12	55	75	90
9/16	95	130	M14	85	120	145
5/8	135	175	M16	130	165	210
3/4	185	280	M18	170	240	290

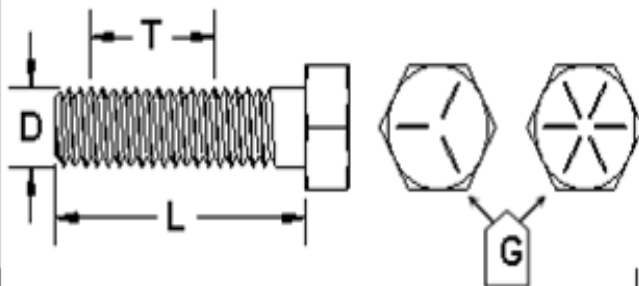

1/2-13x1.75 HHCS



Grade 5 Grade 8
(No. of Marks + 2)

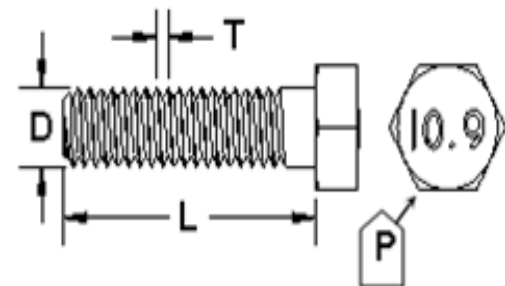

M12-1.25x50 HHCS



G = Grade (Bolt Strength)
D = Nominal Diameter (Inches)
T = Thread Count (Threads per Inch)
L = Length (Inches)
X = Description (Hex Head Cap Screw)

P = Property Class (Bolt Strength)
D = Nominal Diameter (Millimeters)
T = Thread Pitch (Thread Width, mm)
L = Length (Millimeters)
X = Description (Hex Head Cap Screw)

Notice to Owner operator, Dealer and Installer:

Vehicles that have been enhanced for off-road performance often have unique handling characteristics due to the higher center of gravity and larger tires. This vehicle may handle, react and stop differently than many passenger cars or unmodified vehicles, both on and off-road. You must drive your vehicle safely! Extreme care should always be taken to prevent vehicle rollover or loss of control, which can result in serious injury or even death. Always avoid sudden sharp turns or abrupt maneuvers and allow more time and distance for braking! Genuine Truck Accessories reminds you to fasten your seat belts at all times and reduce speed! We will gladly answer any questions concerning the design, function, maintenance and correct use of our products.

Please make sure your Dealer/Installer explains and delivers all warning notices, warranty forms and instruction sheets included with Genuine Truck Accessories products.

Application listings in this catalog have been carefully fit checked for each model and year denoted. However, Genuine Truck Accessories reserves the right to update as necessary, without notice, and will not be held responsible for misprints, changes or variations made by vehicle manufacturers. Please call when in question regarding new model year, vehicles not listed by specific body or chassis styles or vehicles not originally distributed in the USA.

Please note that certain mechanical aspects of any suspension lift product may accelerate ordinary wear of original equipment components. Further, installation of certain Genuine Truck Accessories products may void the vehicle's factory warranty as it pertains to certain covered parts; it is the consumer's responsibility to check with their local dealer for warranty coverage before installation of the lift.

Warranty and Return policy:

Genuine Truck Accessories warrants its full line of products to be free from defects in workmanship and materials. Genuine Truck Accessories obligation under this warranty is limited to repair or replacement, at Genuine Truck Accessories option, of the defective product. Any and all costs of removal, installation, freight or incidental or consequential damages are expressly excluded from this warranty. Genuine Truck Accessories is not responsible for damages and / or warranty of other vehicle parts related or non-related to the installation of Genuine Truck Accessories product. A consumer who makes the decision to modify his vehicle with aftermarket components of any kind will assume all risk and responsibility for potential damages incurred as a result of their chosen modifications. Warranty coverage does not include consumer opinions regarding ride comfort, fitment and design. Warranty claims can be made directly with Genuine Truck Accessories or at any factory authorized Genuine Truck Accessories dealer.

IMPORTANT! To validate the warranty on this purchase please be sure to mail in the warranty card.

Claims not covered under warranty-

- Parts subject to normal wear, this includes bushings, bump stops, ball joints, tie rod ends and heim joints
- Discontinued products at Genuine Truck Accessories discretion
- Bent or dented product
- Finish after 90 days
- Leaf or coil springs used without proper bump stops
- Light bulbs
- Products with evident damage caused by abrasion or contact with other items
- Damage caused as a result of not following recommendations or requirements called out in the installation manuals
- Products used in applications other than listed in Genuine Truck Accessories catalog
- Components or accessories used in conjunction with other manufacturer's systems
- Tire & Wheel Warranty as per Genuine Truck Accessories Company policy
- Warranty claims without "Proof of Purchase"
- Genuine Truck Accessories Pro Runner coil over shocks are considered a serviceable shock with a one-year warranty against leakage only. Rebuild service and replacement parts will be available and sold separately by Genuine Truck Accessories. Contact Genuine Truck Accessories for specific service charges.
- Genuine Truck Accessories accepts no responsibility for any altered product, improper installation, lack of or improper maintenance, or improper use of our products.

Tech Department
Ph: (619) 216-1444

<p><u>PLACE</u> <u>WARRANTY NUMBER</u> <u>HERE:</u> _____</p>
--