

Installation Instructions



Stryker Front Bumper
Part # S/B76730
2007-Present JK/JL/JT



For Technical Support / Warranty Information please call 1-800-776-0767
Smittybilt, 400 W Artesia, Compton, CA 90220

Introduction

Thank you for choosing Smittybilt accessories for your Jeep Wrangler® or Gladiator®. If you would like to view our full range of available accessories, please visit us at www.smittybilt.com



Stryker Rear Bumper

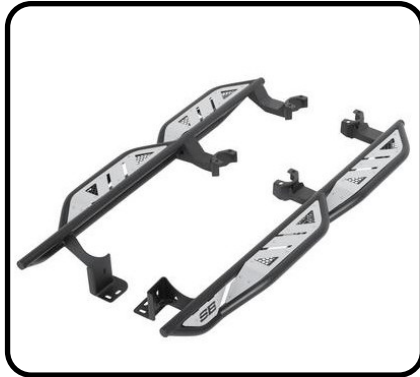

Apollo Rock Sliders with Steps



JK/JL/JT Neoprene Seat Covers

Jeep®, Wrangler®, & Gladiator® are registered trademarks of Stellantis N.V.

Important Notes Before Starting

! IMPORTANT NOTE

Carefully read through this entire instruction manual thoroughly before attempting to install this part.

! IMPORTANT NOTE

This bumper fits 2007-2018 JK, 2018+ JL, and 2020+ JT model Jeeps. Steps may vary.

! IMPORTANT NOTE

This installation was performed on a Sahara JL, steps may vary depending on vehicle model and trim.

! WARNING

Park vehicle on flat surface, chock all four wheels and engage parking brake prior to installation.

Serious injury can occur when working on vehicles alone. When possible, work with another person to reduce risk of injury from strain or other dangers that can occur when working alone.



For Technical Support / Warranty Information please call 1-800-776-0767
Smittybilt, 400 W Artesia, Compton, CA 90220

Box Contents

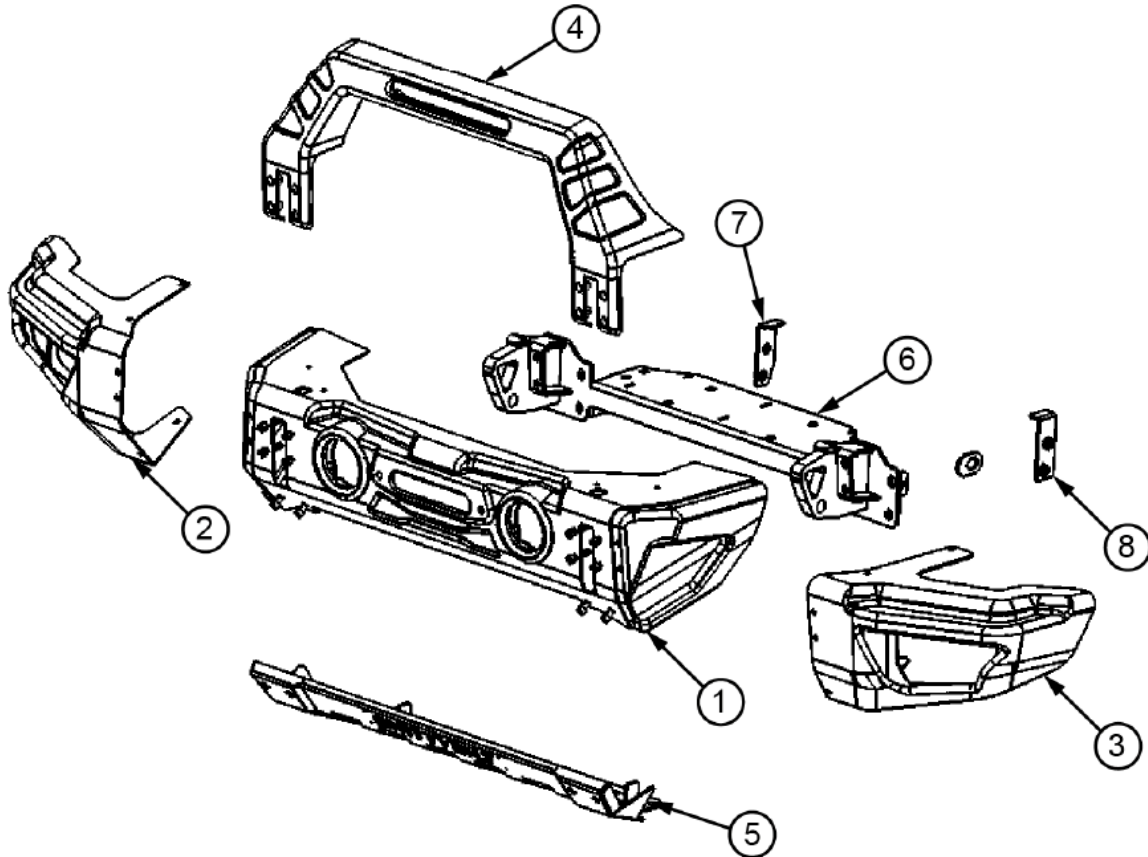

ID	Part Description	QTY
1	Stryker Bumper Center Section	1
2	76731-01 - Left Wing (Sold Separately)	1
3	76731-02 - Right Wing (Sold Separately)	1
4	Override Bar	1
5	Skid Plate	1
6	Winch Cradle	1
7	Left Nut Plate	1
8	Right Nut Plate	1
	Lower Cover Bracket	1
	M8-1.25x20mm Allen-Head Screw	16
	M8-1.25 Nylock Nut	6
	M8 Split Lock Washer	6
	M10-1.5x25mm Hex Bolt	9

Part Description	QTY
M8 Flat Washer	6
M10-1.5x45mm Button Cap Screw	12
Nut Plate	4
M12-1.75x35mm Hex Bolt	12
M12-1.75 Nylock Nut	12
M12 Flat Washer	24
M10-1.5x25mm Hex Bolt	9
M10 Flat Washer	18
M4x19mm Button Head Screw	8
Plastic Plug	8
Left Winch Bracket	1
Right Winch Bracket	1



For Technical Support / Warranty Information please call 1-800-776-0767
Smittybilt, 400 W Artesia, Compton, CA 90220

Installation Instructions: Stryker Installation

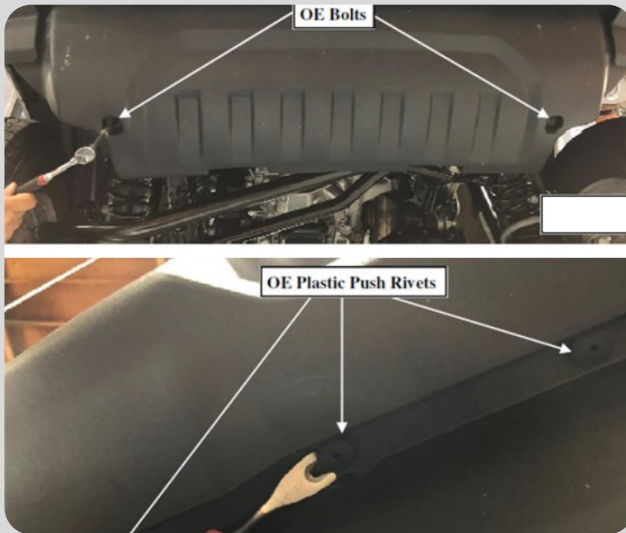

Step 1:

Remove the **(2) OE bolts** and **(8) OE plastic push rivets** securing the plastic skid plate to the **OE metal skid plate**. Remove the plastic skid plate.

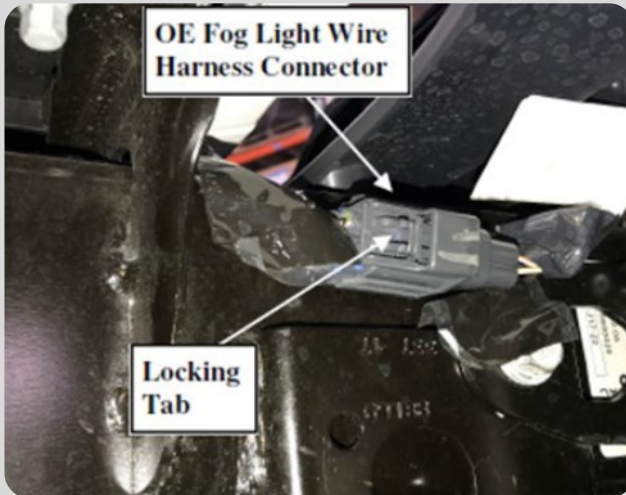

Step 2:

Depress the locking tab and disconnect the **OE fog light wiring harness connector** located on the passenger side of the vehicle.

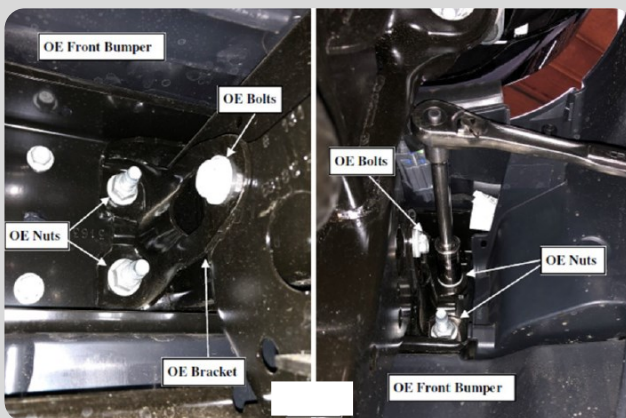

Step 3:

Remove the **(2 per side) OE nuts** and **(1 per side) OE Bolts** securing the **OE front bumper and brackets** to the frame.



For Technical Support / Warranty Information please call 1-800-776-0767
Smittybilt, 400 W Artesia, Compton, CA 90220

Installation Instructions: Stryker Installation

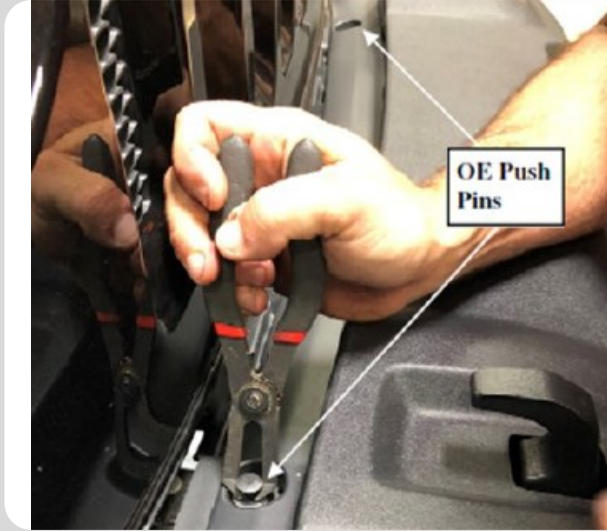

Step 4:

Remove the upper bumper plastic trim by removing the (2) **OE Push Pins**.

Step 5:

Carefully remove the **OE Front Bumper** from the vehicle.

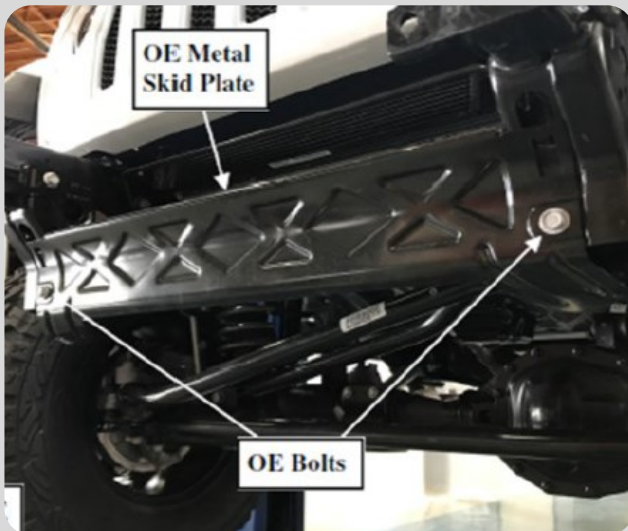

Step 6:

Remove the (2) **OE Bolts** securing the **OE Metal Skid Plate** and remove the skid plate from the frame rails. Save the **OE Hardware** for re-installation later.

Note: If not reusing the fog lights from the OE bumper, proceed to Step 10.

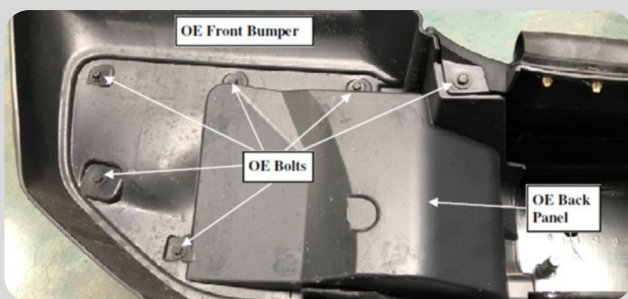

Step 7:

Using a **7mm socket**, remove the (6 Per Side) **OE Screws** securing the **OE back panels** from the **OE front bumper**.



For Technical Support / Warranty Information please call 1-800-776-0767
Smittybilt, 400 W Artesia, Compton, CA 90220

Installation Instructions: Stryker Installation

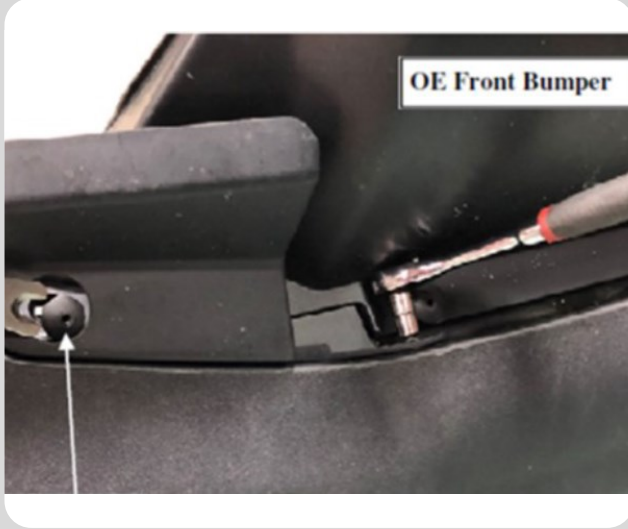

Step 8:

Remove the **(1 per side)** OE plastic push rivet. Using a **7mm socket**, remove the **(1 Per Side)** remaining OE screw securing the **back panel**. Then remove the **back panel** from the OE front bumper.

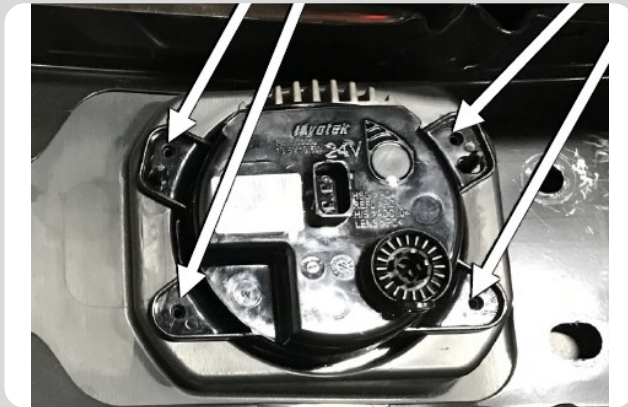

Step 9:

Disconnect the wiring harness from the back of each OE Fog Light. Then, remove the **(4 per light)** OE Screws that secure the fog lights to the OE Bumper. Set the lights aside for installation into the Stryker Front Bumper.



Step 10:

Install the **(2) Nut-Plates** into the top inner frame supports on your Jeep. Make sure the tabs are facing inwards.



For Technical Support / Warranty Information please call 1-800-776-0767
Smittybilt, 400 W Artesia, Compton, CA 90220

Installation Instructions: Stryker Installation

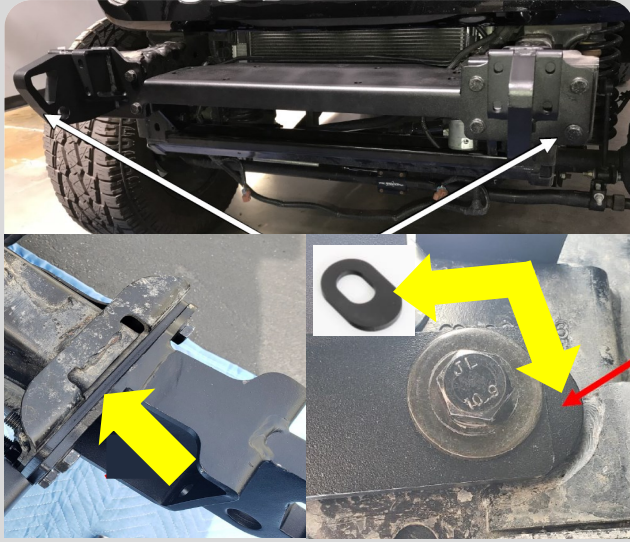

Step 11:

Install the **Winch Cradle** to the OE frame horns using the supplied **M12 Hardware**. Install **washers and nuts** on just the outside bolts at this time.

JL/JT Owners Only: Be sure to install the flat rectangular spacer plates between the frame horn and shackle mount section of the winch cradle before installing hardware. Be sure to install the oval spacers between the winch plate and nut-plates (from Step 10).

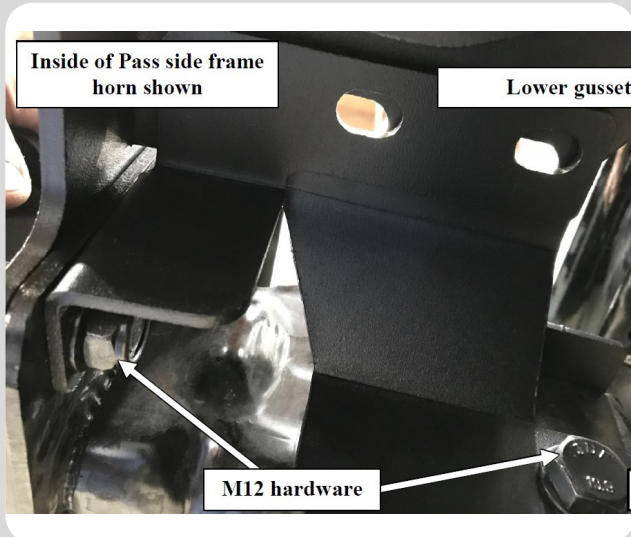

Step 12:

Install the lower support gussets under the winch cradle to the back of the inside frame horn bolts. Secure with the included **M12 Hardware**. Secure the winch cradle to the nut-plates installed in the frame supports with the provided **M12 Hardware** through the support gussets.



Step 13:

Adjust the winch cradle assembly so that it is level to the grill and frame rails. When satisfied, tighten all **M12 Hardware** to **70ft-lbs**.

Step 14:

If installing a winch, do so at this time, following the instructions included with the winch.



For Technical Support / Warranty Information please call 1-800-776-0767
Smittybilt, 400 W Artesia, Compton, CA 90220

Installation Instructions: Stryker Installation



Step 15:

Install the **OE or Aftermarket Fog Lights** into the **Stryker Center Section** using the supplied **M4 Hardware** provided.

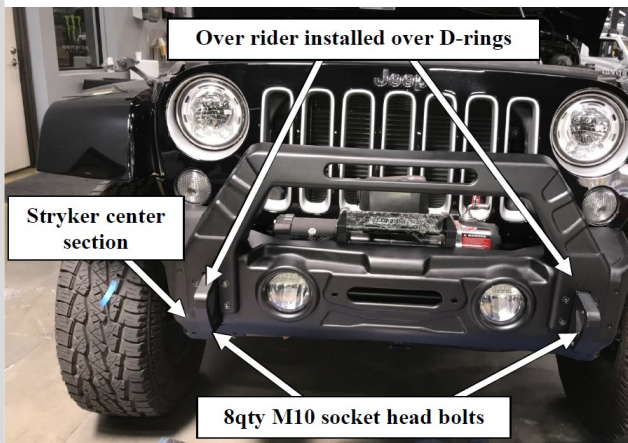

Step 16:

Install the **nut-plates** behind the shackle mounts. Mount the bumper onto the **Winch Cradle**, on top of the winch cradle and shackles, then install the over-rider bar on top of the bumper. Then secure the bumper using the included **M10 Hex Head Bolts**. Secure the over-rider bar using the included **M8 Hardware**.

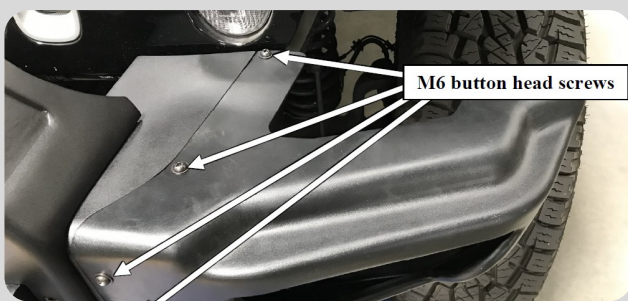

Step 17:

If installing **S/B76731 (sold separately)** install using the included **(5 Per Side) M6 Hardware**. If installing off-road lights, do so now, using the instructions included with the lights.



For Technical Support / Warranty Information please call 1-800-776-0767
Smittybilt, 400 W Artesia, Compton, CA 90220

Installation Instructions: Stryker Installation

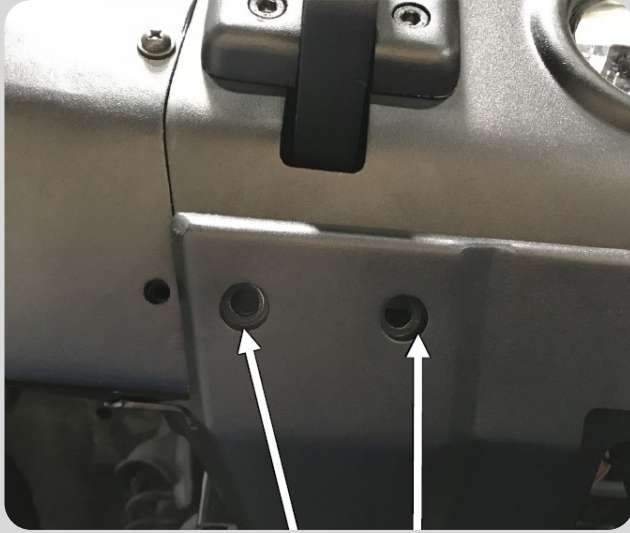

Step 18:

Mount the skid plate to the bottom of the **Stryker Center Section** using the 4 (2 Per Side) provided **M10 Allen Head Bolts**.

Step 19 (JK Only):

Bolt the lower portion of the **Skid Plate** to the lower crossmember using the supplied **M10 Hardware**. Tighten upper and lower hardware to **40ft-lbs**.

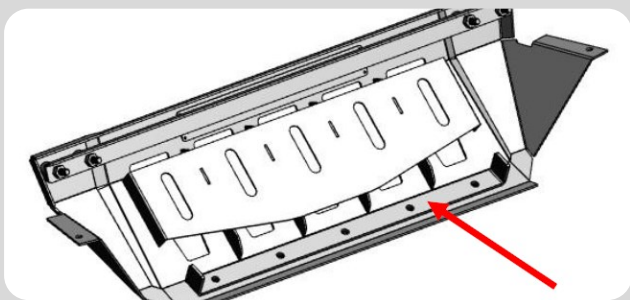

Step 20 (JL/JT Only):

Install the supplied **Skid Plate Strap** to the two lower frame horns using the supplied **M10 Hardware**. Then secure the **Skid Plate** to the **Strap** using the supplied **M10 Hardware**, then torque to **40ft-lbs**.

Step 21:

Install the **OE Fog Light Harness** into the new bumper. Connect the harness to the fog lights and carefully secure the rest of the harness out of the way of any pinch points or moving parts

Installation is now complete.



For Technical Support / Warranty Information please call 1-800-776-0767
Smittybilt, 400 W Artesia, Compton, CA 90220

Installation Instructions: Light Bar Installation



Step 1:

For light bars shorter than 13”:
Loosely attach the included **Light Adapter Brackets** to the light bar.



Step 2:

Loosely attach the **Light Adapter Brackets** to the override bar using the included **M8 Hardware**.



Step 3:

Once all the hardware is loosely installed, make sure the light is centered. Then tighten all hardware securely. Use the instructions included with the light bar for proper wiring.

Installation is now complete.



For Technical Support / Warranty Information please call 1-800-776-0767
Smittybilt, 400 W Artesia, Compton, CA 90220

Bolt Torque Specifications

Use this only as a guide for hardware without a called out torque specification in the instruction manual.

Bolt Torque and ID						
Decimal System			Metric System			
<i>All Torques in Ft. Lbs. Maximums</i>						
Bolt Size	Grade 5	Grade 8	Bolt Size	Class 9.8	Class 10.9	Class 12.9
5/16	15	20	M6	5	9	12
3/8	30	45	M8	18	23	27
7/16	45	60	M10	32	45	50
1/2	65	90	M12	55	75	90
9/16	95	130	M14	85	120	145
5/8	135	175	M16	130	165	210
3/4	185	280	M18	170	240	290

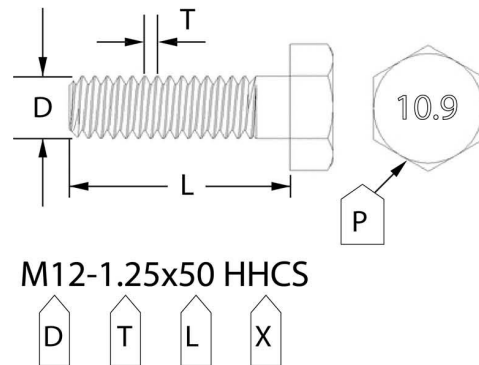
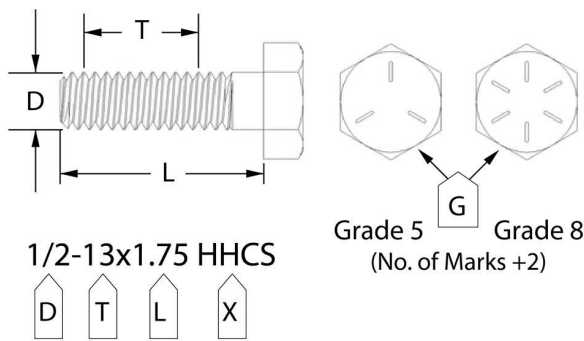

G= Grade (Bolt Strength)

D= Nominal Diameter (Inches)

T= Thread Count (Threads per Inch)

L= Length (Inches)

X= Description (Hex Head Cap Screw)

P= Property Class (Bolt Strength)

D= Nominal Diameter (Millimeters)

T= Thread Pitch (Thread Width, mm)

L= Length (Millimeters)

X= Description (Hex Head Cap Screw)



For Technical Support / Warranty Information please call 1-800-776-0767
Smittybilt, 400 W Artesia, Compton, CA 90220

Notes and Disclaimers

Product cleaning and maintenance instructions

Stainless Steel Finish – Aluminum polish may be used to polish small scratches and scuffs on the finish. Mild soap, window or glass cleaner may be used to clean the finish. Dual state powder coat finish – Mild soap, window or glass cleaner may be used to clean the finish. In order to protect the finish, you may wax your product on a regular basis with pure carnauba automotive wax. Do not use any types of soap, polish or wax that contains abrasive that could damage the finish. Textured coated finishes should be cleaned with a mild soap on a damp sponge. Do not apply polish or wax that requires to be removed by means of buffing. This type of wax is commonly used at car wash facilities. Chrome Finish – Mild soap, window or glass cleaner may be used to clean the finish. In order to protect the finish, you should wax your product on a regular basis with pure carnauba automotive wax. Do not use any types of soap, polish or wax that contains abrasive that could damage the finish.

SMITTYBILT ADVANTAGE WARRANTY

LIMITED-LIFETIME WARRANTY FOR STRUCTURAL COMPONENTS

5-YEAR FINISH WARRANTY

Smittybilt Automotive Products, LLC (SAP) warrants to the original purchaser that (a) the physical components (e.g., metal components, welds, etc.) of any SAP **Stryker Front Bumper** will be free of defects in material and workmanship for the lifetime of the product from the date of purchase of the bumper, and (b) the finish will be free of defects in material and workmanship for a period of 5-years from the original date of purchase. This warranty applies only to the original purchaser of the bumper and is non-transferable. To obtain any warranty service, you must provide SAP with a proof of purchase and date of purchase that is acceptable to SAP, such as a copy of your purchase receipt.

This warranty does not cover labor of part replacement of the bumper. SAP will, at its sole discretion, provide replacement part (s) for a defective bumper or component, provided this is done within the warranty period. To request assistance under warranty, one must call or email using the phone number or email at the bottom of this page. This warranty does not apply (1) wearable components; or (2) if the bumper has been damaged, including, but not limited to: abuse, misuse, collision, modification, misapplication, improper installation, or improper service. This warranty is void if any SAP serial number has been removed or defaced; or if bumper is used for any commercial, industrial, or rental applications. This warranty only applies to Stryker Front Bumpers bought, sold, and used within the United States or Canada unless otherwise specifically agreed in writing by SAP.

THE WARRANTY SET FORTH ABOVE IS THE ONLY WARRANTY. THERE ARE NO OTHER WARRANTIES, EXPRESSED OR IMPLIED, INCLUDING BUT NOT LIMITED TO IMPLIED WARRANTIES OF MERCHANTABILITY OR FITNESS FOR A PARTICULAR PURPOSE. ANY IMPLIED WARRANTY WHICH BY LAW MAY NOT BE EXCLUDED IS LIMITED TO A DURATION OF ONE (1) YEAR FROM THE DATE OF ORIGINAL RETAIL PURCHASE OF THE PRODUCT. No SAP dealer, agent, or employee is authorized to make any modification, extension or addition to this warranty. SAP SHALL NOT BE LIABLE FOR SPECIAL, INDIRECT, INCIDENTAL OR CONSEQUENTIAL DAMAGES (INCLUDING, BUT NOT LIMITED TO, LOST PROFITS, DOWN TIME OR LOSS OF USE) UNDER ANY LEGAL THEORY, EVEN IF SAP WAS ADVISED OF THE POSSIBILITY OF SUCH DAMAGES. Some states do not allow the exclusion of implied warranties or the exclusion or limitation of liability for incidental or consequential damages, or limitations on how long an implied warranty lasts, so the above limitation or exclusion may not apply to you. This Warranty gives you specific legal rights. You may also have other rights that vary from state to state. SAP reserves the right to change product design without notice. In situations in which SAP has changed a product design, SAP shall have no obligation to upgrade or otherwise modify previously manufactured products. For warranty inquiries contact SAP at:

Smittybilt Automotive Products, LLC

Customer Service Department

Call 1-800-776-0767 or Email info@smittybilt.com



WARNING: Cancer and Reproductive Harm
www.P65Warnings.ca.gov



For Technical Support / Warranty Information please call 1-800-776-0767
Smittybilt, 400 W Artesia, Compton, CA 90220