



WWW.SMITYBILT.COM

Installation Instructions
Scout Trailer Kit
Part#87400

Assembly and Care Instructions



Visit the
Scout Trailer
Kit link.



Due to on going improvements, photos are for illustration purposes and may vary from actual product. Actual install will be similar. Shown with optional accessories, available separately.



WWW.SMITTYBILT.COM

Installation Instructions
Scout Trailer Kit
Part#87400

NOTE: Carefully read entire instructions thoroughly before attempting to assemble this part.

GENERAL SAFETY

- Read and understand all instructions. Failure to follow all instructions may result in injury, electric shock, or fire.
- The warnings, cautions and instructions discussed in this instruction manual cannot cover all possible conditions or situations that may occur. It must be understood by the builder/user that common sense and caution are factors that cannot be built into this product and must be supplied by the builder/user.
- When unpacking, make sure that the product is intact and undamaged. If any parts are missing or broken, please call 310-762-9944 as soon as possible. Notify carrier of any shipping damages. By signing for the shipment you release carrier from any freight damages and accept item in its current condition. Smittybilt is not responsible for an shipping damage that may occur from mishandling.
- Always wear ANSI-approved safety goggles. Protective foot wear, clothing and other safety gear is required when assembling.
- **WARNING:** Handling the wiring cord on this product will expose you to lead, a chemical known to the State of California to cause cancer, birth defects or other reproductive harm. ***Wash hands after handling.*** Cord has been covered in conduit to reduce exposure.
- **WARNING:** This product contains chemicals known to the State of California to cause cancer and birth defects or other reproductive harm.
- **WARNING:** Components of this trailer kit are heavy to handle. To avoid muscle strain or back injury, use lifting aids and proper lifting techniques when assembling and unpacking. It is suggested to have a minimum of two floor jacks, four jack stands and two people to aid in assembly.
- Keep work area clean and dry. Messy, unorganized or wet work areas promote injury.
- Keep children away from work area. Trailer kit is not a toy. Do not allow children to play in trailer kit or crate.

******Photos are for illustration only and actual product may vary. Install remains the same.******



WWW.SMITTYBILT.COM

Installation Instructions
Scout Trailer Kit
Part#87400

Operational Safety

- Recommendations are adapted from *TOWING A TRAILER-Being equipped for Safety*, which is published by the NHTSA. For a full publication contact the National Highway Traffic Safety Administration.
- This trailer kit is not a toy, do not allow children to play on or near trailer kit or crate.
- Familiarize yourself with trailer handling before driving on main roads. Short wheel base trailers will react quickly to changes in steering direction.
- Do not allow anyone to ride in or on the trailer. Do not transport animals in this trailer. Trailer compartments are air tight and pose a suffocation hazard.

Before each use

- Check all tires for proper inflation and damage. Repair/ inflate if necessary.
- Check torque of all lug nuts. Recommended torque for ½"-20 lug nuts is 85-95 ft.-lb. Always check wheel manufacture for proper torque specs.
- Check trailer for loose hardware, structural integrity and any other condition that may affect safe operation. Do not use this trailer kit if any damage is found until damage is repaired.
- Make sure all running lights, brake lights, turn signals and hazard lights are working properly. Inspect lights and wiring for any damage, replace any broken lenses, or reflectors, and repair any damaged wiring.
- Check to make sure break away system is charging when hooked up to tow vehicle when vehicle is running.
- Make sure all cargo are securely fastened in and on the trailer. Make sure all hitch pins are secured with a cotter pin or other securing device.
- Make sure parking brake is properly adjusted and functioning. Supplemental wheel chocks are recommended. Improperly adjusted parking brake may cause unwanted movement of trailer.
- Make sure safety chains are properly routed and not touching the ground and will allow for full turning of trailer. Make sure Break away tether is attached to the tow vehicle's frame. Do not hook cable to safety chain loop or hitch ball.



Installation Instructions

Scout Trailer Kit

Part#87400

WWW.SMITTYBILT.COM

- The trailer's safety chains' lengths MUST be short enough so the break away system tether is not pulled if the couple separates from the tow vehicle's hitch but remains connected by the safety chains. The breakaway system should only activate after BOTH the trailer's coupler and safety chains have failed and allowed the trailer to completely separate from the tow vehicle. Provide just enough slack in the safety chains to allow for tight maneuvers. Chain and trailer wiring should not touch the ground.
- **DO NOT use 2" ball style coupler for off-highway use.** Only use an articulating coupler, pintle hook and lunette ring or other articulating style of coupler for off-highway use. The standard ball coupler has minimal articulation and is only suited for highway use and has limited articulation. Excessive articulation of a standard 2" ball coupler may cause detachment from tow vehicle and/or damage to tow vehicle or trailer.
- Do not exceed the trailers maximum payload capacity of 1763 lb. Never exceed any of the capacities of any of the trailers features. Such as drawer capacity, rack capacity or payload capacity.
- Do not exceed capacity of tent mounting system, max load 250 lb dynamic, 800 lb static. Static load refers to the weight when vehicle is not in motion, for example when using a roof top tent on a stationary trailer with occupants should not exceed 800 lb. Dynamic capacity is the max capacity of rack system while vehicle is in motion. Always check local regulations on rack mounted loads.
- Make sure the towing vehicle and hitch are both rated to safely tow the trailer and its payload. Max weight of trailer and payload combined is 3306 lb.
- Take care in positioning of cargo items. Recommended tongue weight should not exceed 350 lb, but will vary by tow vehicles capacity. When positioning items make sure you evenly load items from side to side.
- Inspect tow vehicles' hitch, trailer wiring and hitch hardware before each use. Make sure all hardware is properly torqued.
- Never exceed hitch manufactures weight limits. Never exceed tow vehicles towing capacities. Towing capacities from the manufacture are normally listed for on-highway use. Off-highway use, depending on terrain, may greatly change these capacities. Always use good judgement when towing especially off-highway.
- Always re-adjust your brake controllers power setting each time you tow to avoid brake lock up and to make sure you have an adequate power setting to provide proper braking.



WWW.SMITTYBILT.COM

Installation Instructions
Scout Trailer Kit
Part#87400

Handling

- Always drive at moderate speeds. Allow for increased braking distances. Never exceed posted speed limits. This will help reduce strain on the tow vehicle and trailer.
- Avoid sudden braking and acceleration which can cause skidding, sliding or jack-knifing. Sudden steering maneuvers may create sway and excessive side force on trailer.
- Slow down when traveling off-highway, over railroad crossings, ditches, or extreme terrain.
- Allow extra space when turning. The trailers wheels will be closer to the inside of a turn than the wheels of your tow vehicle and they are more likely to hit an obstacle. When traversing an obstacle, always pick a line which will keep the trailer in the most level position. Avoid excessive articulation between trailer and tow vehicle.
- When getting passed by a large vehicle from either direction, slow down moderately and keep both hands on the wheel, as the vehicle passes it creates wind turbulence and wind buffeting which may cause excessive swaying of trailer.
- If excessive sway occurs, use your brake controller to moderately apply the trailer brakes. **DO NOT** attempt to control sway by pressing on the vehicles brakes, as this will generally make the sway worse.
- Some tow vehicles will have a tow-mode, always use the correct mode recommended by the manufacture.
- Short wheel base trailers will change directions rapidly when backing up. Only use slight movements of the steering wheel to adjust direction.
- Trailer will handle the best with a load. An empty trailer will be more bouncy than one with a load.

• **Parking**

Once trailer is in position but before shifting tow vehicle into park:

1. Apply the trailers parking brake and apply wheel chocks on the downhill side of the trailer wheels. Then engage tow vehicle parking brake.
2. Shift tow vehicle into PARK, then remove your foot from the brake pedal.

This sequence helps reduce load on the tow vehicles transmission and help prevent the transmission from being stuck in PARK due to extra load on the transmission.



WWW.SMITTYBILT.COM

Installation Instructions
Scout Trailer Kit
Part#87400

Parking cont.

- Always deploy stabilizer jacks before unhooking the trailer from the tow vehicle. Loads that have shifted may change the balance of the trailer. Remember to always secure loads properly to prevent shifting.
- Unhook trailer wiring from tow vehicle. The break away brake system uses power from the tow vehicle to recharge the internal battery, if left hooked up it will draw current from the tow vehicle. (dependent on tow vehicles trailer wiring setup) **DO NOT** use break away system battery to power any other devices.
- When parking or storing your trailer, keep the coupler off the ground so dirt will not build up in the hitch, ball socket or articulating hitch.
- After use in salt water environments, it is good practice to wash your trailer with fresh water as soon as possible. If trailer is used in winter and is subjected to road chemicals used to melt snow, wash with a mild detergent when you reach your destination.



WWW.SMITYBILT.COM

Installation Instructions
Scout Trailer Kit
Part#87400

Electric brakes

The brakes should be adjusted after installation and serviced as needed for the life of the brake system components. To adjust the brakes, use a brake adjustment screw tool to turn the adjustment gear on the inside of the assembly. Continue to turn the gear until the drum surrounding the bare catches on the brake pads enough, so that the hub cannot be rotated by hand easily. Then reverse the gear about 10 clicks. A properly adjusted brake should have a slight drag on the brake drum. It is recommended to re-adjust the brakes whenever servicing the bearings (every 3000 miles).

Break –in period

The break-in period is required for the brakes to achieve full performance. This break-in period applies for new axles and any time new brake shoes and/or magnets are installed as part of regular maintenance.

Brakes can be seated by applying approximately 8-10 volts to the trailer brakes at an initial speed of 35-40 mph while allowing the tow vehicle/trailer combination to slow down to 20-25 mph. Take care to not overheat the brakes; brake application should be conducted in one mile intervals. You should feel a notable difference in the brake performance during this period. After 10-30 applications, the brake shoes will be fully cured from the heat and will develop close to 100% contact with the brake drum. This break in period not only seats the brake shoes, but also seats the brakes electromagnets.

Note: Brakes should be manually adjusted after the first 200-300 miles of operation and periodically thereafter, normally 3000 miles intervals, when servicing the wheel bearings.

Use only genuine Axletek replacement brake parts when servicing your brakes. Smittybilt carries complete brake assemblies only. For individual replacement parts contact your local Axletek dealer.

Note: It is advised that after any river crossings, driving thru deep mud, deep sand, or water etc., you need to inspect/clean the brakes. If not cleaned out, mud can grind your brake shoes, drums and magnets away very quickly. Clean and dry brake assemblies completely before re- assembly. Be sure re-pack axle bearings each time you disassemble them.

Note: A brake controller must be used with electric brakes. Smittybilt recommends the Prodigy P3 electric brake controller, however there are many other great quality brake controllers on the market. Choose one that best suits your needs and has the features desired for your type of towing.



Installation Instructions

Scout Trailer Kit

Part#87400

Item	Function Required	Weekly	3 Months or	6 Months or	12 Months or
			3,000 Miles	6,000 Miles	12,000 Miles
Brakes	Test that they are operational	Test before every use			
Brake Adjustment	Adjust to proper operating clearance		X		
Parking Brake Adjustment	Adjust for proper tension and holding power		X		
Brake Magnets	Inspect for wear and current draw			X	
Brake Linings	Inspect for wear or contamination				X
Brake Controller	Check for incorrect amperage and modulation			X	
Brake Wiring	Inspect for cracks, tears, breaks in insulation				X
Trailer Lights	Check to be sure all lights are working.	Test before every use			
Trailer Wiring	Inspect wiring for bare spots, fray, etc. Grease all connectors with dielectric grease.			X	
Breakaway System	Check battery charge and switch operation.	Test before every use			
Hub/Drum	Inspect for abnormal wear or scoring.				X
Wheel Bearings and Cups	Inspect for corrosion or wear. Clean and repack.			X	
Seals	Inspect for leakage. Replace if removed.				X
Springs	Inspect for wear, loss of height.			X	
Suspension Parts	Inspect for bending, loose fasteners and wear.				X
Suspension Bushing	Grease bushings		X		
Hangers	Inspect welds .				X
Wheels	Tighten to specified torque values.		X		
Wheel, Nuts and Bolts	Inspect for cracks, dents, or distortion.		X		
Tire Inflation Pressure	Inflate tires to mfg's specifications.	Monthly and before each use			
Tire Condition	Inspect for cuts, wear, bulging, etc.		X		
Hardware	Check torque on all hardware		X		
Door locks	lube cylinder and lock mechanism.		X		
Door hinge	Lube hinge with Break-Free CLP		X		
Jacks	Grease gears				X
Ball coupler	Inspect for play & adjust as necessary	Before every use			
Ball coupler	Grease hitch ball and coupler, lube pivot and sliding surfaces with oil.		X		
Hardware	Inspect and check for proper torque		X		
Rubber seals	Clean rubber seals. Apply rubber seal protectant such as 303 rubber Seal Protectant or Nextzett Gummi Pflege Stick		X		8



Installation Instructions

Scout Trailer Kit

Part#87400

WWW.SMITTYBILT.COM

Ball Coupler

***** NOTE: 2" ball coupler is for on-road use only****

Torque ball coupler to hitch mount tube bolts to 70 ft/lb.

To adjust the hitch latch on your trailer's coupler, you will want to adjust the nut at the bottom of the latch. This nut may be tightened or loosened depending on what you need for your coupler.

The ball needs to be fully secured in the coupler and unable to come off. However, there should be enough room for some play. The hitch ball needs to be able to move inside the coupler so that nothing binds up while you are towing. The trailer needs to be able to move and pivot while moving, so the ball should be secure, but not tight, in the coupler. It is easiest to adjust by using a hitch ball and inserting it into the coupler. Then lock the coupler and adjust. Move the hitch ball around to check for the right tension. Once again, it should be loose enough that it does not bind, but tight enough that it does not come out of the coupler. Make sure to properly grease the ball. Hitch ball grease is available commercially at most auto parts stores, however high pressure wheel bearing grease is acceptable. **Failure to properly keep the coupler and ball greased may cause catastrophic failure.** Periodically oil pivot points and sliding surfaces of the coupler with SAE 30wt. Motor oil.

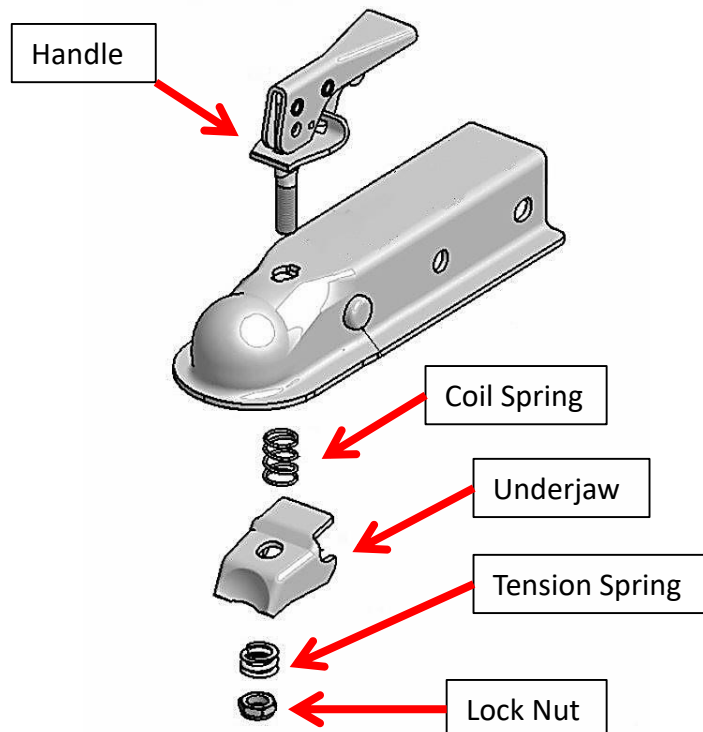



WWW.SMITTYBILT.COM

Installation Instructions
Scout Trailer Kit
Part#87400

Storage

- Fully inflate all tires. Cover the tires to protect them from UV rays. Place something between the tires and the ground. Make sure the base you use is larger than the actual footprint of the tire. If possible, store tires off the trailer during storage to prevent flat spots. If you do not remove the tires for long-term storage, periodically move the trailer to prevent flat spots.
- Chock the wheels front and rear. Leave the parking brake off. Angle the tongue downward to assist in snow and water run off.
- Store your trailer under a covered area if possible. If not, avoid parking under trees or in areas where grass and weeds will grow. If using a cover, be sure it is made of a breathable material. This will help in preventing mold and mildew.
- Wash the exterior of the trailer and clean interior thoroughly.
- Inspect all roof seams, body seams and door seals for cracks and openings. Make sure all seals are in place. Apply rubber seal protectant/conditioner such as 303 rubber seal protectant or Nextzett Gummi Pflege Stift. Replace seals if necessary.
- Service all locks with a graphite lubricant. Work key in and out after applying lubricant. Lube all hinges with Break-Free CLP or other high grade lubricant.
- Leave doors open if possible. If not possible, remove all items from interior, make sure interior is completely dry. Use desiccant such as OmniDry, Damprid, silica gel or other desiccant product. Many RV dealers will sell a desiccant kit. Use one in each cabinet and one in the tongue box. Always replace or reactivate desiccant at least every six (6) months. We recommend using 1 lb silica gel desiccant packages. Some desiccants may be reactivated while others need to be replaced, both are effective in fighting moisture, while those that can be reactivated (silica gel based) are more cost effective in the long term. It is recommended to place a dryer sheet in each cabinet. This will help reduce any odors and also helps repel rodents.
- Lube all zerk fittings with lithium /silicon based grease. Do not use any petroleum based grease or graphite.
- Lube hitch coupler with hitch ball grease and lube all pivots and sliding points on the couple with SAE 30wt. Motor oil .
- Lubricate all electrical contacts with dielectric grease.



WWW.SMITTYBILT.COM

Installation Instructions
Scout Trailer Kit
Part#87400

Cleaning

- Wash trailer with warm water and normal car wash soap after each use.
- Do not use any waxes that contain carnauba, abrasives or waxes that require polishing/buffing of a white or other solid residue. The residue will not come off of the fine textured finish. This type of wax is commonly used at car wash facilities. Use only power coat safe cleaning products. Do not use any petroleum based products. 303 Speed detailer or Lucas slick mist works well and provides a UV resistant coating.
- Do not use high pressure spray washers to wash trailer. Damage to seals, suspension bushings, finish and tires may occur. Hand wash only under low pressure water.
- Use only power coat safe cleaning products. Do not use any petroleum based products.
- Touch up any damaged paint areas. For larger areas, most commercially available satin black aerosol paint will work. Always test a small inconspicuous area for color matching. Sherwin-Williams satin black is a good match.
- Undercoating can be touched up using any commercially available undercoating spray. Many can be used directly over damaged /raw/rusty metal. Undercoating may stain from some types of soil/road chemicals and should be cleaned as soon as possible when encountered. Touch up if necessary. **Note:** some undercoating's may remain tacky, sticky or has an oily finish after applied and cured. Test a small area or scrap piece of metal for final finish before coating trailer to ensure you are happy with the coating.



WWW.SMITTYBILT.COM

Installation Instructions
Scout Trailer Kit
Part#87400

Wheel Bearings

Carefully remove the wheel hub's dust cap with a chisel and hammer. This will expose the castle nut.

Remove cotter pin, then remove castle nut. DO NOT reuse cotter pin, always use a new cotter pin for re-assembly.

Gently spin the hub to help you remove the drum assembly. Take note of orientation of seals, washers and bearings. If the hub is stuck you may need to use a mallet to tap the back side of the hub in a few spots. If the bearing is frozen to the spindle, you will need to knock off the hub with some force. If this happens, you may have to work off the frozen bearing by using a chisel to break it loose. Take care to not damage the spindle. If the spindle has any damage, replace spindle.

Remove outer bearing, then remove inner bearing by placing hub on a piece of wood, use a 1" wooden dowel that will fit into the center of the hub. Use a mallet to knock inner bearing out of hub, do this in a circular motion. The inner seal will be pushed out at the same time.

Inspect bearings, seals, race and spindle. Look for any nicks or discoloration. Replace if necessary. Remove all old grease from bearings before re-packing bearings.

Replace parts in the same order in which you removed them. Apply a small amount of grease to the castle nut. Final Castle Nut Adjustment:

To make sure the hub is seated properly, back off the castle nut until it is loose. Then tighten the castle nut snugly until it stops. Look to see where the cotter pin hole lines up with one of the notches on the nut. On hubs that use the tang washer or cage to lock the nut, you will have to do this by sight. Then back the nut off one notch, so that the cotter pin will fit through the castle nut.

Install the cotter pin and then spin and rock the hub. When you rock the hub you should feel the hub barely moving front to back. Try experimenting by loosening the castle nut one more notch to feel the difference in the play in the hub. Then install the wheel and rock the hub again. On the outside edge of the tire, the movement should not be more than 1/4" inch. Any play should be barely noticeable. When you are satisfied with the adjustment, secure the cotter pin. Push the pin through the hole on the end of the spindle and through the notches on the nut. Then split the bottom of the pin to the left and right.

Re-install dust cover using a mallet. If using a bearing buddy or bearing protector unit, follow manufacturer's instructions.



Installation Instructions

Scout Trailer Kit

Part#87400

WWW.SMITYBILT.COM

Assembly

Note: Even though the trailer kit uses lock washers, threadlocker is required on all hardware as an extra step to prevent hardware from loosening. Assemble pieces with all hardware before tightening hardware. Wicking (green) Loctite can be applied after hardware is tightened.

Before taking/ signing for the delivery of trailer kit, do a quick inspection for damage. Note all damage and notify shipper if any. Smittybilt does not cover shipping damage under the warranty.

Uncrating and assembly can be done with two people, 2-3 floor jacks, 4 jack stands, 2 - 4"x4" pieces of wood about 12"-16" long (to protect trailer from jack) you may want to use a 6' piece of 4x4 (optional but makes it much easier to support the front), a metric tool kit (sockets, wrenches, allen keys, etc.), various screwdrivers and an electrical tool kit. Tools required may vary due to product improvements. Use of lifting equipment will aid in the uncrating and assembly.



Fig 1



Fig 2

1. If equipped, remove the tires and wheels from the outside of the crate, then unbolt tire mounting brackets from crate. This will make it easier to maneuver around the crate during unpacking and assembly. Fig 1.
2. Remove the top halo of the crate by tapping it up evenly till the post are removed from the main crate. This must be done evenly to prevent the legs from binding and becoming difficult to remove. Remove tent if purchased and/or packed with the trailer kit. There may be bolts securing the top halo to the uprights. If so remove bolts. Then remove the removable upright.
3. Carefully remove shrink wrap. Take care to not scratch the trailer when unwrapping.
4. Remove contents of the main compartment. Unpack and lay out all pieces for easy assembly. Take inventory of all parts.



Installation Instructions

Scout Trailer Kit

Part#87400

WWW.SMITTYBILT.COM

5. Using jacks and 6' 4x4, support the front end of the trailer. Once supported, remove the supports that attach the trailer body to the crate. Fig 3. Support front of trailer with jack stands. You will position the 4x4 right behind the side tire mount. Support the rear of the trailer. Position jacks so they are on the outside of the crate. Lift trailer body slightly to take load off the mounting bolts. Then remove the mounting bolts securing the trailer to the crate. Then remove rear mounting brackets. Unbolt tongue from crate and carefully remove from crate. **Take care to avoid damaging parking brake and trailer wiring.** Now that the trailer is detached from the crate, slide the crate away from the trailer. You will have to re-position the front jacks to completely remove the trailer body from the crate. Once the crate is removed, use 4 jack stands to support the trailer body.



Fig 3

6. Remove hardware kit from side door.

7. Loosely attach tongue to trailing arm bracket using M16 bolts, flat washers, lock washers and nuts. Do not tighten hardware at this time. hardware. Fig 5.

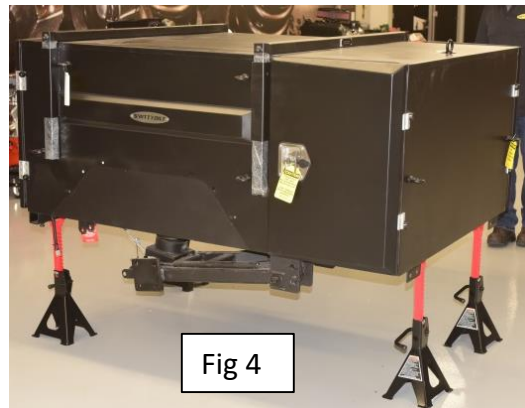

Fig 4

8. Attach jockey wheel mount to the tongue using M12 hardware. Once all hardware is in place, use thread locker and torque to 78 ft/lb. Fig 6. you may also use one of the shorter rear jacks to help lift the tongue.

9. Have helper lift up on the tongue, while tongue is raised put the jockey wheel on the mount and secure with pull pin so you can use the jockey wheel to lift the tongue into place.

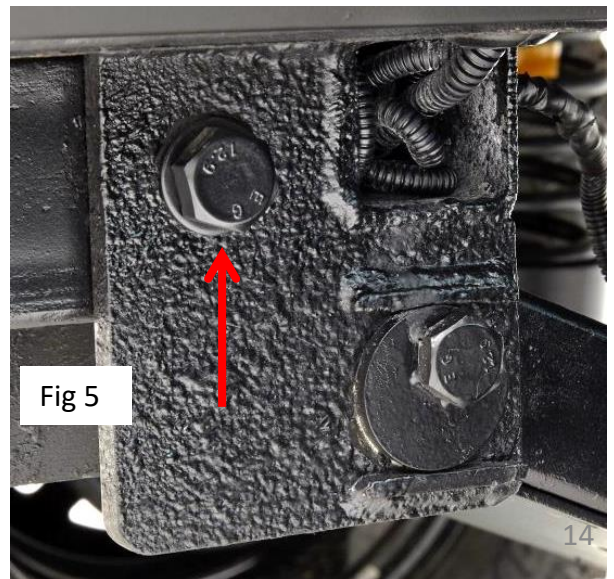

Fig 5



Installation Instructions

Scout Trailer Kit

Part#87400

WWW.SMITTYBILT.COM

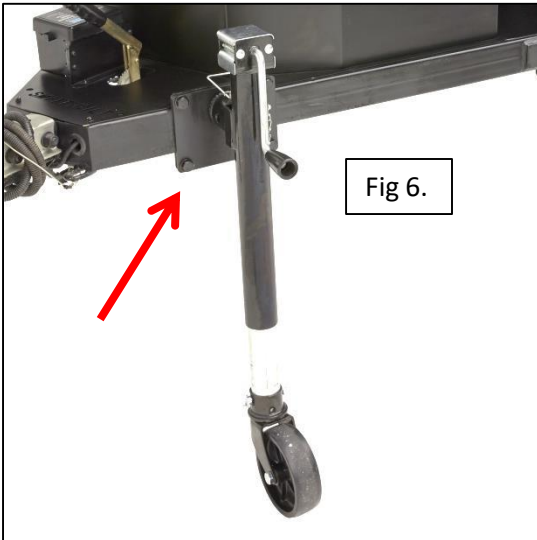

10. While tongue is lifted into place, line up the tongue mounting brackets with the holes in the trailer body. Secure tongue to trailer body with M14 bolts (4 total, 2 per side), spacer plate, flat washers, lock washer and nut, use threadlocker on the threads. Then install the M16 bolt for the center tongue support to the main chassis bracket. Torque M14 hardware to 120 ft/lb. and M16 hardware to 165 ft/lb. You may fully tighten these bolts now. Fig 7a and 7b.

10. If your tongue has a tube welded inside the tongue where the M14 bolts pass thru, you will not need to use the spacer plate.

11. Tighten the tongue to trailing arm bracket bolts that were installed in step 8, Torque these M16 bolts to 165 ft/lb. You will want to remove the nut and apply threadlocker to the threads before tightening. Fig 9

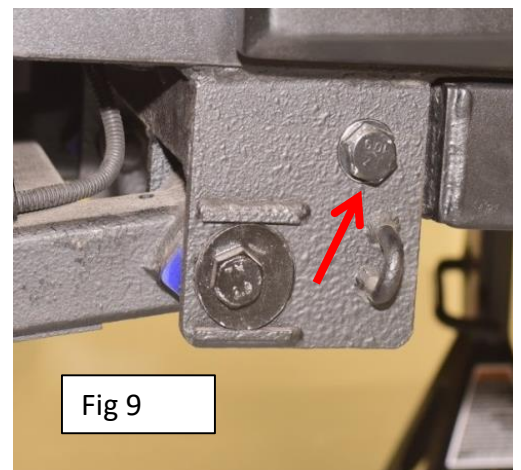
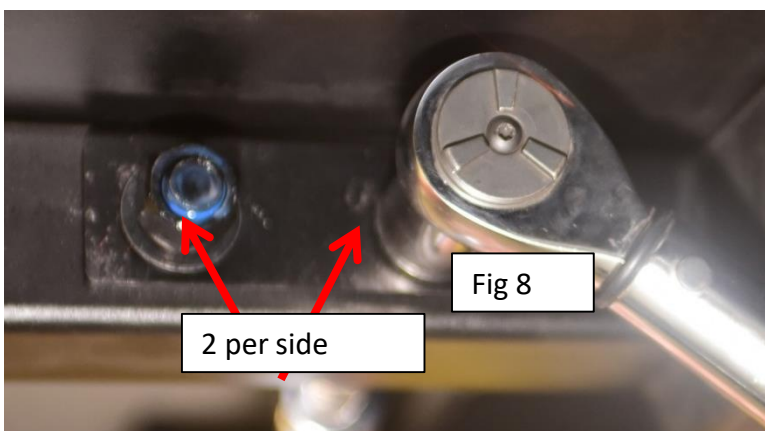
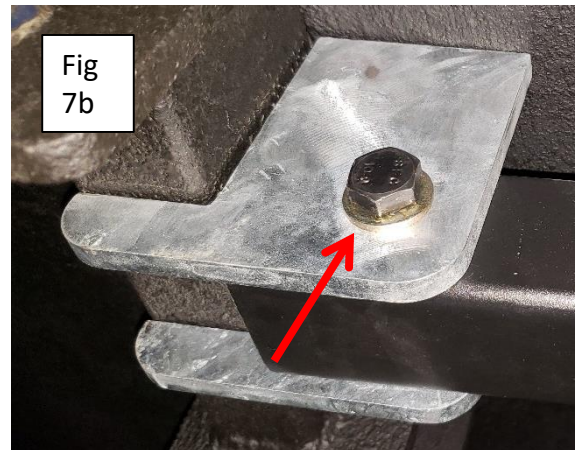



WWW.SMITTYBILT.COM

Installation Instructions

Scout Trailer Kit

Part#87400

14. Install rear stabilizer jack mounts and jacks. When using stabilizer jacks make sure to install the pull pin, secure with hair pin and tighten the jam bolt. Fig 10. Remove jacks when added clearance is needed. Use jacks to help stabilize trailer. Always deploy jacks before unloading trailer.

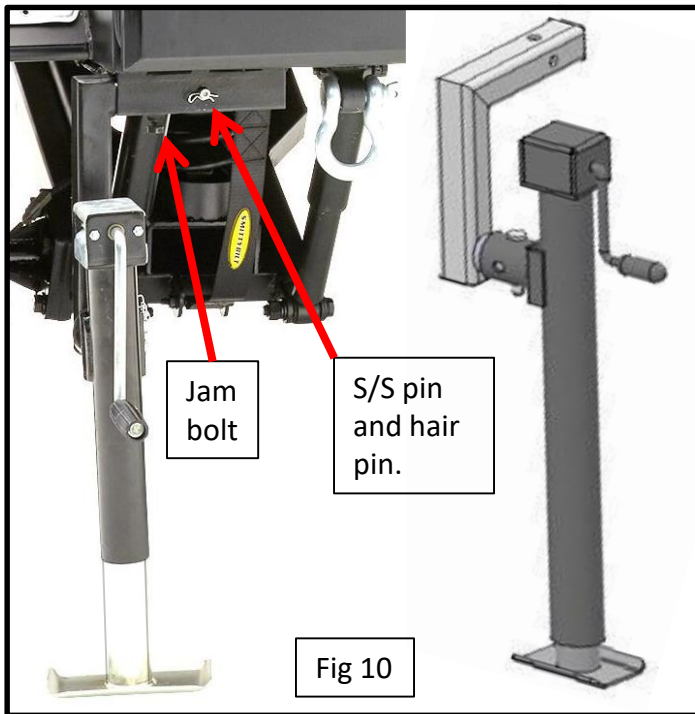

15. Use a jack below the trailing arm, raise trailing arm slightly to take pressure of the straps holding up the arm. Lower suspension arm to allow for easier access to bump stop mounts. Secure long bump stop to the upper spring cup using M10 hardware. Secure short bump stop to lower spring cup using M10 hardware. Use threadlocker on bolt, you may fully tighten the bump stop hardware to 30 ft/lb. Fig 11.



16. Install coil spring isolators inside of each spring cup, making sure they are completely and evenly seated. The coil spring will help making them sit even.



WWW.SMITTYBILT.COM

Installation Instructions

Scout Trailer Kit

Part#87400

Pro tip:

In the following steps you will be assembling the suspension. If installing large tires, you may want to temporarily install the tires and wheels before the spring so you can cycle the suspension easier. Once tires and wheels are installed, compress the suspension till it hits the bump stops. Then hold up the fenders to the side of the trailer body lining up the existing fender mounting holes. Check for tire clearance, you want a few inches of clearance around the tire to the fender. If needed, raise the fender, make sure its level and use the fenders mounting holes as a template and mark new fender mounting holes. If raising the fender make sure you raise it high enough so you can plug the existing mounting holes with a bolt or use a silicon sealer. It is recommended to use a bolt with silicon sealer to plug the holes. Make sure to check fender to side door clearance. Generally, you can fit most 37" tires with the fender mounted in the pre-drilled holes. Remember the suspension will travel almost straight up and down. If raising the fender you may have to extend the taillight wiring. In most cases you can fit up to a 37" tire with the fenders in the lowest position.

Install fenders using M10 hardware. Use thread locker on hardware and torque to 28 ft/lb. The sandwich plate goes on the inside of the trailer. You will insert the button head bolts from the inside to the outside. This gives the interior smoother walls and the sandwich plate provides added strength. **Do not use the fenders as steps.** **The bottom most forward and rear fender mounting bolts can be installed from the outside inward.**

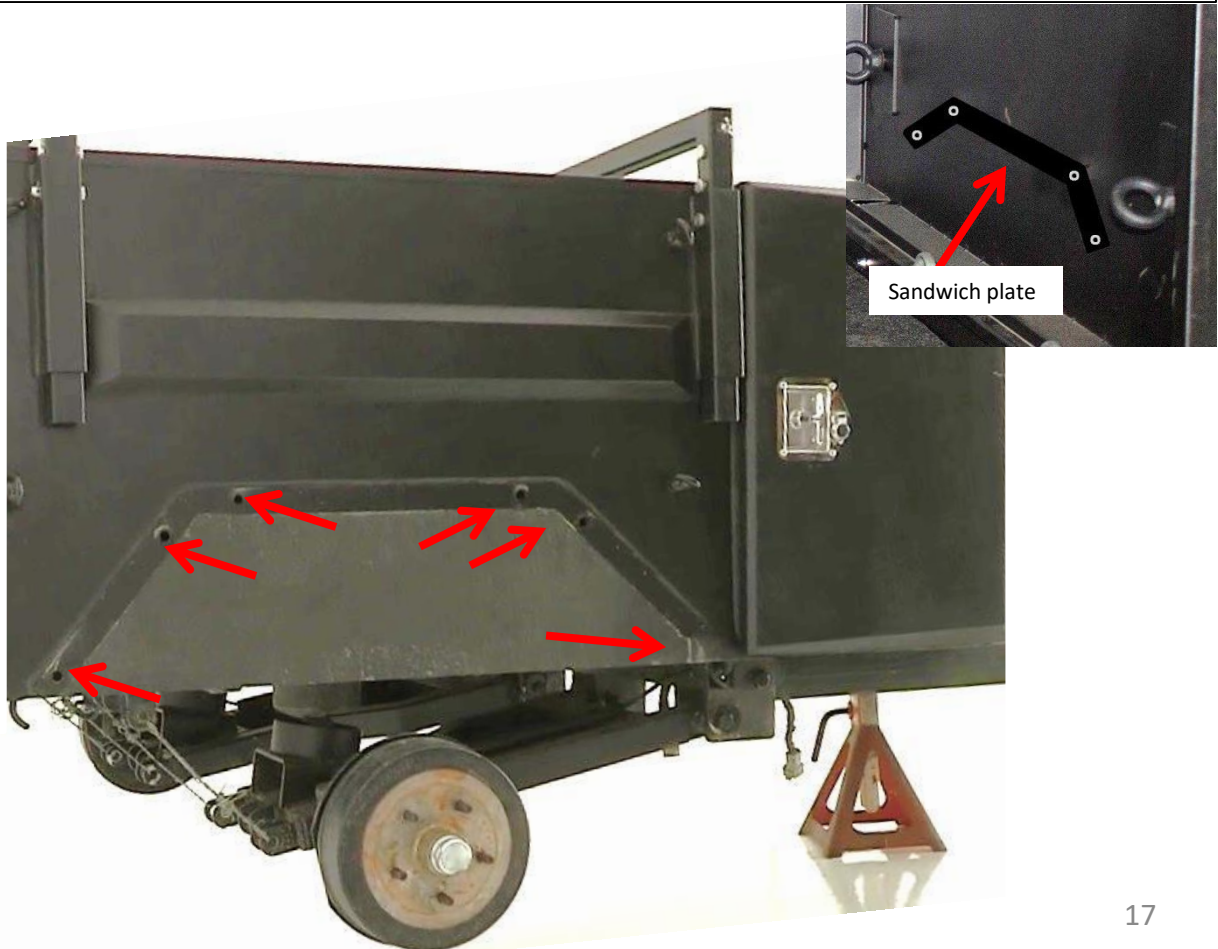



WWW.SMITTYBILT.COM

Installation Instructions

Scout Trailer Kit

Part#87400

Wheel hub

Depending on production run you may have to assemble the wheel hub to the trailing arm.

1. Note orientation of brake lever. This should pull towards the front of the trailer and be towards the top of the axle. Brake hub may be labeled left or right.
2. Attach wheel hub to trailing arm using M16x60mm hex head bolt, M16 flat washers, M16 lock washer and M16 nut. Use thread locker. Install all 4 bolts before tightening the bolts. Tighten bolts in a star pattern. **Once all 4 bolts are in place torque bolts to 165 Ft/lb.** Connect brake wire plug to the socket on the trailing arm. You want to use dielectric grease on the pins. Zip tie wiring to prevent it from hanging.

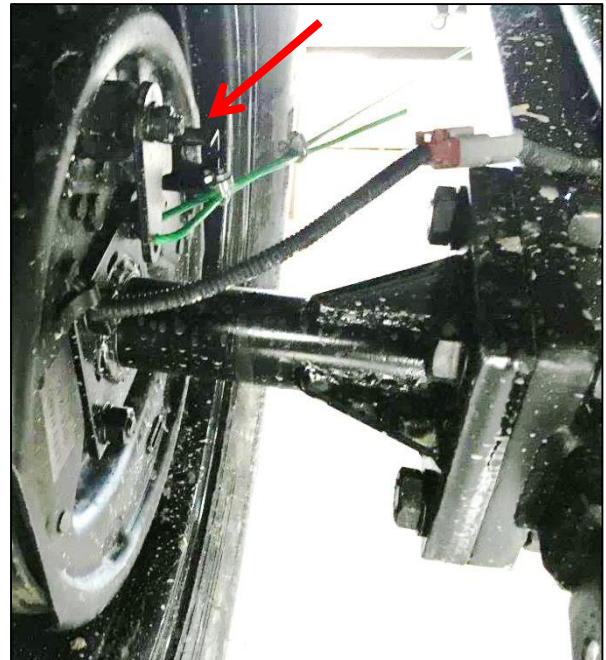



WWW.SMITYBILT.COM

Installation Instructions

Scout Trailer Kit

Part#87400

17. Install coil spring. Use jack to compress suspension once the spring is installed into the cup, as you raise the suspension be sure to line up the spring with the cups. Fig 12. Make sure coil is seated inside the rubber isolator evenly.

18. Install limit strap into middle mounts on trailing arm and trailer body. Use M10 hardware. Its easiest to put the limit strap into position, then insert bolt into mount. The bolt will go in at a slight angle when first started, then will straighten out when going thru the second mount. Apply thread locker to threads and tighten to 25 ft/lbs. Take care to not over tighten. Fig 13.

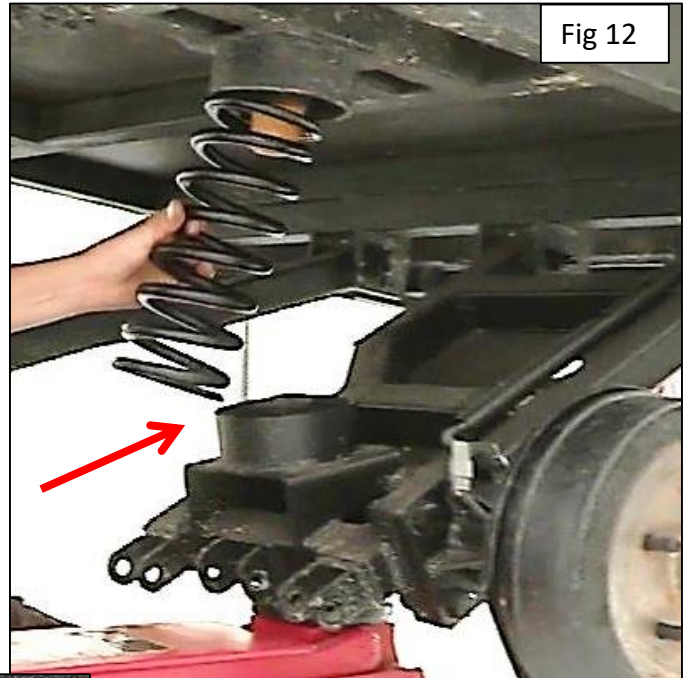

Fig 12

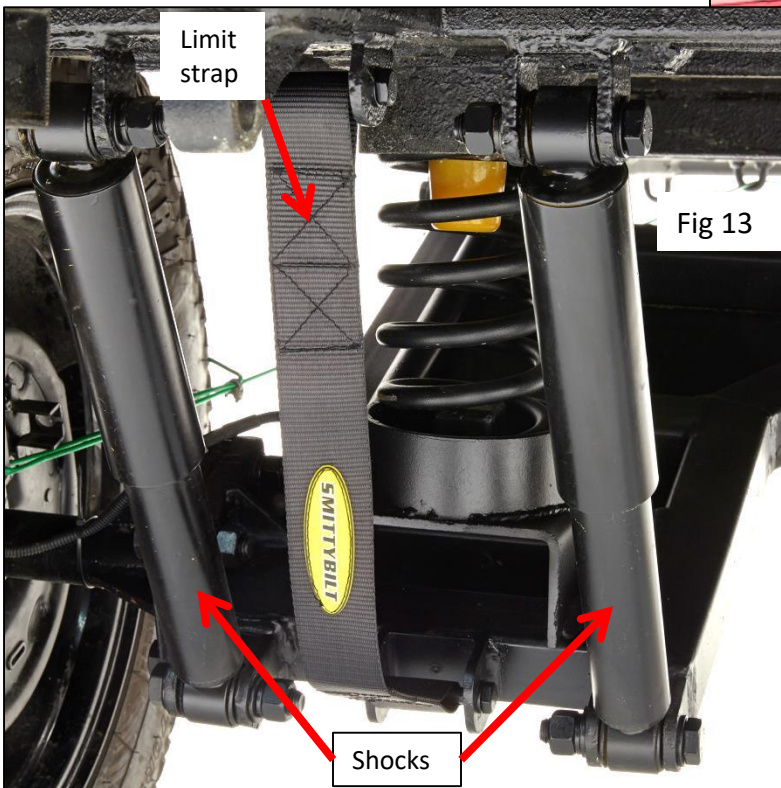

Fig 13

19. Install shocks into the outer mounts on the trailer arm and trailer body. Use M16 hardware to attach them. Do not tighten this hardware till you have the full weight of the trailer supported on the suspension. Its best to tighten after the tires and wheels have been installed and are supporting the trailer. If shocks are tightened without weight of trailer on suspension you will bind the bushings which may cause squeaking and will accelerate wear on the bushings. Lube bushings and the area in which bushings make contact with trailer body and trailing arm mounts with lithium based grease. Apply thread locker to threads. Fig 13. You will torque these bolts to 85 ft/lb.



Installation Instructions

Scout Trailer Kit

Part#87400

20. Install tires and wheels on to axles. Make sure center caps are inside of the wheels before installing. (only if wheels use push thru cap) you may want to apply anti-seize to the wheel mounting surface to help prevent corrosion and will make the wheel easier to remove when rotating tires, you may also apply a small amount of anti-seize to the lug studs. The trailer kit comes with 60° conical seat lug nuts, make sure your wheels have a compatible seat. Make sure lug nuts have at least ½" of thread engagement. Tighten the lug nuts in a star pattern. Make sure to properly torque the wheels. Then re-torque after the first 25 miles and then each 50 miles till they hold their torque. Always check wheel manufactures torque recommendations/specifications. Do not exceed 95 ft. lb. Lower torque ratings when using anti-seize on the threads, generally about 25% less torque is required when using anti-seize. Generally ½" lug nuts need to be torqued to 85-95 ft. lb. Fig 14.

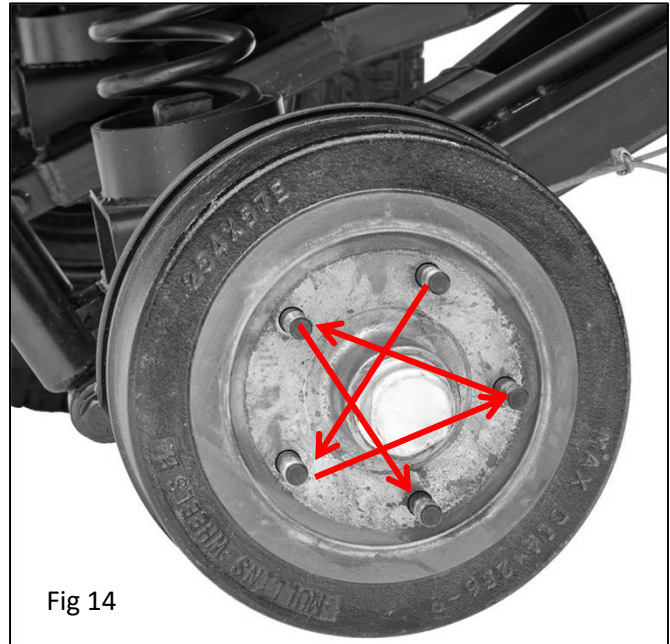

21. Install all eyebolts. They may be installed in any clocking position but we have found the best is a vertical orientation. Seal all eyebolts with black silicon sealant to prevent ingress of dust/water. Each eyebolt assembly consists of a male and female eyelet, one side will be on the outside of the trailer and the other will be on the inside. On the roof of the trailer in the front near the spare tire you will use a male eyebolt only. It will thread into the threaded hole. This eyebolt can be used to tie down the spare tire. Fig 15.

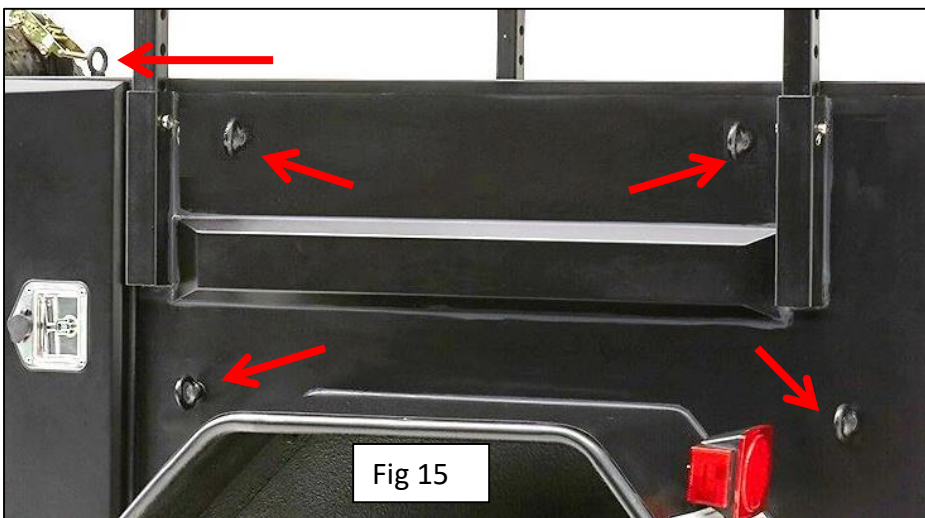



Installation Instructions

Scout Trailer Kit

Part#87400

WWW.SMITTYBILT.COM

22. Install spare tire mount onto tongue. Install all M10 bolts before tightening, use flat washers and lock washers. The large washer will be used on the underside of the tongue. Opening will face towards the passenger side of the trailer. Install spare tire into tire mount and secure with tire tie downs. There are two tire tie down straps, one around the circumference and one over the top. Its easiest to install the over the top strap first. The over the top strap has three different tie down points, you will use the one on the front of the tire mount. In the rear(near trailer body) you may use the tie down point on the tire mount behind the tire or you may use the eyebolt on top of the trailer body. For large tires and sever off-road use it is recommended to use the eyebolt. There will be excess strap once straps are tightened. You may choose to trim excess. Take in consideration of possible bigger tires in the future will need a longer strap, cut accordingly. Make sure to seal the ends of the strap using a flame, this will prevent fraying of the strap. Fig 16-21 torque these bolts to 25 ft/lb.

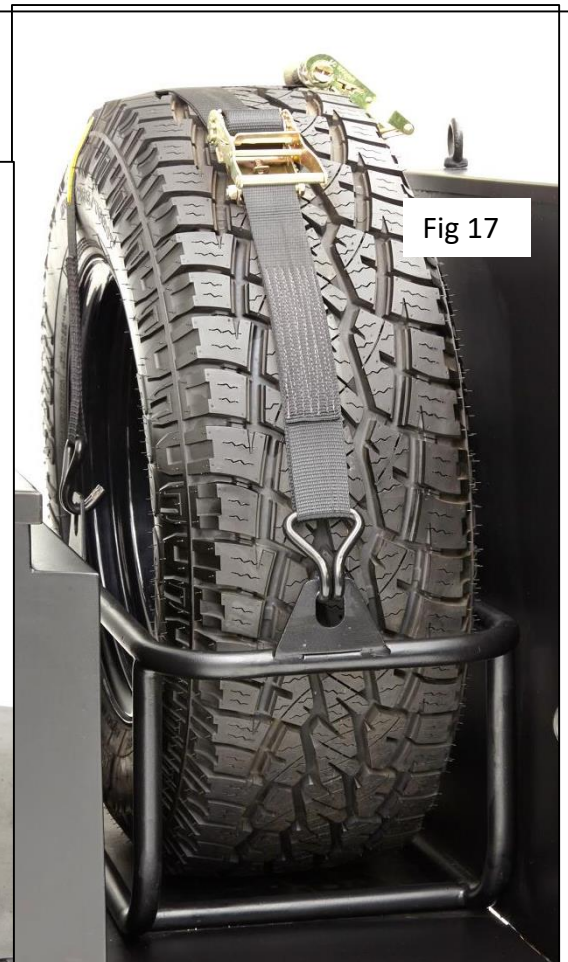



Installation Instructions

Scout Trailer Kit

Part#87400

WWW.SMITTYBILT.COM

Fig 18

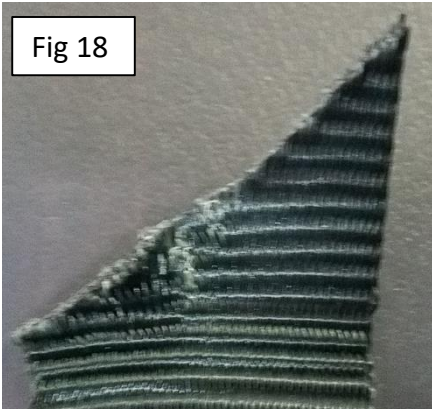

Fig 19

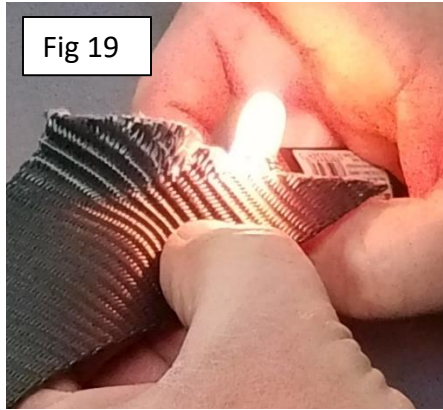

Fig 20



Fig 18 shows unfinished strap cut. You may cut the strap at an angle to aid in threading it into the ratchet mechanism, or you may cut it straight across. Fig 19 shows sealing the end of the strap with a flame. Fig 20 shows finished sealed strap. When tightening ratchet always make sure to lock ratchet mechanism in the fully closed lock position. Fig 21



Fig 21



Installation Instructions

Scout Trailer Kit

Part#87400

WWW.SMITTYBILT.COM

23. Install tongue box onto the tongue by lining up the mounting holes in the box with the holes on the tongue. Use M10 bolts , flat washer, large washer, lock washer and nut to secure to tongue. Make sure all bolts are in place before tightening hardware. Torque to 25 ft/lb. If not installing tongue box, install tongue box bolts to the tongue as they help secure the tongue cover plate. Fig 22 shows tongue box mounted. Fig 23 shows bottom side of trailer tongue and the tongue box hardware. While under the tongue check torque on the pre-installed parking brake lever.

Fig 22

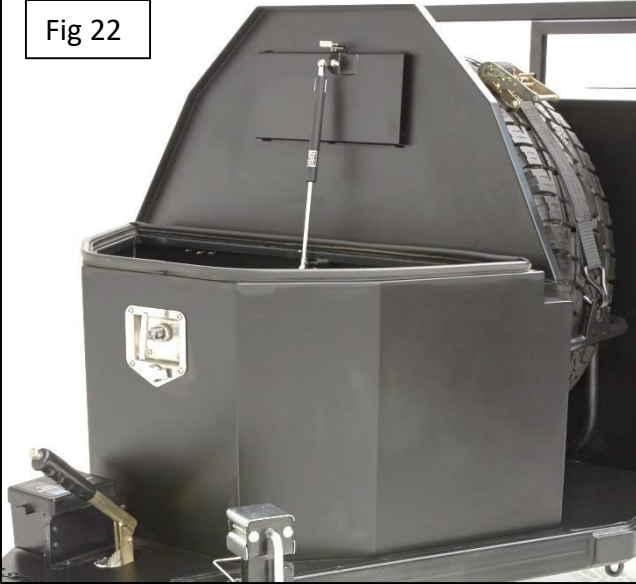
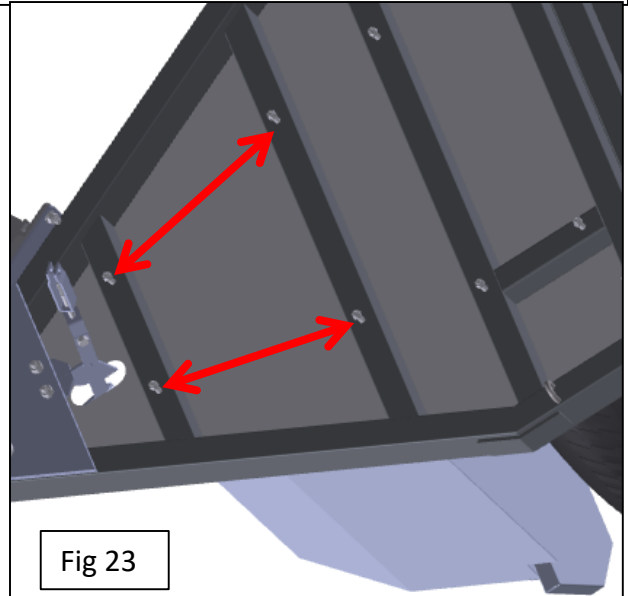
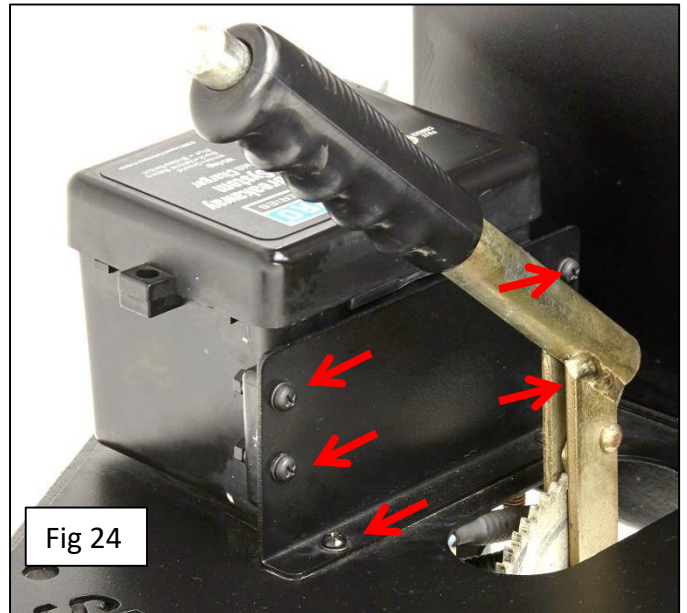

Fig 23



24. Install break away brake system. First mount the box mounting bracket to the tongue. Use M6 hardware. It may be easier to remove the tongue plate to access the hardware, then re-install tongue plate. Second, attach break away box to the bracket. You will want to run the wires thru the tongue plate before bolting the box to the bracket. Wire the brake away system into trailer wiring according to the instructions that are included with the break away system. Use the supplied deutsch connector. Fig 24. Leave tether switch loose till step 30.

Fig 24





Installation Instructions

Scout Trailer Kit

Part#87400

WWW.SMITTYBILT.COM

24. Continued. To install deutsch connector. First strip the wire approximately 3/16". Second, position terminal on the wire, you will see that there are two sections that will be crimped, one around the seal and one around the bare wire, you may need to strip more insulation or trim wire to make sure terminal is correctly positioned. Crimp on the terminal. This can be done with a special crimping tool, but can also be done carefully with pliers. If using only pliers, we recommend putting a dab of solder to ensure the wire will not pull out easily. Insert the seal into the connector body. Once the terminal is crimped on, insert it into the connector body, you will feel a "click" when the terminal is inserted into the terminal body, a slight tug will confirm that it is properly locked in place. Make sure all wires are correctly oriented in each plug, white to white, black to red, and blue to blue. On the male pins, once all the pins are in their proper place, install the female wedgelock to secure the pins in the terminal. On the female pins, you will use the male wedgelock to secure the pins. SEE PHOTO ON PAGE 25.

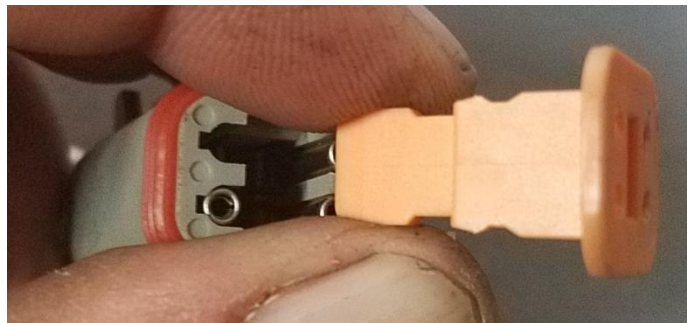
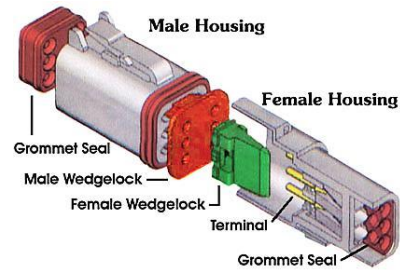
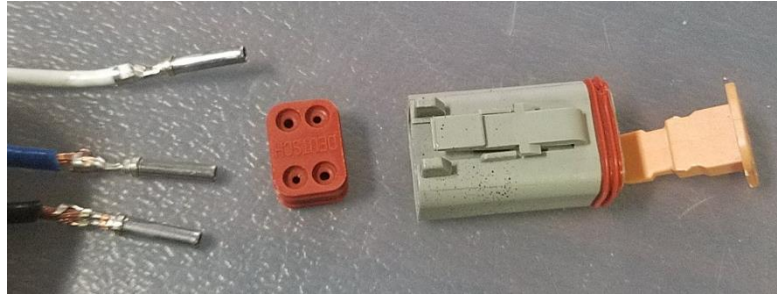



WWW.SMITTYBILT.COM

Installation Instructions
Scout Trailer Kit
Part#87400



From
breakaway
system

To 7 pin
socket

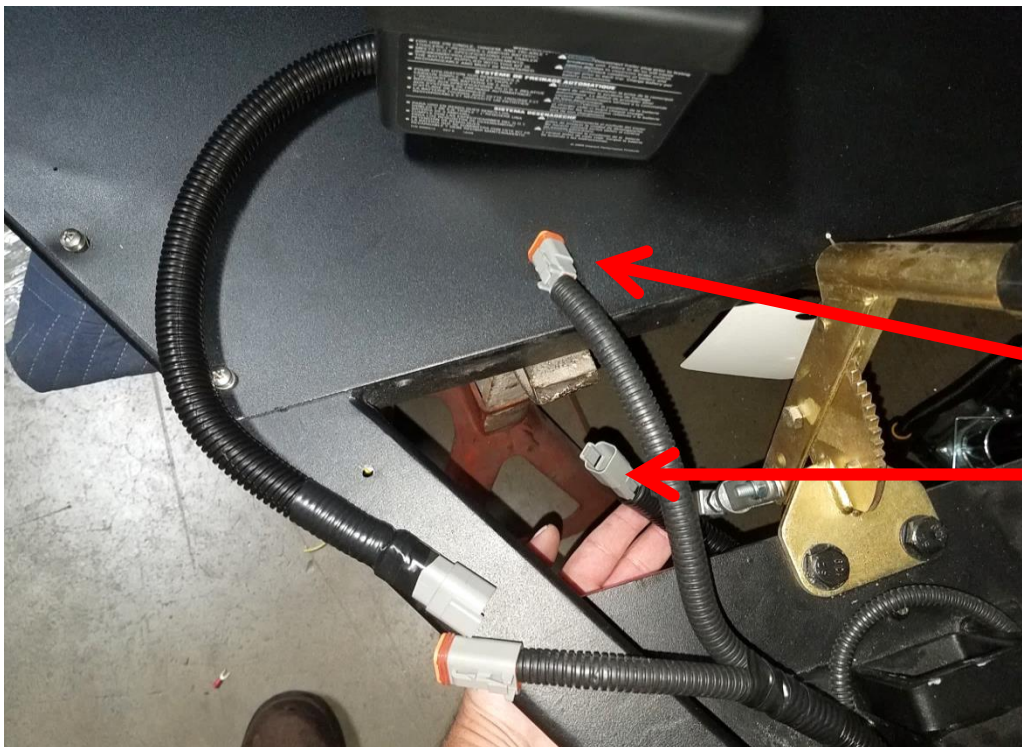

Parking
brake cover
plate
removed
for photos.

From 7 pin
to break
away
tether.



WWW.SMITTYBILT.COM

Installation Instructions

Scout Trailer Kit

Part#87400

25. Install tent mounting bars, they need to be inserted into the mounts simultaneously, and secured with stainless steel pin and hair pin. Insert the stainless steel pin with a spacer on the head from the rear to the front. This allows for clearance between the pin and the side doors of the trailer. Fig 25. Choose a height that will best suit your needs. Take in consideration the height of the tent or other object you mount onto the rack. These become difficult to adjust once the tent has been mounted. Do not use a jack to adjust, as damage to the trailer body may occur. It is recommended to remove any objects mounted to the rack before adjusting height.

26. Install awning mounts if desired. Secure with stainless steel pins and hair pins. Install threaded knob into the threaded hole on the tent mounting bar. The knob will take up any slack in the mounts. Knob must be completely loosened when adjusting awning mounts. To use awning with the tent open, raise and extend the awning mounts completely. To stow awning, raise mounts so the horizontal mount will fit over tent, then collapse the horizontal mount inward. Fig 26, 27 &28

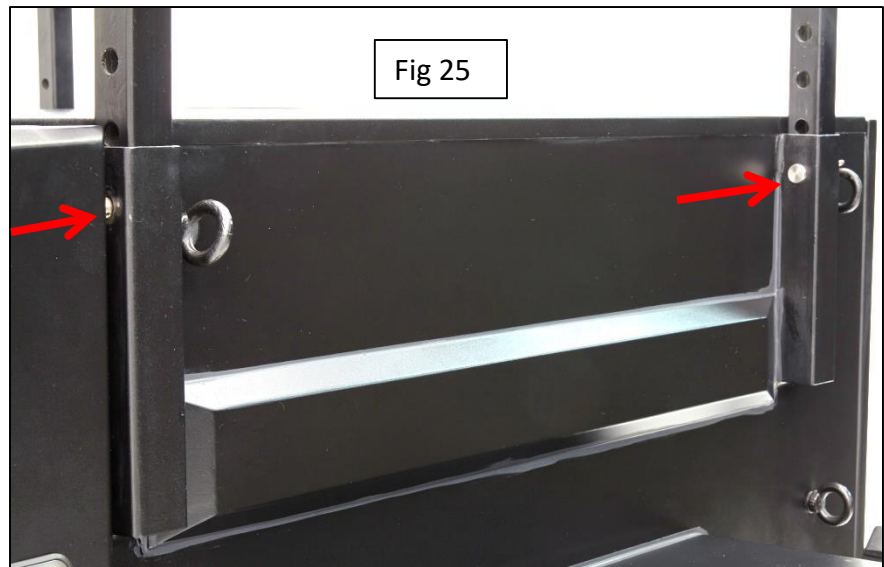



WWW.SMITTYBILT.COM

Installation Instructions Scout Trailer Kit Part#87400

27. Install awning onto the horizontal awning mount. Use hardware that is included in your awning kit and mount per awning instructions. There are 4 holes in the awning mount, only 2 need to be attached for most awnings. Make sure threaded knobs are loose when mounting or adjusting awning.

28. Install tent if desired. Follow tent mounting instructions that are included with your tent. We have included four "U brackets" that can be used for tent mounting. They will cradle the bottom of the tent mount. When mounting the tent and if an awning is used, make sure you have enough clearance between the tent and the awning mounts. This will offset the tent to one side of the trailer, leave at least 1.5" of clearance between tent and awning mount so you have enough room to fasten the tent cover. Fig 29. Observe the direction of the tent opening when mounting tent. We have found that positioning the rear of the tent level with the rear door of the trailer box gives the best results and balance, however each trailer setup may be different and tent position should be adjusted accordingly. Make sure your tent opens to the opposite side of the awning. Some like the awning over the kitchen drawer with the tent opening up over the generator drawer. If you have the tent opening up over the kitchen, it is recommended to have the tent as far back on the tent mounts to provide head room when using kitchen, or have the tent mounts high enough up so you can walk under tent. Fig 29&30.

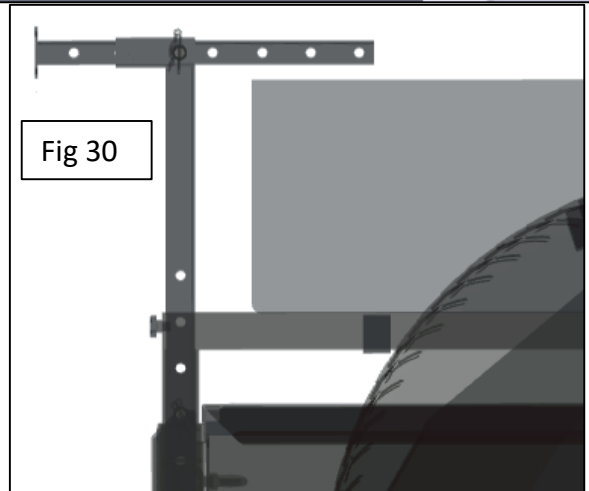
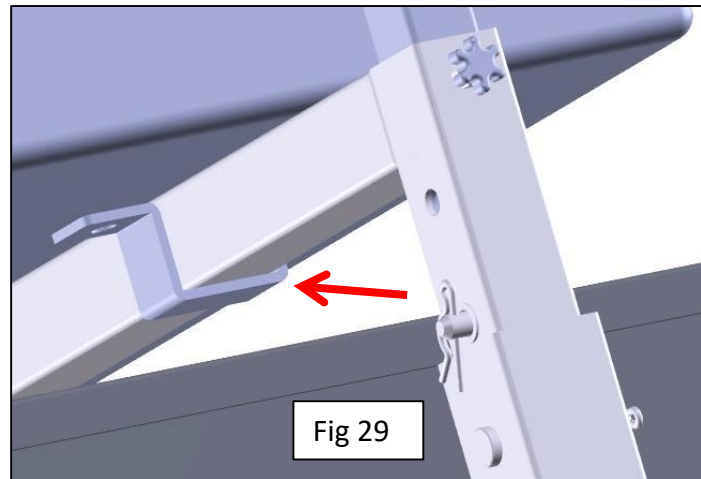
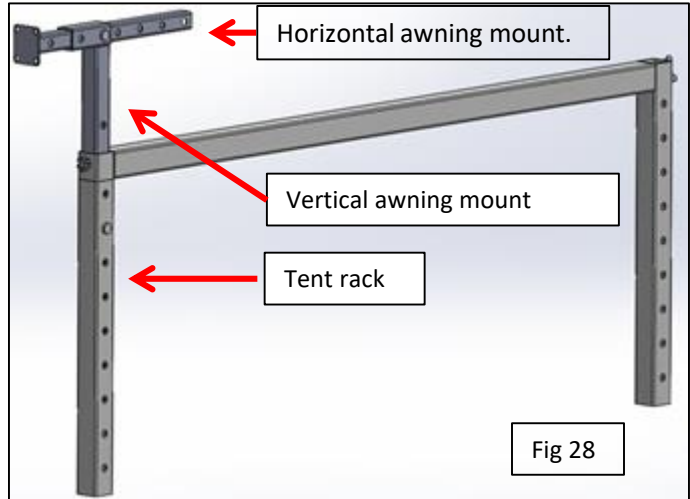



Installation Instructions

Scout Trailer Kit

Part#87400

WWW.SMITTYBILT.COM

29. Make sure parking brake lever is down all the way and adjustment screw is loosened. You will want the adjustment screw to be able to mostly tighten the cable while still having some adjustability to loosen the cable. Make sure adjustment mechanism can move freely on parking brake attachment. Route parking brake cable thru the guides in the tongue and the frame, keeping the cables as high as possible. End of cable will go thru the loop on the brake actuator arm on the brake drum, then it will loop back on itself. Pull the cable as tight as possible and secure with wire rope clips. The U-bolt side will go on the dead end of the clip and the saddle will go on the live end. Fig 31, Green line indicates where the brake cable will lay. Fig 32 shows correct orientation of the u-bolt and saddle. It is easiest to secure one side then remove slack and secure the opposite side. Use adjuster to take excess slack out of brake line and lock up the brakes when the handle is about 3-4 clicks from the last slot

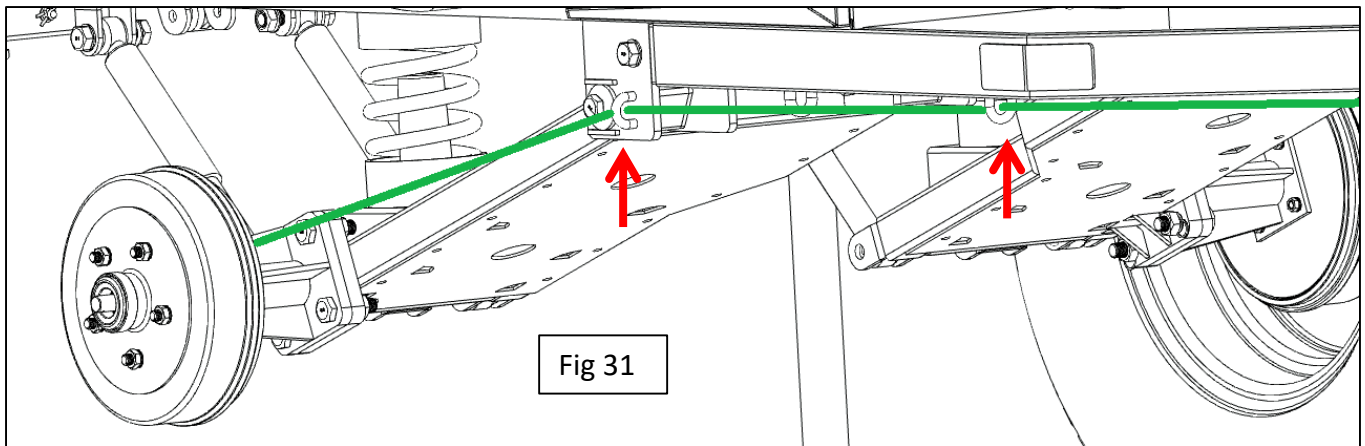

U-bolt of all clips on dead end of the rope. Fig 32.

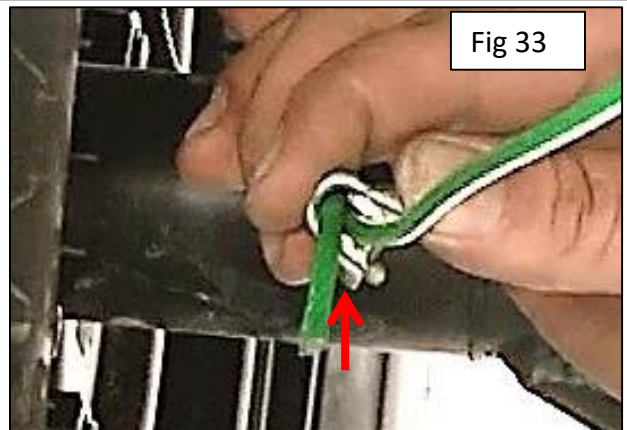



Installation Instructions

Scout Trailer Kit

Part#87400

WWW.SMITTYBILT.COM

30. Install break away system tether switch to the underside of the tongue using a bolt , washers and nylock nut. Do not over tighten, as the switch must be able to pivot on the bolt. Location will vary depending on type of coupler being used. Mount into a position where the lanyard does not interfere with any object and has the straightest pull possible. We have supplied a mounting hole on the bottom of the tongue just in front of where the parking brake is mounted. Be sure lanyard does not contact the ground. Do not hook the lanyard to the safety chain loop or hitch ball, It is ideal to have it secured directly to the frame of the tow vehicle. You want the lanyard to be longer than the tow chains and must not bind when maneuvering the trailer. The theory is that you want your safety chains to be the first line of defense in case of a trailer separation, then you want the brakes to be applied only if the safety chains fail and you have a complete detachment of the trailer. It will need to have the deutsch connector installed and plugged into the tongue wiring in order to function properly Fig 34 & 35.



Fig 34

31. Attach coupler into the front 2" receiver and secure using 5/8" hitch pin. The 2" receiver will accept many aftermarket articulating style couplers (not included). The supplied ball coupler is for on-road use only due to its limited range of movement. Off-road use may cause detachment of the coupler from the ball. There are several articulating hitches on the market such as the Max coupler, lock-n-roll, pintle hooks etc. Choose which one suits your needs the best. We have had great success with the max coupler. Do not use any type of weight distribution hitch or load levelers, detachment from tow vehicle or damage may occur.

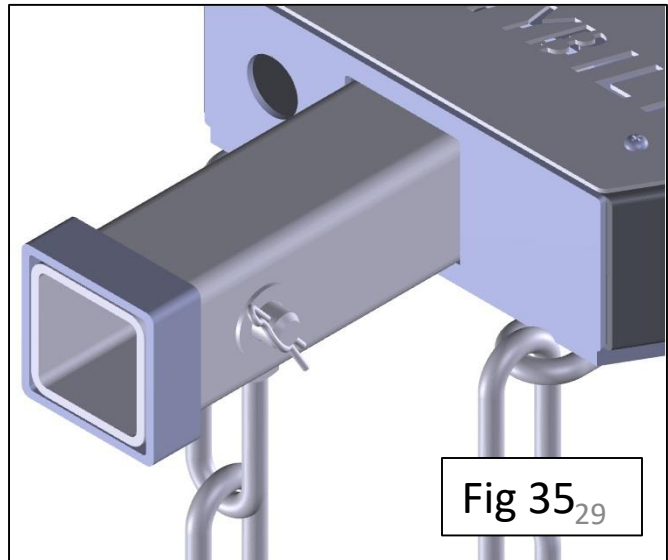

Fig 35₂₉



WWW.SMITYBILT.COM

Installation Instructions

Scout Trailer Kit

Part#87400

32. Attach stabilizer jack mounts to the rear of the trailer, secure with stainless steel pull pin and hair pin. Use the jam bolt at the bottom of the mount to take up slack of the jack mount. Always tighten jam bolt before using jacks. If more ground clearance or departure angle is needed, remove and store the jacks and jack mounts. Jacks will attach to the jack mounts using the pull pin that is attached to the jack. When using the jack it is best to install pull pin in a vertical orientation, as this will reduce the amount of teetering the jack will do on the jack mount. Even though the jacks feature a large footprint, when using the jacks on soft surfaces you may want to use some kind of jack base to prevent the jack from sinking. Use jacks to level the trailer using minimal lift heights. Excessive unevenness of the trailer should be leveled with wheel ramps which are available at most RV and trailer accessory shops. Always stow jacks before attempting to move trailer. If your Tongue Jack and stabilizer Jacks have to travel a long ways down it can stress them or damage them. To prevent damage you should pile up some jack pads or pieces of board to decrease the distance that your jacks have to travel. It is a good practice to always have at least one jack pad under each jack, so that the jacks do not sink into the ground or cause damage to the surface of the ground they are sitting on. Use your tongue jack for front to rear leveling. Fig 36 +37 shows in use position. Always deploy stabilizer jacks before unloading trailer or using a roof top tent. Maintain jacks by greasing the zerk fitting, then rotating jack handle to distribute grease. Grease your jack at least every year. Keep jack shaft clean.



Fig 36



Fig 37



WWW.SMITYBILT.COM

Installation Instructions
Scout Trailer Kit
Part#87400

33. Lube all zerk fittings with a lithium based grease. Zerk fittings are found on the trailing arms where they mount to the trailer frame. Each trailing arm has two zerk fittings. Always clean zerk fitting before attaching grease gun to fitting. White lithium grease is recommended. **DO NOT** use petroleum based grease as this will damage the bushings. Stay away from spray lube. When greasing bushings, pump in enough grease to push out old grease, keep filling till all the discolored old grease is removed. Fig 38.
34. Mount tail lights to fenders and connect quick connect fitting. Mount license plate on the driver side fender if a license plate is used. Fig 39.
35. Turn to page 51 for alignment instructions.
36. Apply wicking grade loc-tite/threadlocker (green) to all fasteners.

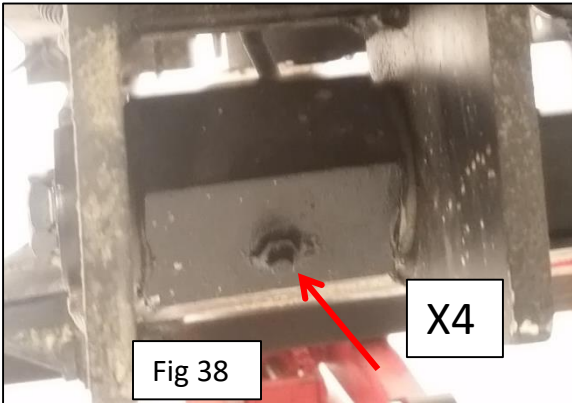



Installation Instructions

Scout Trailer Kit

Part#87400

WWW.SMITTYBILT.COM

Kitchen drawer:

- Remove carpet from slider if placing a stove or heating device on it.
- Extend drawer fully, then fold down drawer supports. Lock legs by tightening the wing bolts.
- Periodically clean and lube legs with Break-free CLP. Wipe off excessive oil.
- Extra space behind the drawer can be used to hold a basin, trash bag or other object.
- Make sure to stow legs before closing drawer.
- 100 lb capacity when support legs are engaged.
- Drawer side may be repositioned by unbolting it and moving to the other side.

Generator drawer:

- Extend drawer fully, then fold down drawer supports. Lock legs by tightening the wing bolt.
- It is recommended to remove generator from drawer when ran for extended periods of time or when food or other sensitive items are stored in the kitchen cabinet.
- Periodically clean and lube legs with Break-free CLP. Wipe off excessive oil.
- Make sure to stow legs before closing drawer.
- Slider features locking pin, make sure to engage pin when slider is stowed. Locking pin can be positioned to stay open. Make sure it is in the hold open position when operating slider.
- It is HIGHLY recommended if you choose to keep your generator in the drawer and run for long periods of time, that you re-route your exhaust system to an area below the trailer. Many generator exhaust systems can be extended with the use of high temp hose silicon hose couplers and small diameter tubing. There are also commercially made kits available. Check your local RV supply or generator supply. Do not disable the spark arrestor.
- 100 lb capacity when support legs are engaged.





WWW.SMITYBILT.COM

Installation Instructions

Scout Trailer Kit

Part#87400

Rear door:

- Sliders feature a hold open/ closed latch. Depress mechanism when operating slider.
- Slider features locking pin, make sure to engage pin when slider is stowed. Locking pin can be positioned to stay open. Make sure it is in the hold open position when operating slider.
- Always secure load to drawer.
- Use caution when operating slider as loads may have shifted during travel.
- Do not exceed 200 lb evenly distributed weight capacity.
- Keep sliders clean, re-grease if necessary. Use lithium or silicon based heavy grease.
- If hold open/closed latch fails to catch, it can be adjusted by slightly bending the locking tab upwards.





Installation Instructions
Scout Trailer Kit
Part#87400

WWW.SMITTYBILT.COM

Tongue Box BOM List

Component	Name	Qty	Secondary Component	Name	Qty
Work piece	Box lid	1			
	Box body	1			
	Large washer	4			
Standard Component	Hexagon head bolt M10*80	4			
	M10 flat washer	4			
	M10 lock washer	4			
	M10 nut	4			
Accessories	Air stay	1	Hardware	M8 nut	2
				M8 lock washer	2
				M8 flat washer	2
	T-lock	1	Hardware	M5*16 stainless steel bolt	4
				M5 flat washer	4
				M5 lock washer	4
				M5 nut	4
	Hinge	3	Hardware	M4*10 stainless steel bolt	18
				M4 flat washer	18
				M4 lock washer	18
M4 nut				18	
Seal	2.3m				

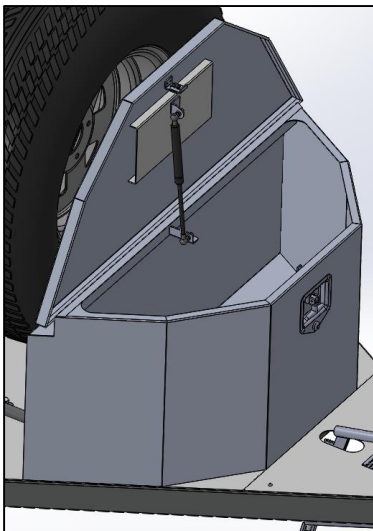

- Keep lock , T-handle, and locking arm clean and lubed.



WWW.SMITTYBILT.COM

Installation Instructions
Scout Trailer Kit
Part#87400

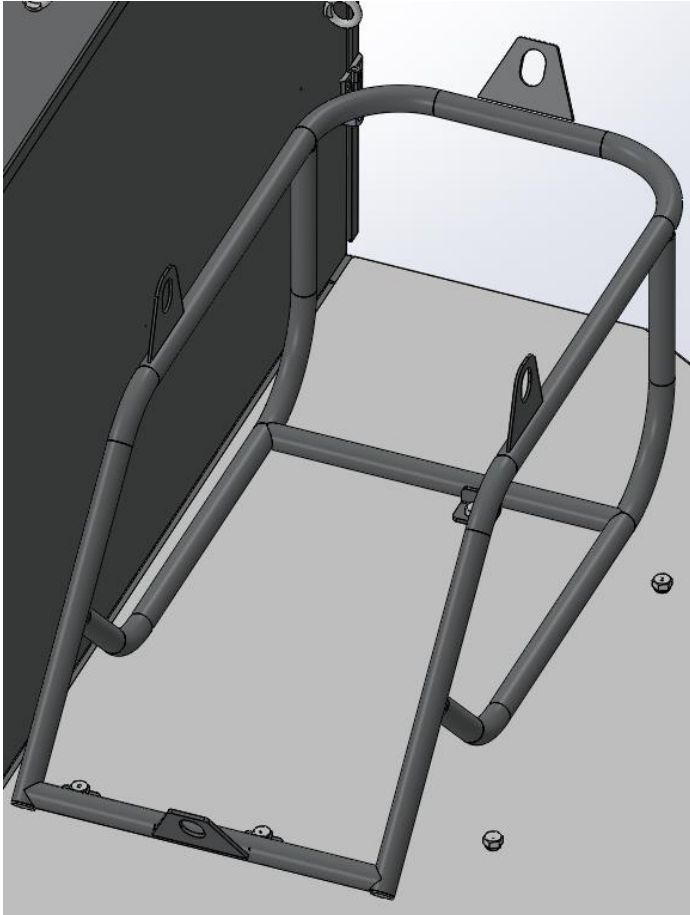

Tire Rack BOM List

Component	Name	Qty
Work piece	Rack body	1
Standard Component	M10*80 bolt	3
	Large washer	3
	M10 flat washer	3
	M10 lock washer	3
	M10 nut	3
Accessories	Spare tire strap	2

- Keep ratcheting mechanism clean and lubed.
- Use Break-Free CLP on mechanism.
- Always make sure ratchet mechanism is in the locked position when securing loads.



Installation Instructions

Scout Trailer Kit

Part#87400

WWW.SMITTYBILT.COM

Draw Bar BOM
List

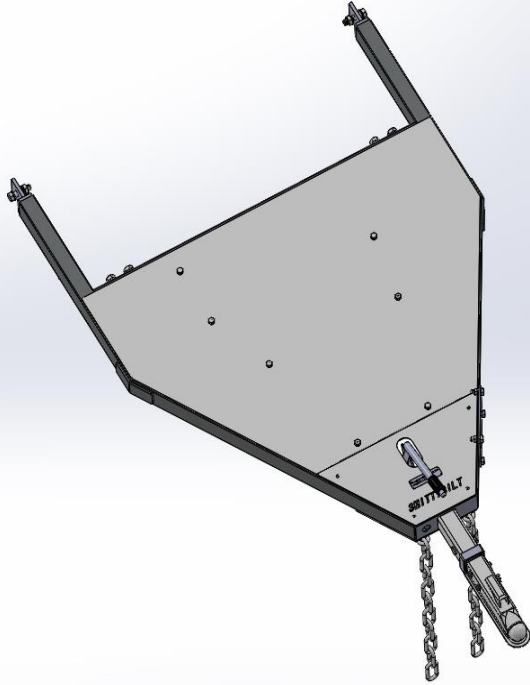

Component	Name	Qty	Secondary Component	Name	Qty
Work piece	Draw bar	1			
	Tire rack base plate	1			
	Hand brake plate	1	Hardware	M5*10 bolt	4
				M5 flat washer	8
				M5 lock washer	4
				M5 nut	4
	Receiver hitch tube	1	Hardware	Pin φ15*75	1
				Washer φ15	1
				Cotter pin φ3	1
Standard Component	M16*45 hexagon head bolt	2			
	M16*110 hexagon head bolt	1			
	M16 Flat washer	6			
	M16 lock washer	3			
	M16 nut	3			
	M14*85 hexagon head bolt	4			
	M14 flat washer	8			
	M14 lock washer	4			
	M14 nut	4			
Accessories	Hand brake	1	Hardware	M12*40 hexagon head bolt	2
				M12 Flat washer	4
				M12 lock washer	2
				M12 nut	2
	Safety chain (920mm)	2	Hardware	D ring	4
	Receiver hitch	1	Hardware	M12*85 hex bolt	2
				M12 flat washer	4
				M12 nut	2
				M12 lock washer	
				M12X20 bolt	1
	Jackey wheel	1	Hardware	M12*35 hexagon head bolt	4
				M12 Flat washer	8
				M12 lock washer	4
				M12 nut	4
Clearance Lamp	2	Hardware	M4*16 self-tapping screw	4	

Torque:
M14 bolts:120 ft/lb
M16 bolts:165 ft/lb



Installation Instructions
Scout Trailer Kit
Part#87400

WWW.SMITTYBILT.COM

Cabin&Frame BOM List

Component	Name	Qty	Secondary Component	Name	Qty
Work piece	Cabin body	1			
	Reinforce rib	2	Hardware	M10*20 bolt	6
Accessories	Eyebolt	11			
	Kitchen door seal	2180mm			
	Generator door seal	2180mm			
	back door seal	3580mm			
	M12*20 Jack bracket bolt	2			
	M12*20 bolt	1			
	60mm tube bolt	1			

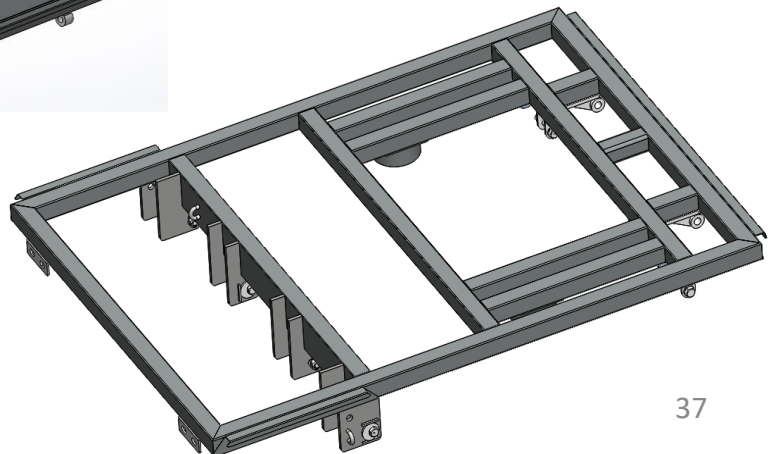
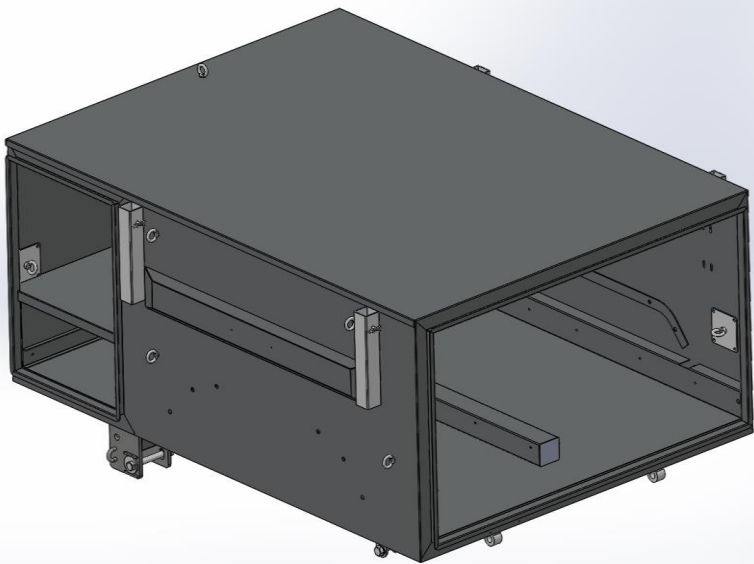



WWW.SMITTYBILT.COM

Installation Instructions

Scout Trailer Kit

Part#87400

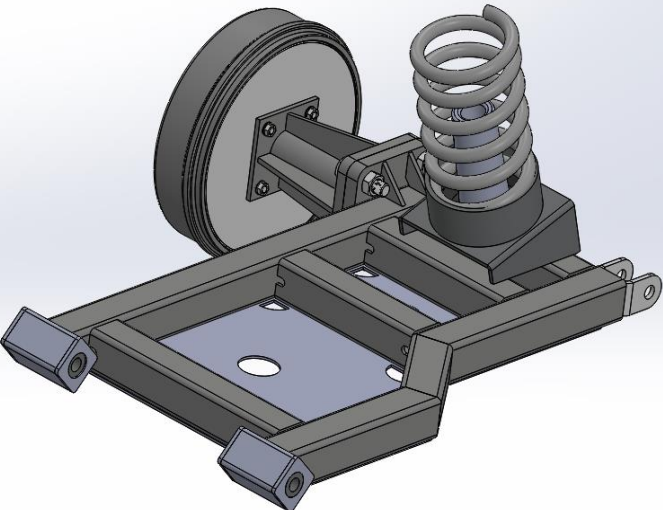

Left Suspension System BOM List

Component	Name	Qty	Secondary Component	Name	Qty
Work piece	Trailing arm-left	1	Hardware	M6*140 bolt	2
				M16flat washer	2
				M16 lock washer	2
				M16 nut	2
Accessories	coil spring	1			
	coil seat	2			
	Bump stop	1	Hardware	M10*30 bolts	1
	Bushing	4			
	Liner pipe	2			
	Shock	2	Hardware	M16*80 bolt	4
				M16 flat washer	8
				M16 lock washer	4
				M16 nut	4
	Limit strap	1	Hardware	M10*90 bolt	2
				M10 washer	4
				M10 nut	2
	Brake system	1	Hardware	M10 lock washer	2
				M16*60 bolt	4
				M16 flat washer	8
				M16 lock washer	4
			M16 nut	4	

Right Suspension System BOM List

Component	Name	Qty	Secondary Component	Name	Qty
Work piece	Trailing arm-right	1	Hardware	M6*140 bolt	2
				M16flat washer	2
				M16 lock washer	2
				M16 nut	2
Accessories	coil spring	1			
	coil seat	2			
	Bump stop	1	Hardware	M10*30 bolts	1
	Bushing	4			
	Liner pipe	2			
	Shock	2	Hardware	M16*80 bolt	4
				M16 flat washer	8
				M16 lock washer	4
				M16 nut	4
	Limit strap	1	Hardware	M10*90 bolt	2
				M10 washer	4
				M10 nut	2
	Brake system	1	Hardware	M10 lock washer	2
				M16*60 bolt	4
				M16 flat washer	8
				M16 lock washer	4
			M16 nut	4	



WWW.SMITTYBILT.COM

Installation Instructions
Scout Trailer Kit
Part#87400

Kitchen Door BOM List

Component	Name	Qty	Secondary Component	Name	Qty
Work piece	Left Door	1			
Accessories	T-lock	1	Hardware	M5*16 stainless steel bolt	4
				M5 flat washer	4
				M5 lock washer	4
				M5 nut	4
	Door Bump Stop	2			
	Hinge	2	Hardware	M6*16 cross recessed countersunk head screw	6
				M6*20 cross recessed countersunk head screw	2
				M6 flat washer	8
				m6 lock washer	8
				M10 nut	8

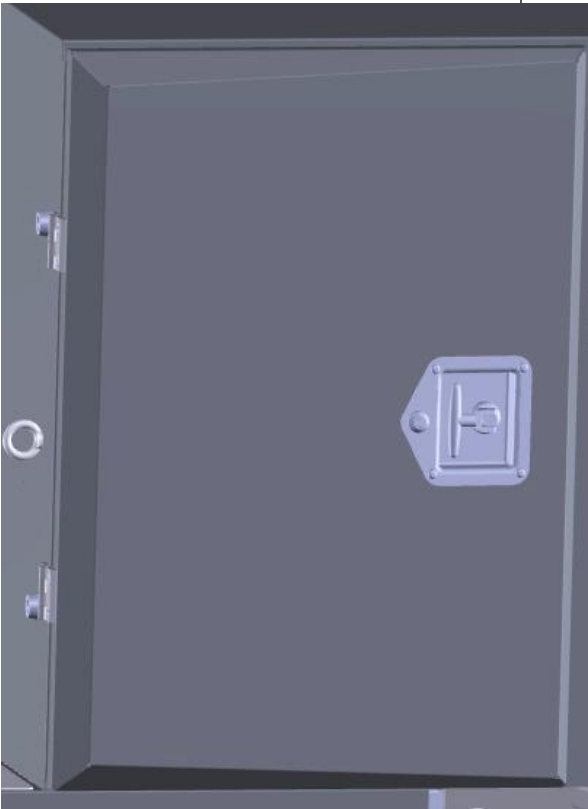



WWW.SMITTYBILT.COM

Installation Instructions
Scout Trailer Kit
Part#87400

Generator Door BOM List

Component	Name	Qty	Secondary Component	Name	Qty
Work piece	Generator Door	1			
Accessories	T-lock	1	Hardware	M5*16 stainless steel bolt	4
				M5 flat washer	4
				M5 lock washer	4
				M5 nut	4
	Door Bump Stop	2			
	Hinge	2	Hardware	M6*16 cross recessed countersunk head screw	6
				M6*20 cross recessed countersunk head screw	2
				M6 flat washer	8
				m6 lock washer	8
					M6 nut





WWW.SMITTYBILT.COM

Installation Instructions
Scout Trailer Kit
Part#87400

Kitchen Drawer BOM List					
Component	Name	Qty	Secondary Component	Name	Qty
Work piece	Kitchen drawer	1			
	Drawer leg-1	1	Hardware	M8*50 bolt	2
				M8 nut	2
				M8 flat washer	4
				M8 lock washer	2
Drawer leg-2	2	Hardware	Wing bolt M8*16	2	
Drawer leg-3	2	Hardware	Wing bolt M8*16	2	
Accessories	1000mm slider(without self-lock)	2	Hardware	M5*16 stainless steel bolt	14
				φ5 stainless steel flat washer	4
				φ5 stainless steel lock washer	4
				M5 stainless steel nut	4
	T-lock	1	Hardware	M5*16 stainless steel bolt	4
				φ5 stainless steel flat washer	4
				φ5 stainless steel lock washer	4
				M5 stainless steel nut	4
	Leg Latch	1	Hardware	M3*6 stainless steel bolt	4





WWW.SMITTYBILT.COM

Installation Instructions
Scout Trailer Kit
Part#87400



Generator Drawer BOM List

Component	Name	Qty	Secondary Component	Name	Qty
Work piece	Generator drawer	1			
	Drawer leg top	1	Hardware	M8*50 bolt	2
				M8 nut	2
				M8 flat washer	4
M8 lock washer				2	
Drawer leg bottom	1	Hardware	Wing bolt M8*16	2	
Accessories	1000mm slider (without self-lock)	2	Hardware	M5*16 cross recessed countersunk head screw	14
				φ5 flat washer	4
				φ5 lock washer	4
				M5 nut	4
	Handle	1	Hardware	M4*6 stainless steel bolt	2
				φ4 stainless steel flat washer	2
				φ4 stainless steel lock washer	2
	Latch	1	Hardware	M5*16 stainless steel bolt	4
				φ5 stainless steel flat washer	4
				φ5 stainless steel lock washer	4
M5 stainless steel nut				4	
drawer leg latch	1	Hardware	M3*6 stainless steel bolt	4	
Loop	4	Hardware	M5*8 rivet	4	



Installation Instructions
Scout Trailer Kit
Part#87400

WWW.SMITTYBILT.COM

Back Drawer BOM list

Component	Name	Qty	Secondary Component	Name	Qty	
Work piece	Back drawer (Negative)	1				
Accessories	1000 mm slider (right side with self-lock, left side without self-lock)	2	Hardware	M5*16 stainless steel bolt	18	
				φ5 stainless steel flat washer	8	
				φ5 stainless steel lock washer	8	
				M5 stainless steel nut	8	
	Handle	1	Hardware	M4*6 stainless steel bolt	2	
				φ4 stainless steel flat washer	2	
				φ4 stainless steel lock washer	2	
	Latch	1	Hardware	M5*16 stainless steel bolt	4	
				φ5 stainless steel flat washer	4	
				φ5 stainless steel lock washer	4	
				M5 stainless steel nut	4	
	Loop		6	Hardware	M5*8 rivet	6





WWW.SMITTYBILT.COM

Installation Instructions
Scout Trailer Kit
Part#87400

Awning Mounting BOM List

Component	Name	Qty	Secondary Component	Name	Qty
Work Piece	Awning rack-1	2	Hardware	Pin ϕ 10*55	2
				cotter pin ϕ 3	2
	Awning rack-2	2	Hardware	Pin ϕ 10*45	2
				cotter pin ϕ 3	2
Accessories	Knob	4			

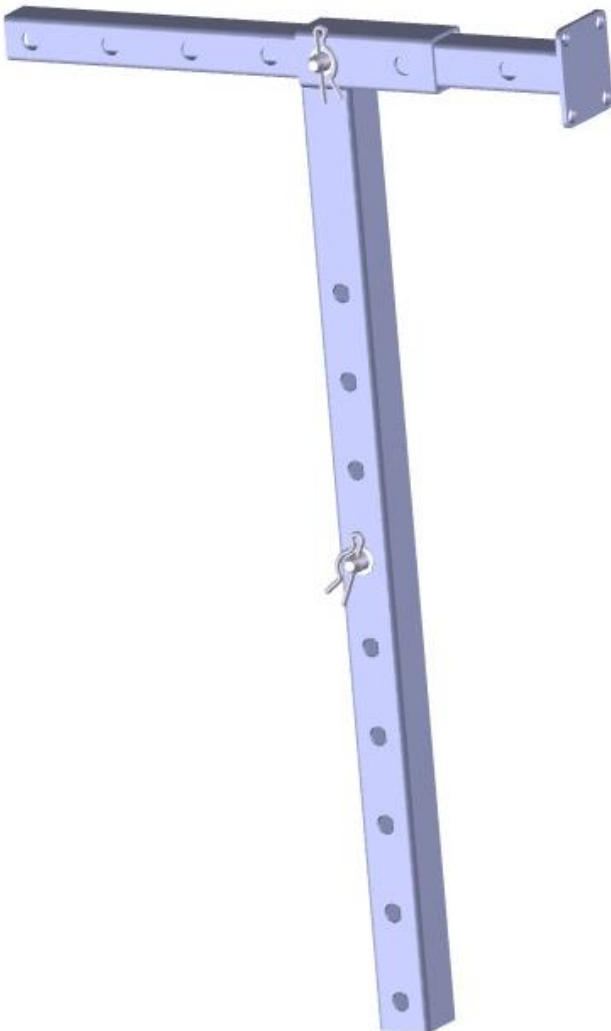



Installation Instructions
Scout Trailer Kit
Part#87400

WWW.SMITTYBILT.COM

Tent Rack BOM List

Component	Name	Qty	Secondary Component	Name	Qty
Work piece	Rack-1	2	Hardware	φ10*65 Pin	4
				φ10 flat washer	4
				cotter pin φ3	4
	U Rack	4			
Accessories	M10 Knob	4			
	φ10*55 Pin	4			
	cotter pin φ3	4			
	φ10 Washer	4			

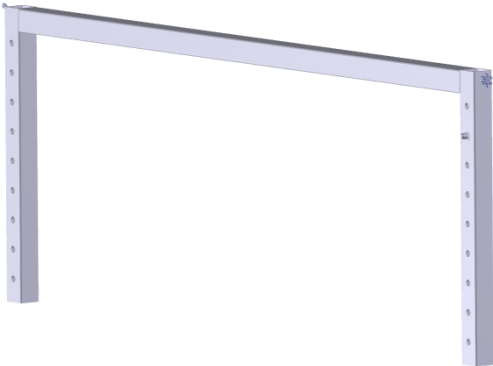

U-rack for tent mounting

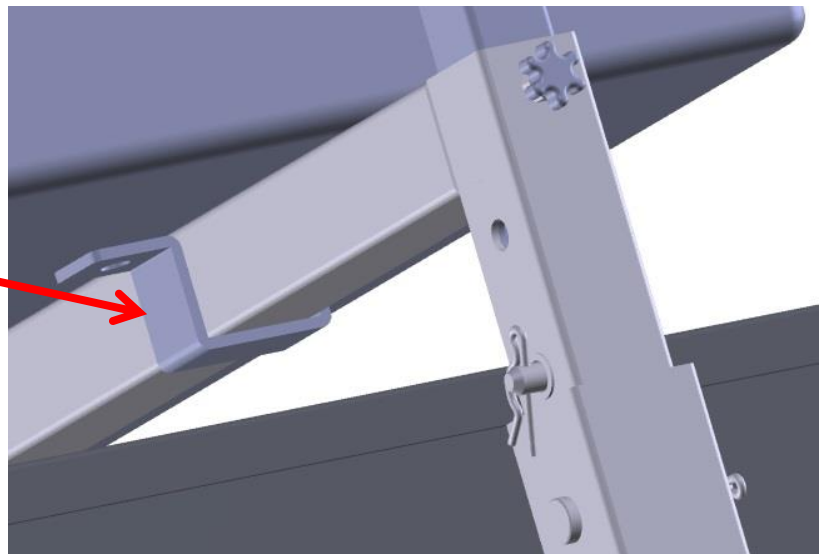



WWW.SMITTYBILT.COM

Installation Instructions
Scout Trailer Kit
Part#87400

Left Fender BOM List					
Component	Name	Qty	Secondary Component	Name	Qty
Work piece	left fender	1	Hardware	M10*25 hexagon head bolt	6
				M10 Flat washer	12
				M10 lock washer	6
				M10 nut	6
Work piece	Tail light bracket	1	Hardware	M6*16 bolt	4
				M6 flat washer	8
				M6 lock washer	4
				M6 nut	4
Accessories	Tail light	1	Hardware	M6 nut	2
				M6 flat washer	2

Right Fender BOM List					
Component	Name	Qty	Secondary Component	Name	Qty
Work piece	Right fender	1	Hardware	M10*25 hexagon head bolt	6
				M10 Flat washer	12
				M10 lock washer	6
				M10 nut	6
Work piece	Tail light bracket	1	Hardware	M6*16 bolt	4
				M6 flat washer	8
				M6 lock washer	4
				M6 nut	4
Accessories	Tail light	1	Hardware	M6 nut	2
				M6 flat washer	2

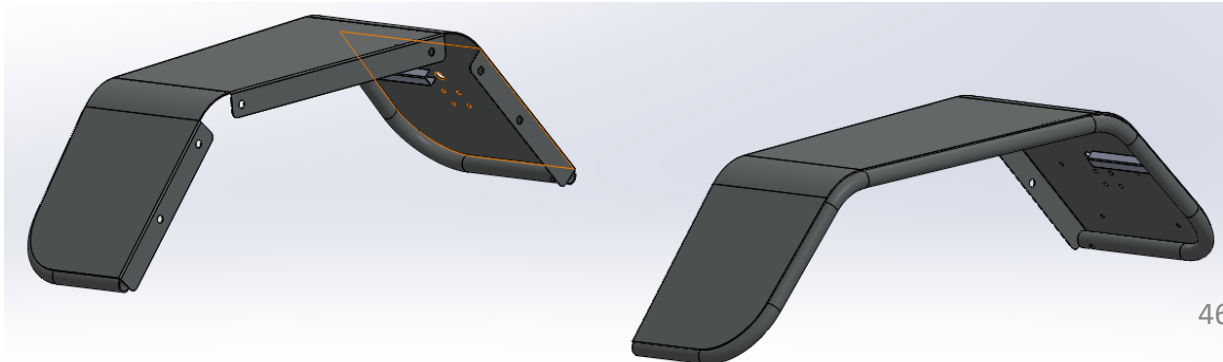



WWW.SMITTYBILT.COM

Installation Instructions
Scout Trailer Kit
Part#87400

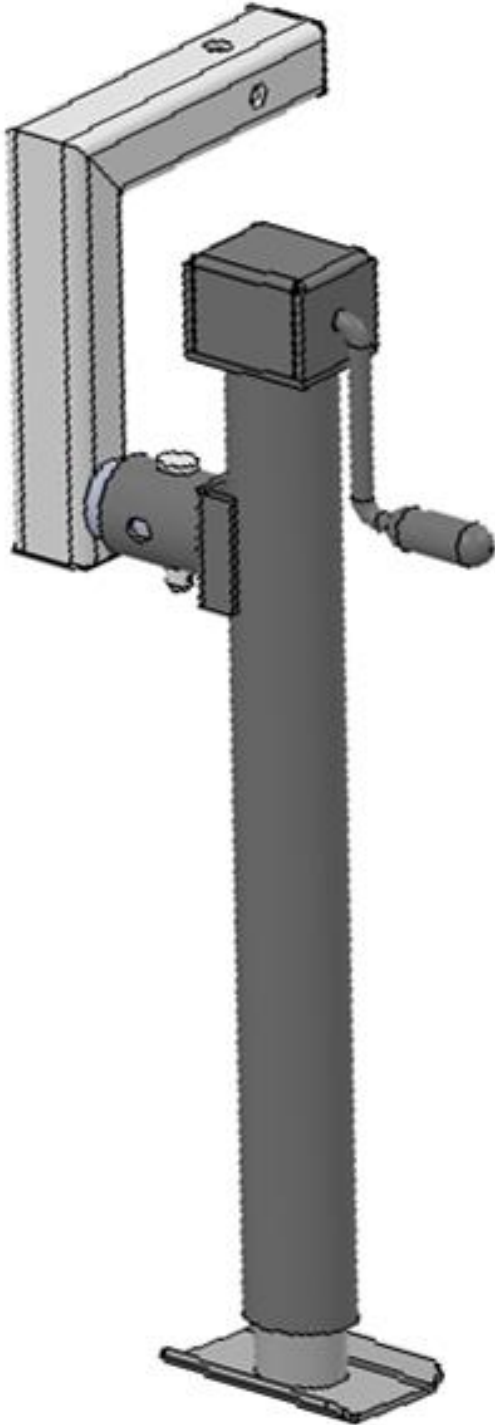

Left Jack BOM List (shown)

Component	Name	Qty	Secondary Component	Name	Qty
Work piece	Jack bracket	1	Hardware	φ12*65 Pin	1
				φ12 Flat washer	1
				Cotter pin φ3	1
Accessories	Jack	1	Hardware	φ12*65 Pin	1
		1		φ12 Flat washer	1
		1		Cotter pin φ3	1

Right Jack BOM List

Component	Name	Qty	Secondary Component	Name	Qty
Work piece	Jack bracket	1	Hardware	φ12*65 Pin	1
				φ12 Flat washer	1
				Cotter pin φ3	1
Accessories	Jack	1	Hardware	φ12*65 Pin	1
		1		φ12 Flat washer	1
		1		Cotter pin φ3	1



Installation Instructions
Scout Trailer Kit
Part#87400

WWW.SMITTYBILT.COM

Wiring harness BOM List

Component	Name	Length	Color
Work piece	light wiring (left)	4650mm	Brown
	Light wiring(right)	5800mm	Brown
	Brake light wiring (left)	4650mm	Red
	Brake light wiring(right)	5800mm	Red
	Clearance Lamp wiring (left)	2100mm	Brown
	Clearance Lamp wiring(right)	2650mm	Brown
	Brake wiring (left)	4150mm	Blue
	Brake wiring(right)	5300mm	Blue
	Ground wiring	35100mm	White
Accessories	2 hole plug	4 sets	
	4 hole plug	2 sets	
	7 hole plug	1	





WWW.SMITYBILT.COM

Installation Instructions
Scout Trailer Kit
Part#87400

Some states/ provinces may require the trailer parts kit be registered with the local DMV. Some states/ provinces may consider that this trailer parts kit is a specially constructed or a homemade vehicle for registration, licensing and/or titling purposes.

When licensing your trailer, you may need a purchase invoice, cash register receipt, MCO, or bill of sale showing the purchase and retail sales tax or use tax collection by the retailer. Keep all receipts for all parts used to build your trailer, they may be needed for titling/registration. Take these to your local Department of Motor Vehicles and upon payment of the appropriate State fees, you will be issued a title, registration and/or license plate. Some states/provinces will require inspection of the assembled and finished trailer parts kit before issuing a title/registration/license. Additional items may be needed depending on state/province regulations, it is the customers responsibility to obtain these parts for their homebuilt trailer.

If you require additional information or guidance on licensing, registration, or titling, please consult your State/Province Department of Motor Vehicles.



WWW.SMITYBILT.COM

Installation Instructions
Scout Trailer Kit
Part#87400

How to Register your Smittybilt SCOUT Trailer Kit

1. Finish assembly of your new Smittybilt SCOUT Trailer Kit.

See instruction manual.

2. Remove tent or awning, if necessary.

Remove or do not install a tent/awning on the SCOUT Trailer Kit prior to taking it to DMV.

3. Visit your local DMV.

4. Register/Title your SCOUT Trailer.

Your local DMV may require:

- Purchase invoice
- Cash register receipt or bill of sale showing the purchase and retail sales tax or use tax collection by the retailer.
- MCO (Manufactures Certificate Of Origin) Some states this will act as your title or pink slip.
- Make sure your receipts cover the trailer kit, tires and wheels, trailer brake controller, and any other parts that were to be used with the construction of the trailer. (Keep all receipts for your records).
- DMV or law enforcement inspection/ verification of trailer.

IMPORTANT:

These instructions are a general guideline. Regulations and requirements will vary by state or province.

Please consult your State/Province Department of Motor Vehicles for additional information or guidance on licensing, registration, or titling.

If you believe that your vehicle has a defect, which could cause a crash or could cause injury or death, you should immediately inform the National Highway Traffic Safety Administration (NHTSA) in addition to notifying Smittybilt.



Installation Instructions

Scout Trailer Kit

Part#87400

WWW.SMITTYBILT.COM

Alignment

Professional alignment is **Required**. Alignment instructions are for a basic setup to allow you to get the trailer to a professional alignment shop. You may also set all cam bolts to the same orientation.

Thrust angles

Choose a point on the front tip of the tongue. Measure from that location to the center of the spindle. (B) Do this for left and right sides. This measurement should be equal.

Set toe

Use a straight edge or other long straight object. Lay it across the tire. Measure from the edge to the frame of the trailer (A) Measurement should be the same on the front and the rear of the tire. Use alignment cam to adjust. Try to get the front about 1/16" less than the rear. This gives a slight toe in and will help track better. Measurements should be taken at the same distance from the tire front and rear.

Camber

Using a camber gauge, set camber to 0°, then recheck toe. Some may set camber at a very low degree to help trailering.

Torque cam bolt nuts to 165 ft. lb.

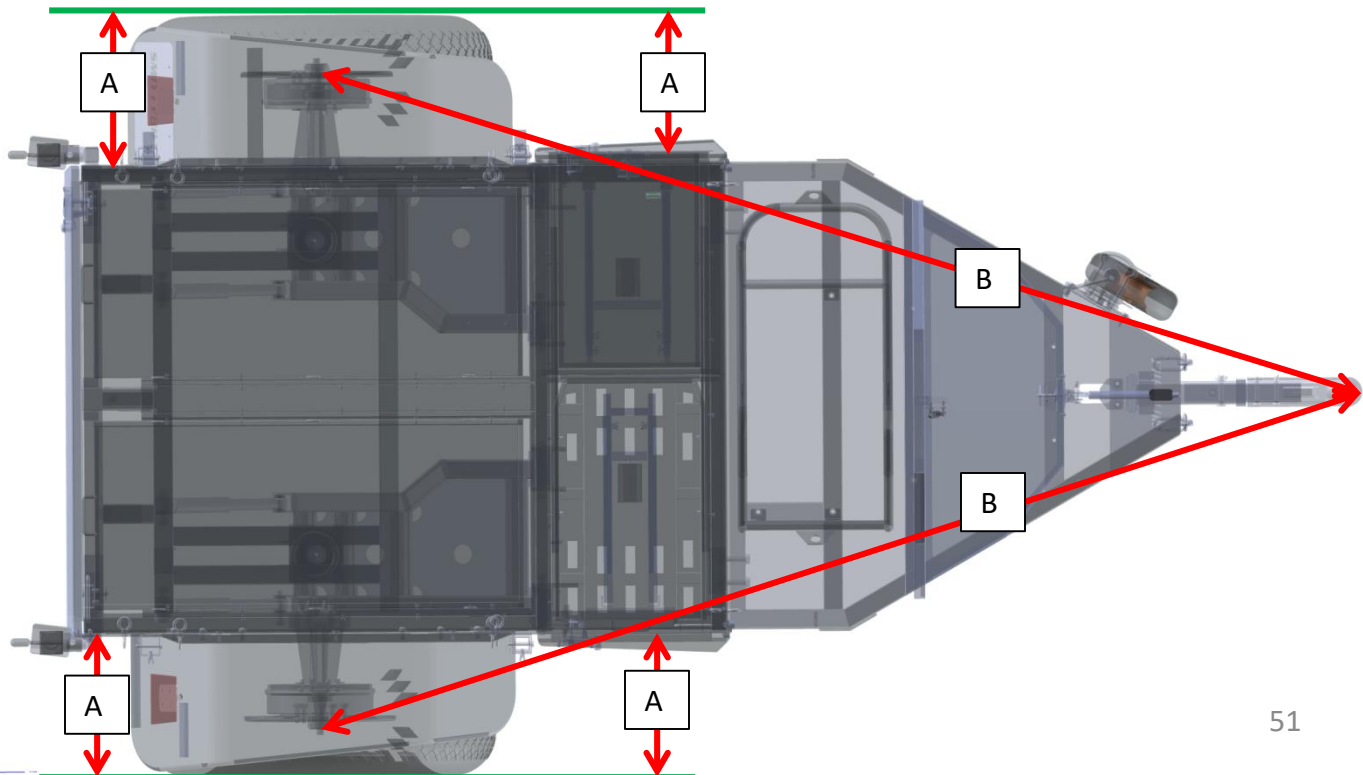



WWW.SMITYBILT.COM

Installation Instructions
Scout Trailer Kit
Part#87400

Wheel Recommendations:

- Wheels should have a center bore of at least 2.55"
- Wheels should have a maximum of 4.25" backspacing but will vary depending on tire and wheel combination. Always check for adequate clearance between tire, trailer body and parking brake cable. If running a 12.5" tire you will want around 4" backspace.
- Factory Wrangler JK wheels will not fit unless you use a lug centric wheel spacer that is at least 1.5"-2" thick. 2" recommended if larger/wider than stock tires are used, to allow clearance between tire and brake line.
- Always use the correct lug nut for your particular wheels. Check with wheel manufacture for lug nut recommendation.

Accessories: (Available separately)

- Prodigy P3 proportional brake controller Part#90195. This has been the best one we have tested and has the most functions and lock out feature for the trailer brakes.
- Worthington Propane Tanks 4.25 and 11lb and holder. (9.1" diameter) BKT-2286 *
- Comp-air tank(S/B2747) and comp-air tank mount (S/B2749*)
- Smittybilt Overlander tent (S/B2783 std size, S/B2883 XL tent)
- Smittybilt Awning (S/B2784 6.5'x6.5' or S/B2787 8.2'x6.5')
- Smittybilt EPS Generator S/B2786
- Smittybilt Arctic Freezer/Fridge S/B2789
- Smittybilt Universal Gerry Can Holder S/B2798*
- Smittybilt Trail Bag S/B2826
- Smittybilt RUT Utility Tool S/B2728
- Smittybilt 54" Trail Jack S/B2722
- Smittybilt Ratchet Straps S/B18602

*Additional mounting holes may need to be drilled, additional hardware may need to be purchased from hardware store.



WWW.SMITYBILT.COM

Installation Instructions
Scout Trailer Kit
Part#87400

Warranty

Tires are not covered by Smittybilt warranty. Contact Procomp Tires (800-776-0767) or other tire manufacture for warranty information. Tires used on trailers do not carry a mileage warranty but will typically carry the manufactures defect warranty.

Limited Warranties

Smittybilt's products are covered under the following limited warranties only. Note that the duration of the limited warranty differs according to the material and finish of the product purchased. Subject to the duration and conditions of the limited warranty stated below, Smittybilt warrants to the original retail purchaser that its products are free from defects in material and workmanship. All other warranties and representations express or implied, are hereby disclaimed, including fitness for merchantability and buyer's intended use or purpose. All parts are sold "AS IS" except for the limited warranties granted herein. Buyer assumes all risks as to the selection, suitability and performance of all goods and products selected. This limited warranty does not cover damage or impairment in any part due to misuse, improper installation, accident or contact with on-road or off-road hazards, product modification, improper or inadequate cleaning and/or maintenance. Smittybilt is not responsible for items damaged during shipping. This warranty is not transferable from the original buyer. For the original Buyer to be eligible for the limited warranty coverage, the Buyer must provide proof of purchase. Due to the intended use, this items carries NO finish warranty.

Customer's remedy hereunder shall be limited only to repair or replacement (at Smittybilt's option) of any defective part(s) returned to Smittybilt at customer's expense. The determination of whether or not a returned part is defective or subject to coverage under the limited warranties stated herein shall be made at Smittybilt's sole discretion.

To assure product quality, Smittybilt reserves the right to change product design, material, specification and finishes without prior notice to customers. This limited warranty gives you specific legal rights and you may also have other rights, which may vary from state to state. Some states do not allow limitations on how long an implied warranty lasts, so the above limitations may not apply as to you. Also, some states do not allow the exclusion or limitation of incidental or consequential damages, so the above limitations or exclusions may not apply to you. Smittybilt reserves the right to discontinue product lines and substitute products, or provide other remedies than those listed in this limited warranty for those discontinued products.



WWW.SMITTYBILT.COM

Installation Instructions
Scout Trailer Kit
Part#87400

Bolt Torque and ID

Decimal System

Metric System

All Torques in Ft. Lbs.

Bolt Size	Grade 5	Grade 8	Bolt Size	Class 9.8	Class 10.9	Class 12.9
5/16	15	20	M6	5	9	12
3/8	30	45	M8	18	23	27
7/16	45	60	M10	32	45	50
1/2	65	90	M12	55	75	90
9/16	95	130	M14	85	120	145
5/8	135	175	M16	130	165	210
3/4	185	280	M18	170	240	290

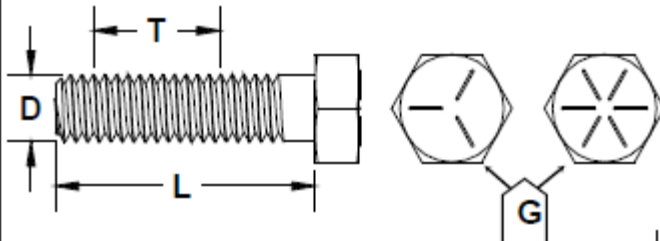

1/2-13x1.75 HHCS **Grade 5** **Grade 8**
 (No. of Marks + 2)

D T L X

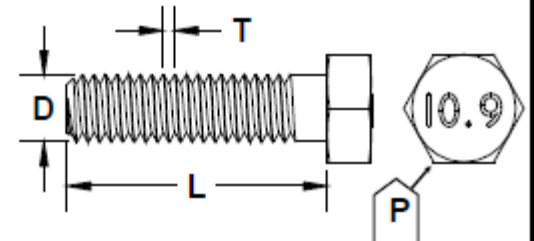

M12-1.25x50 HHCS

D T L X

G = Grade (Bolt Strength)
 D = Nominal Diameter (Inches)
 T = Thread Count (Threads per Inch)
 L = Length (Inches)
 X = Description (Hex Head Cap Screw)

P = Property Class (Bolt Strength)
 D = Nominal Diameter (Millimeters)
 T = Thread Pitch (Thread Width, mm)
 L = Length (Millimeters)
 X = Description (Hex Head Cap Screw)