

Installation Instructions



Angular Drop Steps Part #: S/BEXT25-TX 2025+ Toyota 4Runner®



For Technical Support / Warranty Information please call 1-800-776-0767
Smittybilt, 1017 W 600 N, STE 4, Ogden, UT 84404

Introduction

Thank you for choosing Smittybilt accessories for your Toyota 4Runner®. If you would like to view our full range of available accessories, please visit us at www.smittybilt.com

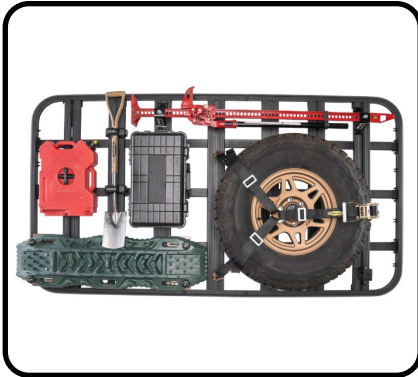

Defender Platform Rack



Dual Zone Fridge/Freezers



Recovery Gear and Winches

Toyota® and 4Runner® are registered trademarks of Toyota Motor Corporation®

Important Notes Before Starting

! IMPORTANT NOTE

Carefully read through this entire instruction manual thoroughly before attempting to install this part.

! WARNING

Serious injury can occur when working on vehicles alone.

When possible, work with another person to reduce risk of injury from strain or other dangers that can occur when working alone.

! WARNING

The weight limit for these steps is 445lbs. Do not exceed this weight limit.

Exceeding this weight limit can cause damage or personal injury.

The following tools will be required to complete the installation of this part:

TOOLS REQUIRED

3/8" Drive Ratchet

13mm Socket

Tape Measure



For Technical Support / Warranty Information please call 1-800-776-0767
Smittybilt, 1017 W 600 N, STE 4, Ogden, UT 84404

Box Contents & Product Safety

EXT25-TX Box Contents

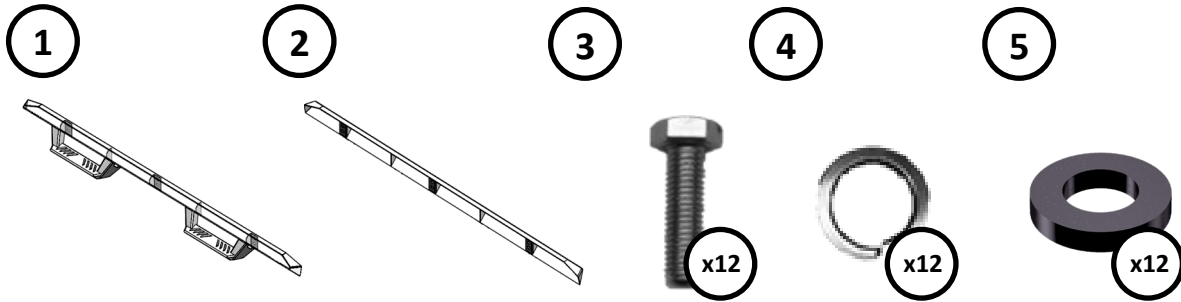

ID	Part Description	QTY
1	Driver Side Angular Drop Step	1
2	Passenger Angular Drop Step	1
3	M8-1.25x30mm Hex Head Bolt	12
4	M8 Split Lock Washer	12
5	M8 Flat Washer	12

Installation Instructions: Toyota 4Runner® Angular Drop Steps



Step 1:

If your 4Runner® currently has running boards, remove them prior to proceeding. Remove steps and hardware from the box. Confirm you have all the components needed for installation. Then, remove the **Angular Drop Step** from the packaging and measure the distance between the first set of mounting brackets.



For Technical Support / Warranty Information please call 1-800-776-0767
Smittybilt, 1017 W 600 N, STE 4, Ogden, UT 84404

Installation Instructions: Toyota 4Runner® Angular Drop Steps



Step 2:

Underneath your 4Runner®, clean the mounting surfaces using some rubbing alcohol and a cloth. Find the first set of mounting holes and confirm the distance is the same as measured in **Step 1**.

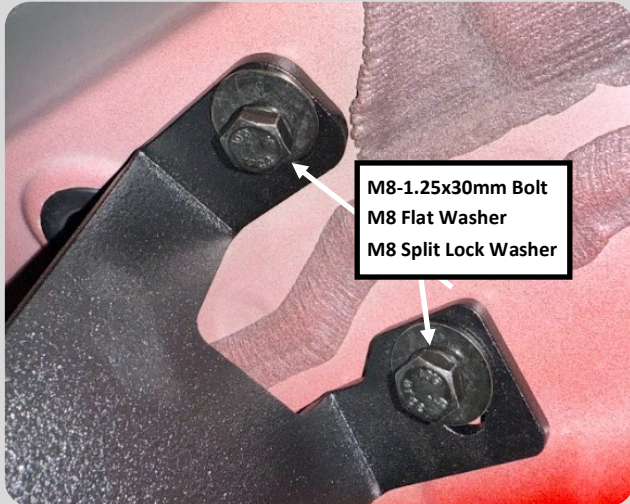

Step 3:

With the assistance of a second person, lift the step up into place and align the **(3)** welded mounting brackets to the OE holes on the frame of your truck. Loosely secure the brackets to the vehicle using **(6) M8-1.25x30mm Bolts**, **(6) M8 Split Lock Washers** and **(6) M8 Flat Washers**. Do not torque the hardware yet.



Step 4:

Confirm you are happy with the fitment and placement of the step. Then torque all hardware to spec using the guide on **Page 6**.



For Technical Support / Warranty Information please call 1-800-776-0767
Smittybilt, 1017 W 600 N, STE 4, Ogden, UT 84404

Installation Instructions: Toyota 4Runner® Angular Drop Steps



Step 5:

Repeat Steps 1-4 for the **Passenger Side Angular Drop Step**.



Step 6:

Installation is now complete.



For Technical Support / Warranty Information please call 1-800-776-0767
Smittybilt, 1017 W 600 N, STE 4, Ogden, UT 84404

Bolt Torque Specifications

Use this only as a guide for hardware without a called out torque specification in the instruction manual.

Bolt Torque and ID						
Decimal System			Metric System			
<i>All Torques in Ft. Lbs. Maximums</i>						
Bolt Size	Grade 5	Grade 8	Bolt Size	Class 9.8	Class 10.9	Class 12.9
5/16	15	20	M6	5	9	12
3/8	30	45	M8	18	23	27
7/16	45	60	M10	32	45	50
1/2	65	90	M12	55	75	90
9/16	95	130	M14	85	120	145
5/8	135	175	M16	130	165	210
3/4	185	280	M18	170	240	290

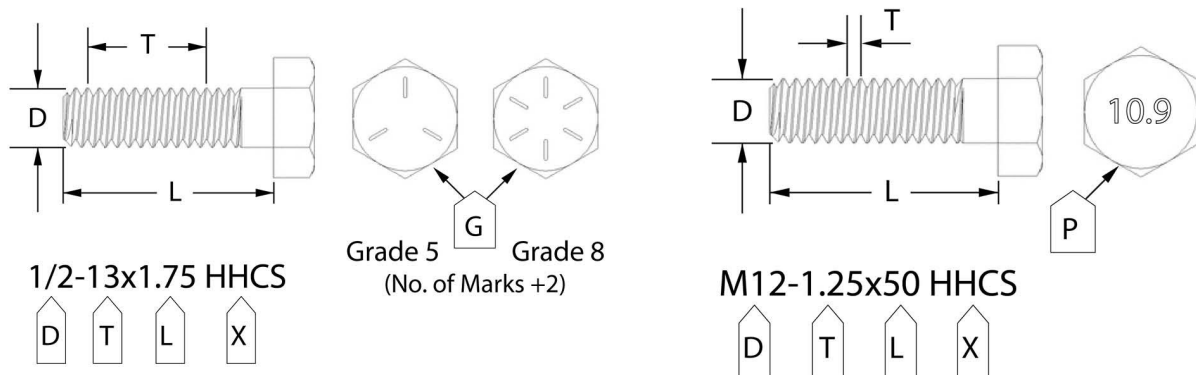

G= Grade (Bolt Strength)
 D= Nominal Diameter (Inches)
 T= Thread Count (Threads per Inch)
 L= Length (Inches)
 X= Description (Hex Head Cap Screw)

P= Property Class (Bolt Strength)
 D= Nominal Diameter (Millimeters)
 T= Thread Pitch (Thread Width, mm)
 L= Length (Millimeters)
 X= Description (Hex Head Cap Screw)



For Technical Support / Warranty Information please call 1-800-776-0767
 Smittybilt, 1017 W 600 N, STE 4, Ogden, UT 84404

Notes and Disclaimers

Product cleaning and maintenance instructions

Stainless Steel Finish – Aluminum polish may be used to polish small scratches and scuffs on the finish. Mild soap, window or glass cleaner may be used to clean the finish.

Dual state powder coat finish – Mild soap, window or glass cleaner may be used to clean the finish. In order to protect the finish, you may wax your product on a regular basis with pure carnauba automotive wax. Do not use any types of soap, polish or wax that contains abrasive that could damage the finish. Textured coated finishes should be cleaned with a mild soap on a damp sponge. Do not apply polish or wax that requires to be removed by means of buffing. This type of wax is commonly used at car wash facilities.

Chrome Finish – Mild soap, window or glass cleaner may be used to clean the finish. In order to protect the finish, you should wax your product on a regular basis with pure carnauba automotive wax. Do not use any types of soap, polish or wax that contains abrasive that could damage the finish.

Maintenance: Retorque hardware after 500 miles and periodically thereafter.

SMITTYBILT ADVANTAGE WARRANTY

LIMITED-LIFETIME WARRANTY FOR STRUCTURAL COMPONENTS

5-YEAR FINISH WARRANTY

Smittybilt Automotive Products, LLC (SAP) warrants to the original purchaser that (a) the physical components (e.g., metal components, welds, etc.) of any SAP **Angular Drop Steps** will be free of defects in material and workmanship for the lifetime of the product from the date of purchase of the Steps, and (b) the finish will be free of defects in material and workmanship for a period of 5-years from the original date of purchase. This warranty applies only to the original purchaser of the steps and is non-transferable. To obtain any warranty service, you must provide SAP with a proof of purchase and date of purchase that is acceptable to SAP, such as a copy of your purchase receipt.

This warranty does not cover labor of part replacement of the steps. SAP will, at its sole discretion, provide replacement part(s) for a defective step or component, provided this is done within the warranty period. To request assistance under warranty, one must call or email using the phone number or email at the bottom of this page. This warranty does not apply (1) wearable components; or (2) if the step(s) has/have been damaged, including, but not limited to: abuse, misuse, collision, modification, misapplication, improper installation, or improper service. This warranty is void if any SAP serial number has been removed or defaced; or if the steps are used for any commercial, industrial, or rental applications. This warranty only applies to steps bought, sold, and used within the United States or Canada unless otherwise specifically agreed in writing by SAP.

THE WARRANTY SET FORTH ABOVE IS THE ONLY WARRANTY. THERE ARE NO OTHER WARRANTIES, EXPRESSED OR IMPLIED, INCLUDING BUT NOT LIMITED TO IMPLIED WARRANTIES OF MERCHANTABILITY OR FITNESS FOR A PARTICULAR PURPOSE. ANY IMPLIED WARRANTY WHICH BY LAW MAY NOT BE EXCLUDED IS LIMITED TO A DURATION OF ONE (1) YEAR FROM THE DATE OF ORIGINAL RETAIL PURCHASE OF THE PRODUCT. No SAP dealer, agent, or employee is authorized to make any modification, extension or addition to this warranty. SAP SHALL NOT BE LIABLE FOR SPECIAL, INDIRECT, INCIDENTAL OR CONSEQUENTIAL DAMAGES (INCLUDING, BUT NOT LIMITED TO, LOST PROFITS, DOWN TIME OR LOSS OF USE) UNDER ANY LEGAL THEORY, EVEN IF SAP WAS ADVISED OF THE POSSIBILITY OF SUCH DAMAGES. Some states do not allow the exclusion of implied warranties or the exclusion or limitation of liability for incidental or consequential damages, or limitations on how long an implied warranty lasts, so the above limitation or exclusion may not apply to you. This Warranty gives you specific legal rights. You may also have other rights that vary from state to state. SAP reserves the right to change product design without notice. In situations in which SAP has changed a product design, SAP shall have no obligation to upgrade or otherwise modify previously manufactured products. For warranty inquiries contact SAP at:

Smittybilt Automotive Products, LLC

Customer Service Department

Call 1-800-776-0767 or Email info@smittybilt.com



For Technical Support / Warranty Information please call 1-800-776-0767
Smittybilt, 1017 W 600 N, STE 4, Ogden, UT 84404